



OPERATOR'S MANUAL

OPERATOR'S MANUAL

EW160E SN 322001 - 322999
EW180E SN 322001 - 322999

EW160E, EW180E



English

VOLVO

Volvo Construction Equipment
volvoce.com



⚠ WARNING: Breathing diesel engine exhaust exposes you to chemicals known to the State of California to cause cancer and birth defects or other reproductive harm.

- Always start and operate the engine in a well-ventilated area.
- If in an enclosed area, vent the exhaust to the outside.
- Do not modify or tamper with the exhaust system.
- Do not idle the engine except as necessary.

For more information go to www.P65warnings.ca.gov/diesel.

⚠ ADVERTENCIA: Respirar los gases del escape de motores a diésel le expone a químicos conocidos por el Estado de California como causantes de cáncer y defectos de nacimiento u otros daños reproductivos.

- Siempre encienda y opere el motor en un área bien ventilada.
- Si es en un área cerrada, ventile el orificio del escape hacia el exterior.
- No modifique ni altere el sistema de escape.
- No encienda el motor, excepto cuando sea necesario.

Para mayor información visite www.P65warnings.ca.gov/diesel.

⚠ WARNING: Operating, servicing and maintaining a passenger vehicle or off-road vehicle can expose you to chemicals including engine exhaust, carbon monoxide, phthalates, and lead, which are known to the State of California to cause cancer and birth defects or other reproductive harm. To minimize exposure, avoid breathing exhaust, do not idle the engine except as necessary, service your vehicle in a well-ventilated area and wear gloves or wash your hands frequently when servicing your vehicle. For more information go to www.P65Warnings.ca.gov/passenger-vehicle.

⚠ ADVERTENCIA: Operar, dar servicio y mantenimiento a un vehículo de pasajeros o vehículo todo terreno puede exponerle a químicos incluyendo gases del escape, monóxido de carbono, ftalatos y plomo, los cuales son conocidos por el Estado de California como causantes de cáncer y defectos de nacimiento u otros daños reproductivos. Para minimizar la exposición, evite respirar los gases del escape, no encienda el motor excepto si es necesario, dé servicio a su vehículo en un área bien ventilada y utilice guantes o lave sus manos frecuentemente cuando dé servicio a su vehículo. Para mayor información visite www.P65Warnings.ca.gov/passenger-vehicle.



EW160E/EW180E

Foreword

This operator's manual is intended as a guide for the correct use and maintenance of the machine. Read this manual carefully before you start and move the machine or before you carry out any preventive maintenance.

Keep this manual in the lockable storage compartment so that it is always available for easy reference. Replace it immediately if it is lost.

The operator's manual describes the applications for which the machine was primarily designed. It has been written to be valid on all markets. Therefore, please ignore any sections which do not relate to your machine or to the work that you do with your machine.

NOTE!

If the manual covers more than one machine, the information relates to all machines unless otherwise specified.

When designing this machine, much time has been invested in achieving the best possible efficiency and safety. But accidents do happen, and most of them can be attributed to human error. A safety-conscious person and a well-maintained machine make up a reliable, powerful, and profitable combination. **Therefore, read the safety instructions and follow them.**

We constantly strive to develop and improve the efficiency of our products by making changes to their design. We reserve the right to make design modifications to the products even after they have been delivered. Also, we reserve the right to change data and equipment, as well as the service and maintenance instructions, without prior notice.

OPERATOR'S MANUAL

Table of contents

Presentation

Instrument panels

Other controls

Operating instructions

Operating techniques

 Safety when servicing

Maintenance

Specifications

Alphabetical index



Foreword

2

Safety regulations

The machine operator is responsible for being aware of and complying with the relevant, legally prescribed, national and regional safety instructions. The safety instructions in this operator's manual are applicable only in cases where no legislated safety instructions are in force.

DANGER

The safety symbol combined with this signal word indicates a hazardous situation which, if not avoided, ***will result in death or serious injury***. Danger is limited to the most extreme situations.

WARNING

The safety symbol combined with this signal word indicates a hazardous situation which, if not avoided, could result in ***death or serious injury***.

CAUTION

The safety symbol combined with this signal word indicates a hazardous situation which, if not avoided, could result in ***moderate or minor injury***.

NOTICE

Indicates a potentially hazardous situation which may result in machine damage.

NOTE!

Used in order to refer to installation, operating, or maintenance information which is important but not danger-related.

Get to know the capacity and limits of your machine!



Table of contents

Foreword	1
Identification numbers	6
Presentation	7
Machine view	12
CE-marking, EMC-directive	13
Communication equipment, installation	16
Safety components	17
Product plates	18
Information and warning decals	19
USA federal clean air act	29
Instrument panels	33
Instrument panel, left	34
Instrument panel, front	40
Display unit	47
Instrument panel, right	80
Instrument panel, rear	90
Other controls	91
Controls	91
Cab	104
Control lockout system	110
Operator comfort	111
Operating instructions	140
Safety rules when operating	146
Measures before operating	152
Starting engine	153
Hydraulic system, warming up	157
Operating	158
Steering	160
Braking	163
Exhaust aftertreatment system	165
Stopping	176
Parking	177
Retrieving and towing	179
Attachments, alternative lowering	183
Transporting machine	186
Operating techniques	191
Eco driving	192
Whole-body vibrations	193
Rules for digging	195
Boom Suspension System (BSS)	197
Working within dangerous areas	199
Attachments	207
Attachments, connecting and disconnecting	210
Pressure release	221
Buckets	222
Offset boom	227
Hammer	228
Lifting objects	230
Equipment towing	234
Signalling diagram	243



Table of contents

Safety when servicing	246
Service position	247
Before service, read	249
Entering, leaving and climbing the machine	255
Fire prevention	257
Handling hazardous materials	259
Handling line, tubes and hoses	263
Maintenance	264
Lubrication and service chart	268
Maintenance service, every 10 hours	273
Maintenance service, every 50 hours	275
Maintenance service, every 100 hours	283
Maintenance service, every 250 hours	287
Maintenance service, every 500 hours	295
Maintenance service, every 1000 hours	300
Maintenance service, every 2000 hours	301
Maintenance service, when required	302
Specifications	327
Recommended lubricants	327
Fuel system	332
Service capacities and change intervals	338
Engine	339
Electrical system	340
Wheels	344
Cab	348
Noise and vibrations	349
Hydraulic system	350
Machine weights	352
Dimensions	353
Working ranges	359
Recommended bucket sizes	365
Digging forces	372
Lifting capacities	373
Service history	406
Alphabetical index	409





6

Identification numbers

Identification numbers

Make a note below of the identification numbers of the machine and its components. Always state the number when contacting the manufacturer and when ordering spare parts.

<p>Manufacturer:</p>	<p>Volvo Construction Equipment Germany GmbH D-54329 Konz-Könen Germany</p>
<p>Machine PIN (Serial number)</p>	
<p>Axles</p>	
<p>Travel gearbox</p>	

Presentation

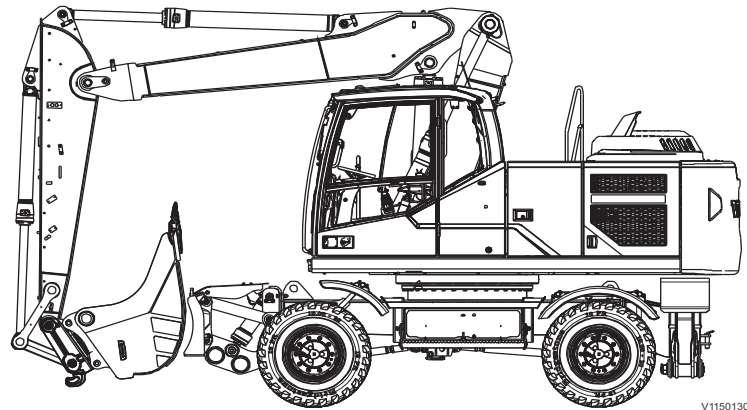

Intended use

The machine is intended to be used under normal conditions for the applications described in this manual. If it is used for other purposes or in potentially dangerous environments, for example explosive atmosphere, flammable environment or areas with dust containing asbestos and so on, special safety regulations must be followed and the machine be equipped for such use. Contact the manufacturer / dealer for further information.

Environmental requirements

Be aware of the environment when operating and during service and maintenance of the machine. Always follow local and national environmental legislation applicable to all handling of the machine.

Engine

D6J is a four stroke, straight, six-cylinder, turbocharged, direct injected diesel engine with charge air cooling.

In order to reduce nitrogen oxides, particles, hydrocarbons and carbon monoxide, the engine includes external, cooled exhaust gas recirculation (EGR) and an exhaust aftertreatment system (EATS) with AdBlue®/DEF injection.

The exhaust aftertreatment system is a certified spark arrestor in accordance with Directive 97/68/EC and EN 1834.

AdBlue®/DEF information

AdBlue®/DEF is needed for the reduction of nitrogen oxides (NO_x). AdBlue®/DEF is filled in a separate tank on the machine that is completely separate from the fuel tank. AdBlue®/DEF must not be mixed into the diesel tank and diesel must not be mixed into the AdBlue®/DEF.

For distribution of AdBlue®/DEF (only valid for US market):

- Volvo CE Customer Support: 1-877-823-1111 (business hours)
- www.volvoce.com (outside of business hours)



For distribution of AdBlue®/DEF (all other markets), please contact your local Volvo dealer for more information.

See page 302 for information about filling AdBlue®/DEF.

Exhaust aftertreatment system

The engine features an exhaust aftertreatment system (EATS) consisting of two mufflers. The first one contains a diesel oxidation catalyst (DOC) and a diesel particulate filter (DPF) to reduce emissions of particulate matter (PM). The second one contains a selective catalytic reduction catalyst (SCR) to reduce nitrogen oxide (NOx) emissions. AdBlue®/DEF is injected into the exhausts in order to reduce NOx.

The DPF traps particles from the engine exhausts and, since it is continuously loaded with these particles from the exhausts, it needs to be regenerated in order to burn off the particles. A passive regeneration process is constantly oxidizing the soot particles stored in the DPF.

To achieve the defined emission values the EATS is electronically controlled and monitored by the aftertreatment control module (ACM).

For more information, see page 165.

Electrical system

The machine is equipped with the Volvo CEA2+ (Common Electronic Architecture 2+) electrical system, a computerized monitoring and control system.

The different control units are communicating via bus systems.

Relays and fuses

The relays and fuses are grouped in the electrical distribution box in the cab behind the driver seat under the cover.

Brake system

The brake system is a dual-circuit system with two accumulators, operated via the servo hydraulics.

In order to ensure the function of the brakes, even at loss of pressure supply, the system is equipped with two accumulators. Herewith, at least eight times activation of the brakes is possible after the loss of servo pressure.

Service brakes

The service brakes are servo-hydraulically operated, self-adjusting, wet multi-disc brakes in two separate brake circuits.

Digging brake

The service brake pedal is also used as digging brake.

Parking brake

The parking brake is a negative action wet disc brake integrated in the travel gearbox. It is spring applied and pressure released.

Steering system

The machine is provided with a hydrostatic steering system.

As an optional equipment the machine can feature a Comfort Drive Control (CDC) function for control lever steering.



Cab

The cab is supported on hydraulic dampening mounts to reduce shock and vibration levels. A sound absorbing lining provides low noise levels. The upper windscreen can be pushed up into the roof. The cab has a sliding window pane in the cab door. The cab is provided with air filter, recirculation and heating systems. The cab is also prepared for the installation of FOPS/FOG (optional equipment).

For more information about the hydraulic elevating cab, see page 108.

The cab is designed to ensure minimum crash protection space according to ROPS standard for excavator (ISO12117-2), see page 104.

If any part of the cab's protective structure is affected by permanent deformation or rupture, the cab shall be immediately replaced.

Never carry out any unauthorised alterations to the cab, e.g. lowering the roof height, drilling, welding on brackets for fire extinguisher, radio aerial or other equipment, without first, through a dealer, having discussed the alteration with personnel at the Volvo Engineering Department. This department will decide whether the alteration may cause the approval to become void.

It is important that all parties concerned are aware of these regulations.

Hydraulic system

The machine has a load independent flow sharing hydraulic system which always ensures that each movement receives oil according to the demand and no function stops.

The diesel engine drives the machine's working pump, which gives a hydraulic flow to the working hydraulics and the travel motor.

The double gear pump is mounted behind the working pump and supplies the servo, brake and steering hydraulics.

Equipment

Depending on the requirements of different markets, the machine may be provided with different types of optional equipment.

Examples of optional equipment: Comfort Drive Control (CDC), Volvo Dig Assist, trailer towing solution (TTS), boom suspension system (BSS), tiltrotator control system, different types of attachment brackets, deluxe operator seat, additional working lights, sun blind, mudguards and much more. Please contact Volvo distributors for further information about optional equipment.

Modifications

Modifications of this machine and its components such as engine- and auxiliary system, including the use of unauthorized attachments, accessories, units, or parts, may affect the machine's integrity (condition), the machine's ability to function in the way for which it is designed and voids the EU type-approval of the machine and engine- and auxiliary system. Persons or organizations performing unauthorized modifications assume all responsibility for consequences that arise due to modifications or



can be attributed to modifications, including damages to the machine.

No modifications of any kind may be performed on this product unless each specific modification first has been approved in writing by Volvo Construction Equipment. Volvo Construction Equipment reserves the right to reject all warranty claims that have arisen due to or can be traced to unauthorized modifications.

Unauthorised modifications on the upperframe can have an influence on the ROPS protection system which is intended to secure the driver in case of an accident.

Modifications may be considered to be officially approved, if at least one of the following conditions has been met:

- 1 The attachment, the accessory, the unit, or the part has been manufactured or distributed by Volvo Construction Equipment and has been installed according to the factory-approved method described in a publication available from Volvo Construction Equipment; or
- 2 The modification has been approved in writing by the Engineering Department for the relevant product line at Volvo Construction Equipment.

Swing drive unit

EW160E:

The swing movement of the machine is performed by a directacting motor with integrated swing brake.

EW180E:

The swing movement of the machine is performed by a motor with gearbox to reduce the speed and increase the torque.

Logged machine data

The machine is equipped with a software system, which records various information about the machine and this information is transferred from the machine to Volvo and used by Volvo and its authorized workshops in the product development process and for possible malfunction detection.

Questions regarding this information can be directed to your dealer.

CareTrack

The machine may be equipped with CareTrack, a telematics system developed by Volvo Construction Equipment. The system stores machine data, e.g., machine position, operating hours, fuel consumption, fuel level, that can be sent by wireless transmission to a computer. CareTrack is available in different versions, depending on the required information level.

CareTrack makes it easier to plan for service and reduces costly downtime. Productivity is improved by knowing if machines are being operated correctly and how much fuel is being consumed. CareTrack also allows the customer to restrict the operating area of the machine, by using virtual fences. This helps to eliminate unauthorized machine use and theft. For further information, contact a Volvo Construction Equipment dealer.

The CareTrack system transmits data, in the same way a mobile phone does, with a maximum output rate of 10 W. The transmitter is always on and the operator cannot switch it off.

Local precautions and restrictions applicable to mobile phones, for example safety distance, also apply to the CareTrack system.

Tool kit

(optional equipment)

The machine can be equipped with different toolbox options:

- standard toolbox
(either on left hand side or on both sides)
- drawer type toolbox
(on left hand side, right hand side or both sides)

Toolbox content

A daily maintenance kit is an optional equipment which contains the following tools:

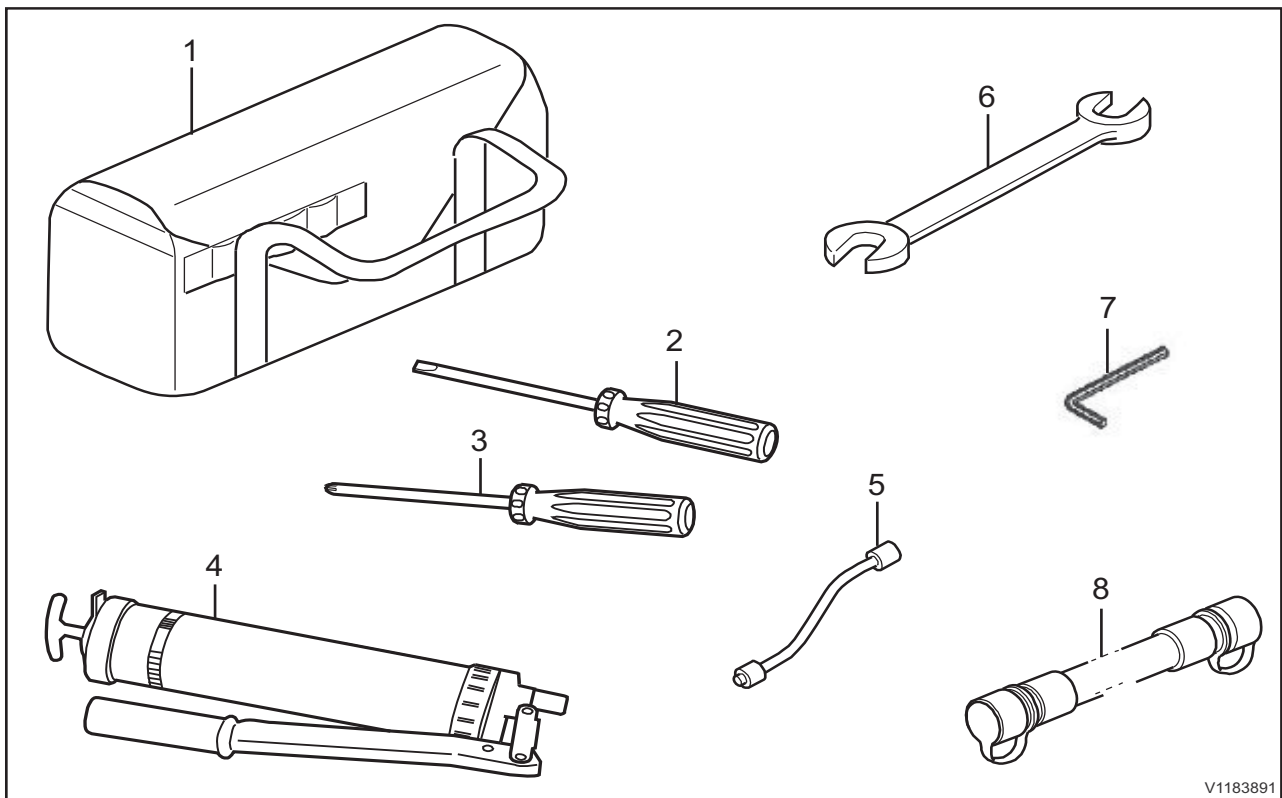

V1183891

- Tool bag for daily maintenance kit (1)
- Screwdrivers (2 and 3)
- Grease gun with extension (4 and 5)
- 8 open-end wrenches in different sizes (6)
- Allen wrench (7)
- Drain hose (8) (standard equipment)
- Wheel chocks (optional equipment)

12 Presentation
Machine view

Machine view

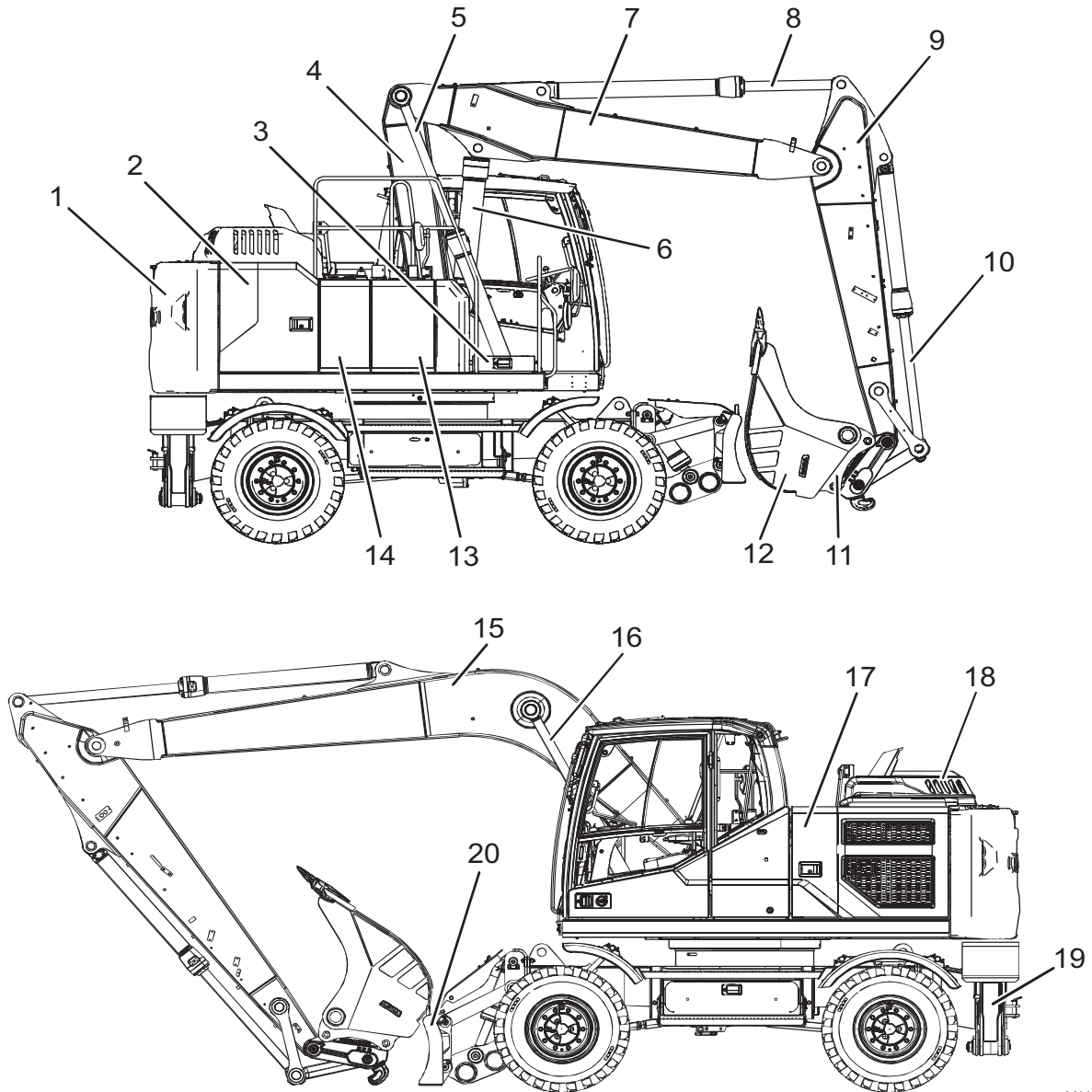

V1148082

1	Counterweight	11	Attachment bracket (quickfit)
2	Side cover	12	Bucket
3	Front cover	13	Fuel Tank
4	First boom on two-piece boom	14	Hydraulic oil tank
5	Boom cylinders	15	Boom on mono-block boom
6	Two-piece boom cylinder	16	Boom cylinder on mono-block boom
7	Second boom on two-piece boom	17	Side cover
8	Dipper arm cylinder	18	Engine cover
9	Dipper arm	19	Stabiliser legs
10	Bucket cylinder	20	Stabiliser blade



V1067840

CE-marking, EMC-directive

CE marking

(Declaration of Conformity : Only applies to machines marketed within the EU/EEA.)

This machine is CE marked. This means that when delivered the machine meets the applicable "Essential Health and Safety Requirements", which are given in the EU Machinery Safety Directive, 2006/42/EC.

Any person carrying out changes that affect the safety of the machine, is also responsible for the same.

As proof that the requirements are met, the machine is supplied with an EU Declaration of Conformity, issued by Volvo CE for each separate machine. This EU declaration also covers attachments manufactured by Volvo CE. The documentation is a valuable document, which should be kept safe and retained for at least ten years. The document should always accompany the machine when it is sold.

If the machine is used for other purposes or with other attachments than described in this manual, safety must at all times and in each separate case be maintained. The person carrying out such action is also responsible for the action which, in some cases, may require a new CE marking and the issue of a new EU Declaration of Conformity.



EU EMC Directive

The electronic equipment of the machine may in some cases cause interference to other electronic equipment, or suffer from external electromagnetic interference, which may constitute safety risks.

The EU EMC directive about "Electromagnetic compatibility", 2014/30/EU, provides a general description of what demands can be made on the machine out of a safety point of view, where permitted limits have been determined and given according to international standards.

A machine or device which meets the requirements should be CE marked. Our machines have been tested particularly for electromagnetic interference. The CE marking of the machine and the declaration of conformity also cover the EMC directive. If other electronic equipment is fitted to this machine, the equipment must be CE marked and tested on the machine with regard to electromagnetic interference.



EU conformity certificate

We,

Volvo Construction Equipment Germany GmbH
Max-Planck-Straße 1
54329 Konz
Germany
Retention of technical documentation by:
Manager Product Platform Wheeled Excavator

hereby declare that the machine specified below:
Wheeled Excavator

Type	Serial number	Output	Representative sound power level (L _{WA})	Guaranteed sound power level (L _{WA})	Year of CE marking
EW160E		115 kW	99 dB	100 dB	
EW180E		129 kW	100 dB	101 dB	
EW180E Tropical cooling		129 kW	101 dB	102 dB	

is compliant with the following relevant provisions:

- EC Directive "Machinery" 2006/42/EC
- EC Directive "Noise Emissions" 2000/14/EC
- EU Directive "EMC" 2014/30/EU

Significant harmonised standards used in connection with this:

- EN 474-1 and 474-5

The Volvo EW160E/EW180E conforms to directive 2000/14/EC Annex VIII (Full Quality Assurance).

The sound marking is based on issuance of EU Notified Body for noise measurement carried out by Volvo Construction Equipment Germany GmbH.

Notified Body:

DGUV; No: 0515

Test Prüf- und Zertifizierungsstelle

80687 München (Germany)

Konz, <dd.mm.yyyy>

<N. N.>

Manager Product Platform Wheeled Excavator

Volvo Construction Equipment Germany GmbH



Communication equipment, installation

NOTICE

All installation of optional electronic communication equipment must be performed by trained professionals and in accordance with the Volvo Construction Equipment instructions.

Protection against electromagnetic interference

This machine has been tested in accordance with EU directive 2014/30/EC governing electromagnetic interference. It is therefore very important that all non-approved electronic accessories, such as communication equipment, should be tested before installation and use, since they can cause interference to the electronic systems of the machine.

Guidelines

The following guidelines must be followed during installation:

- The antenna placement must be chosen to give good adaptation to the surroundings.
- The antenna cable must be of the coaxial type. Be careful to ensure that the cable is undamaged, that the sheath and braid are not split at the ends, the braid covers the connector ferrules and has good galvanic contact with them.
- The mating surface between the antenna mounting bracket and the bodywork must have clean metal surfaces, with all dirt and oxide removed. Protect the mating surfaces against corrosion after installation to maintain good galvanic contact.
- Remember to separate interfering and interfered cables physically. Interfering cables consist of the communication equipment's supply cables and antenna cable. Interfered cables are those which are connected to electronic devices in the machine. Install the cables as close as possible to earthed (grounded) sheet metal surfaces, since the sheet metal has a shielding effect.



Safety components

Genuine Volvo spare parts guarantee the best service life, reliability, and safety for the machine and operator. If reliable and purpose-built parts are not used, your safety, health, and the machine's function may be compromised. Contact your dealer and state the machine's model designation/serial number (PIN-number) when ordering spare parts. Position of PIN-plate, see section "Product plates".

Your Volvo dealer always has up-to-date spare part information that is updated at regular intervals via the information system PROSIS.

Safety-classified machine and spare parts

Safety-classified machine and spare parts means that the components are intended to fulfil a safety function.

Examples of safety-classified machine parts/spare parts

- Removable protective devices/guards over rotating parts and hot surfaces
- Protective plates, rails, covers, and steps
- Components included in systems to reduce sound and vibrations
- Components included in systems to improve the operator's visibility
- Complete operator's seat incl. seatbelt
- Decals and plates
- Cab filter

NOTE!

Safety-classified machine and spare parts shall be reinstalled, repaired, or replaced immediately if they have been removed or damaged.

When changing machine operator/owner, malfunctions and defects of safety-classified machine and spare parts shall be reported immediately and an action plan shall be established.

There is more important information in this Operator's Manual about the components that are considered safety-classified.



V1148961

Example of PIN number on PIN plate

- A Volvo Construction Equipment
- B Machine type
- C Check letters
- D Serial number

Product plates

When ordering spare parts, and in all telephone enquiries or correspondence the model designation and the Product Identification Number (PIN) must always be quoted.

Product plate

- The product plate on the machine shows the manufacturer's name and address, model designation, PIN, machine weight, engine output and the manufacturing year. The plate is positioned under the boom on the superstructure frame.
- The EPA plate is positioned under the boom on the superstructure frame (North America only).

Engine product plate

- The engine product plate contains type designation and part and serial numbers and is positioned on the engine.

Travel gearbox product plate

- The gearbox product plate contains type designation and part and serial numbers and is positioned on the travel gearbox.

Axle product plate

- The axle product plate contains type designation and part and serial numbers and is positioned on each axle.

Information and warning decals

The operator should know and pay attention to the information and warning plates / decals which are positioned on the machine. All plates/decals are not installed on all machines, as they are market and machine dependent. The decals/plates must be kept free from dirt, so that they can be read and understood. If they have been lost or no longer are legible, they must be replaced immediately. The part number (order number) is given on the respective plates/decals and in the Parts Catalogue.

NOTE!

The word WARNING is given on the warning decals for North America.

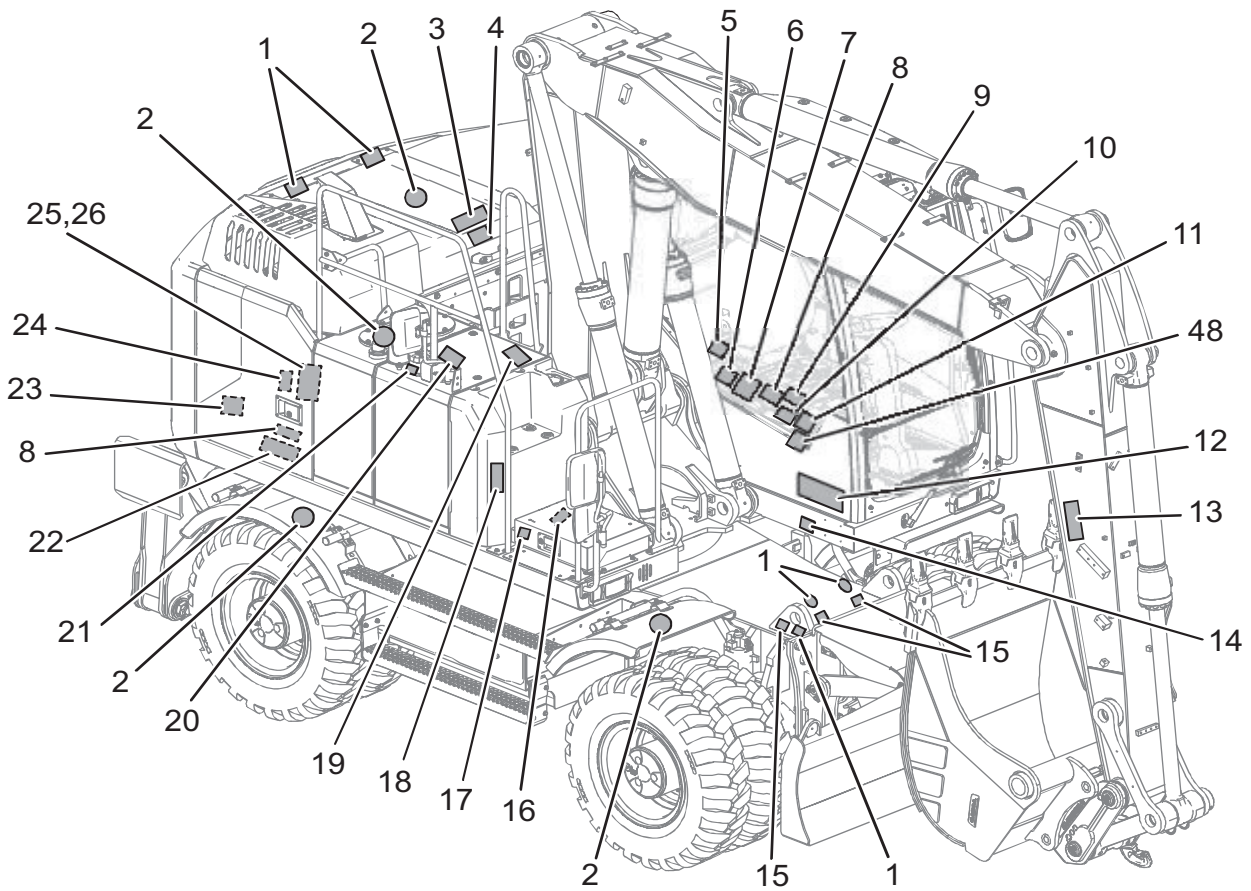

V1189982

Presentation
Information and warning decals

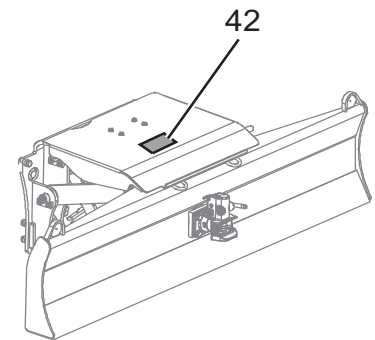
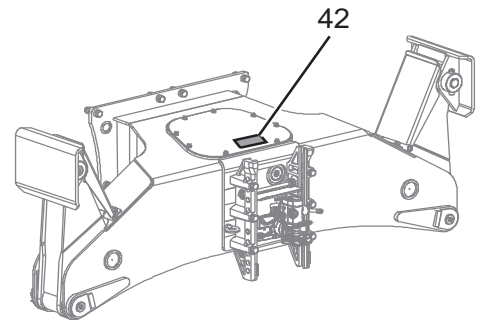
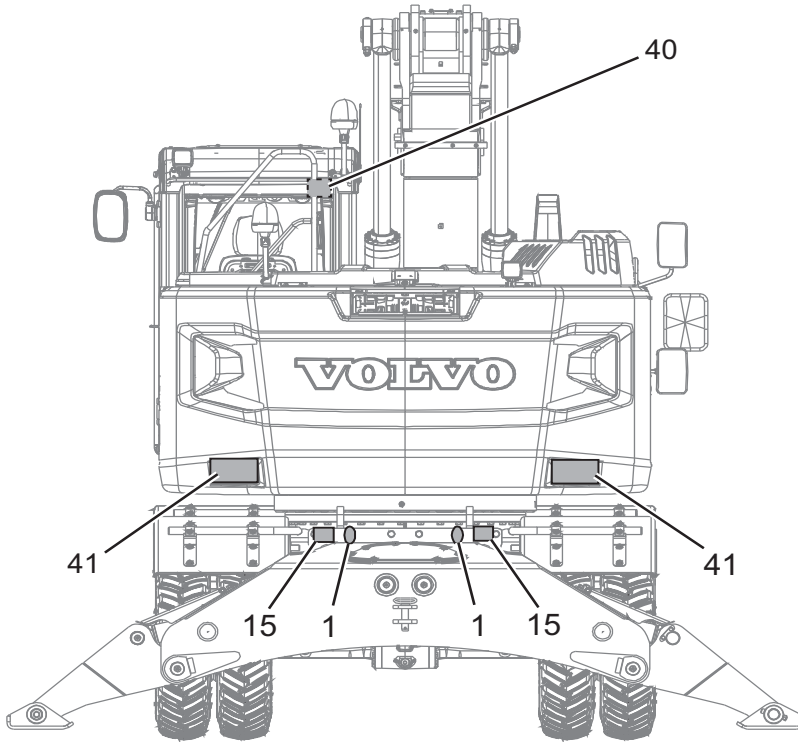

V1189984

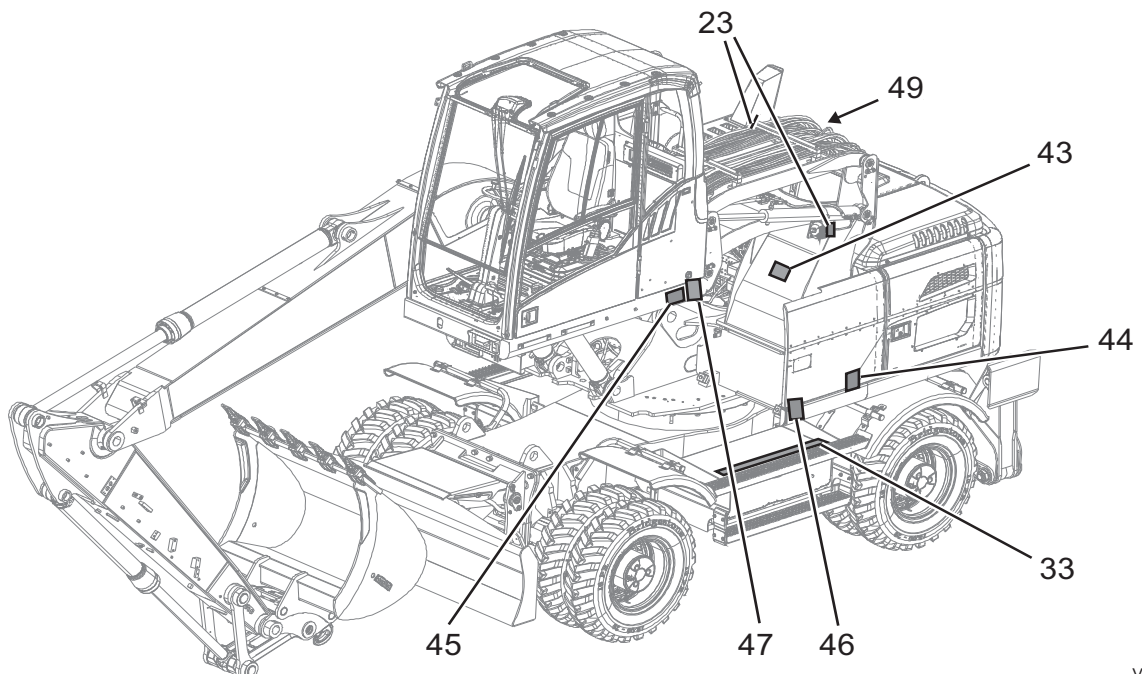

V1187251

Hydraulic elevated cab

22 Presentation
Information and warning decals

<p>V1065364</p> <p>1 Lifting point.</p>	<p>V1065343</p> <p>2 WARNING! Do not step on this surface.</p>
<p>V1108876</p> <p>3 WARNING! Hot surfaces and rotating parts/fan.</p>	<p>V1065366</p> <p>4 Coolant information. See page 331.</p>
<p>V1187459</p> <p>5 Grapple changeover decal (optional equipment)</p>	<p>V1179548</p> <p>6 WARNING! Electric digging brake (optional equipment) — read the Operator's manual.</p>
<p>V1152064</p> <p>7 Lifting capacity, see page 373</p>	<p>V1065340</p> <p>8 WARNING! First read the Operator's manual before operating the machine.</p>

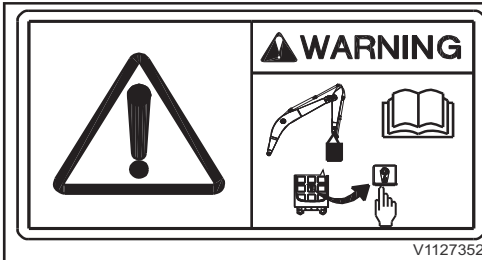

V1127352

9
WARNING! Overload warning must always be engaged when lifting a suspended load.

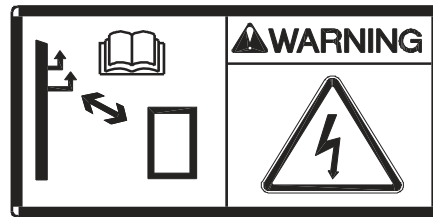

V1108898

10
WARNING! High voltage. Keep sufficient distance from electrical power lines. See page 199.

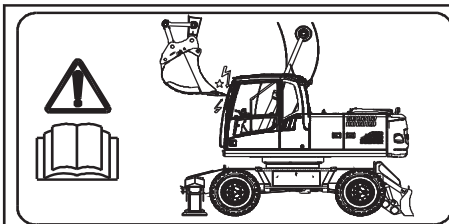

V1108866

11
WARNING! Attachment may strike the cab.

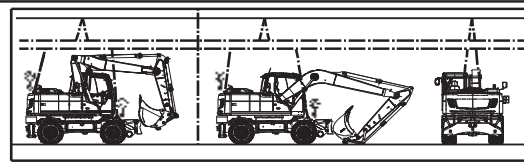

V1108862

12
Lifting instruction



V1065351

13
WARNING! Risk of crushing. Do not stand in the vicinity of a raised load/boom.

Complies/Conformes
CAN ICES-2/NMB-2

xxxxxxx
V1180289

14
EMC compliance decal (only for NA)

24 Presentation
Information and warning decals



V1065381

15
Attaching point for lashing/tying down.



V1152065

16
WARNING! Battery - risk for explosion, corrosive burns and electric shock. (Decal placed below battery cover.)

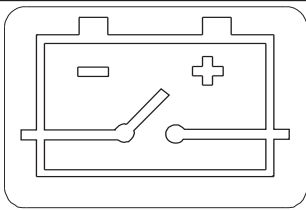

V1065373

17
Battery location.



V1065352

18
WARNING! Risk of slipping or falling.



V1137928

19
AdBlue®/DEF filling, see page 302



V1099517

20
Sulphur content information.
See page 332 (A: for North America, B: for Europe)



V1108886

21
WARNING! Risk of fire. Do not smoke during fuel filling.



V1108880

22
WARNING! Risk of burning. Hot machine parts and surfaces.



V1108882

23
WARNING! Handling accumulator. Risk for explosion. See page 317.

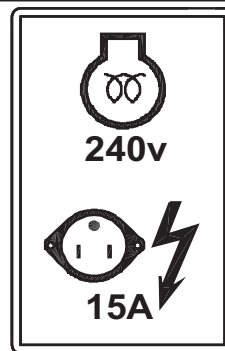

V1152076

24
WARNING! Engine preheater (optional equipment / either with 240V or 120V). See page 154 for more information.

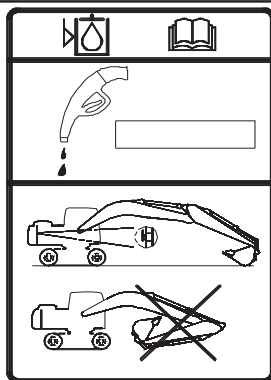

V1065370

25
Machine position when checking hydraulic oil level.



V1161457

26
Type of hydraulic oil filled at factory (example).



V1065344

27
WARNING! Hot coolant under pressure.



V1085556

28
Sound pressure level in cab.

Presentation
Information and warning decals

26

V1180179

29
Refrigerant information decal (example of new version)
See pages 348 and 262 for more information.

V1161456

30
Pressure check points.

V1152070

31
Fuse box layout decal (inside the fuse box)

V1108872

32
Lubrication and service chart.

V1173358

33
WARNING! Risk of squeezing fingers.

V1085554

34
Sound power level outside the machine.

<p>V1137926</p> <p>35 Battery disconnect switch</p>	<p>V1152072</p> <p>36 WARNING! When leaving the machine, move the control lockout lever down to lock the system securely.</p>
<p>V1085557</p> <p>37 Unlock - lock the hydraulic system.</p>	<p>V1152074</p> <p>38 Lever and pedal functions (example).</p>
<p>V1152073</p> <p>39 WARNING! Pattern changer (optional equipment), see page 94.</p>	<p>V1065380</p> <p>40 Emergency exit.</p>
<p>V1108878</p> <p>41 WARNING! Risk of crushing. Do not enter the excavator's working area.</p>	<p>V1187457</p> <p>42 (only with trailer towing option, example) Maximum allowed loads for trailer towing, see page 234.</p>



28 Presentation
Information and warning decals



V1108922

43
(only with Hydraulic elevated cab)
WARNING! Risk of crushing. Do not enter this area.



V1108925

44
(only with Hydraulic elevated cab)
Hydraulic elevated cab decal.



V1187244

45
Hydraulic elevated cab - maximum lifting weight
(only with Hydraulic elevated cab)



46



47

V1152135

(only with Hydraulic elevated cab) Notice!
Hydraulic elevated cab.

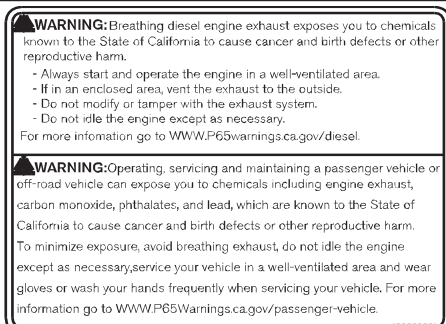

V1197619

48
California Prop 65 decal



V1205601

49
When climbing on the machine a personal fall arrest system (PFAS) or an external access system must be used. It has to be connected to the external climbing fixture underneath this decal. Read also instruction on page 255.



USA federal clean air act

The Federal Clean Air Act under US Code Title 42, Chapter 85, Subchapter II, Part A, Section 7522 (a) (3) (A) & (B) prohibits the removal of or to render inoperative any air pollution control devices or the bypass, defeat or modification of an EPA certified non-road engine to a non-certified configuration. Installed components and systems of the machine and engine may be emissions related and may not be altered. Such systems and components include the exhaust and air intake systems, cooling system, fuel system, computer and electrical systems.

Federal regulations implementing the Clean Air Act for non-road engines, 40 CFR 1068.101 (b) (1) reads in part as follows:

You may not remove or render inoperative any device or element of design installed on or in engines/equipment in compliance with the regulations prior to its sale and delivery to the ultimate purchaser. You also may not knowingly remove or render inoperative any such device or element of design after such sale and delivery to the ultimate purchaser. This includes, for example, operating an engine with the use of incorrect fuel or engine oil that renders the emissions control system inoperative. A civil penalty up to \$3,750 for each day an engine or piece of equipment is operated in violation may be assessed.

Customer Assistance

Volvo Construction Equipment wishes to help assure that the Emission Control System Warranty is properly administered. In the event that you do not receive the warranty service to which you believe you are entitled under the Emission Control System Warranty, we recommend that you should contact the nearest Volvo Construction Equipment regional office for assistance.

**Normal non-road engine use**

The maintenance instructions are based on the assumption that this conventional machine will be used as designated in the operator's instruction manual and operated only with the specified fuel and lubrication oils.

Non-road engine maintenance

Owners are responsible for properly maintaining their engines/ equipment per instructions in the Operator's Manual. This is a non-road engine of conventional design and any local dealer may perform the necessary non-road emission control maintenance as defined in this manual.

Volvo recommends that the purchaser use the service program for the non-road engine, known as preventative maintenance, including the recommended engine emission control maintenance.

In order to document that the proper regular maintenance has been performed on the non-road engine, Volvo recommends that the owner keep all records and receipts of such maintenance. These records or receipts should be transferred to each subsequent purchaser of the non-road engine.

Service performed by your local dealer

Your local dealer is best suited to give you good, dependable service since he has trained service technicians and is equipped with genuine original manufacturer's parts and special tools and the latest technical publications. Discuss your servicing and maintenance requirements with your local dealer. He can tailor a maintenance program for your needs.



For scheduled service or maintenance, it is advisable to contact your local dealer in advance to arrange for an appointment to ensure availability of the correct equipment and service technician to work on your machine. In this way you will assist your local dealer in reducing the time required to do service on your machine.

A repair shop or person of the owner's choosing may maintain, replace, or repair emission-control devices and systems. Volvo recommends that the owner keep all records and receipts of such maintenance.

Preventive maintenance program

In order for the conventional non-road engine to retain the reliability and performance parameters such as noise level and emission levels it had when delivered, it is essential that it receives regularly scheduled service, inspections, adjustments, and maintenance.

Fuels and Lubricants

This engine is designed to operate with fuels and lubricants as specified in the Recommended Lubricants section of this manual. Failure to use specified fuels and lubricants may render the emissions control systems inoperative, operate outside of certified emission limits, permanently damage emission components and reduce service intervals.

Fuel recommendations:

Diesel engines for 2011 and later model years are designed to operate only with Ultra Low Sulphur Diesel (ULSD) fuel with a maximum sulfur content of 15 ppm. Use of fuel other than ULSD will reduce the efficiency and durability of the engine, permanently damage the advanced emission control systems, reduce fuel economy and possibly prevent the engine from running at all. Manufacturer's warranties are likely to be rendered void by usage of improper or incorrect fuel, and usage of fuels other than ULSD fuel in diesel-powered machines is illegal and punishable with civil penalties.



The proper selection of fuel is essential for good economy, performance and engine life. Number 2D ULSD should be used when climatic conditions permit. Number 1D ULSD can be used during cold weather conditions. Blends of Number 1D and Number 2D ULSD fuels can be used to suit various climatic conditions. It's important that the fuel is not contaminated with dust or water which can damage the engines fuel system and increase wear of the engine. Do not use kerosene, JP8 and additives that may contain higher level of sulfur.

In order to avoid excessive sedimentation and to minimize the emissions of sulfur dioxide, the fuel's sulfur content should be as low as possible. Do not use of kerosene, JP8 and additives that may contain higher level of sulfur. The diesel fuels recommended for use shall meet ASTM designation: D 975 no. 1-D (C-B) or no. 2-D (T-T) with a cetane level above 42 and sulfur content not exceeding 15 ppm.

Your machine is equipped with a Diesel Particulate Filter (DPF) and it is mandatory to use diesel fuel with a sulphur content less than 15 ppm.

Lubricant:

Low ash or low SAPS (Sulphated Ash, Phosphorus and Sulphur) engine oil grades are required to avoid DPF clogging. See in chapter specifications.

Instrument panels

Carefully read through this Operator's Manual and keep it in the cab so that it is always available.

NOTE!

Do not operate the machine until you know the function and position of the instruments and operating controls. Always ensure that the seat belt is fastened before starting the machine.

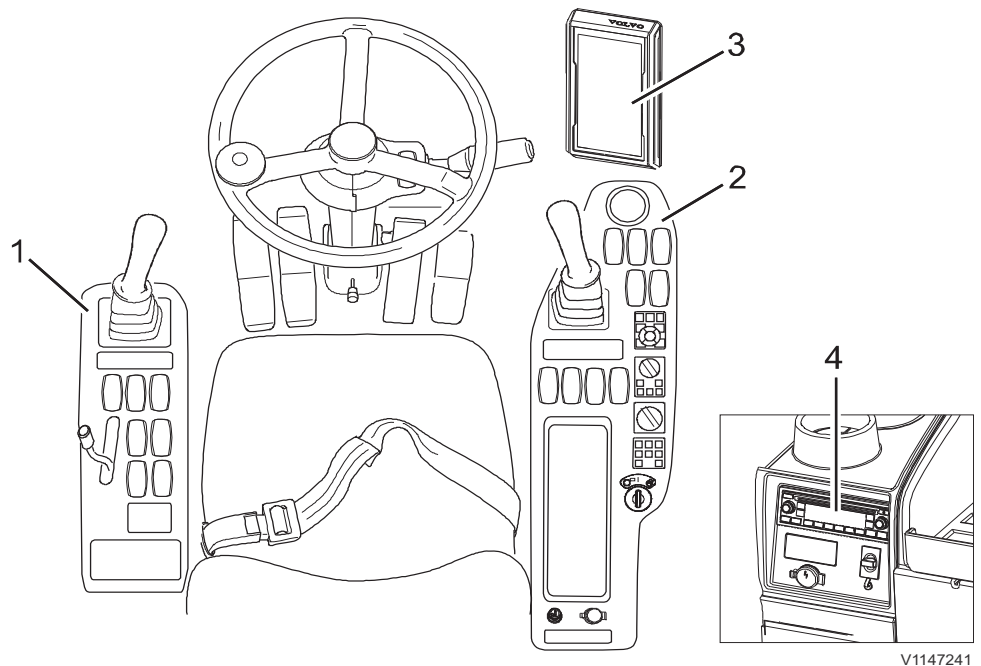

V1147241

1	Instrument panel, left
2	Instrument panel, right
3	Instrument panel, front (Instrument Cluster)
4	Instrument panel, rear

34 Instrument panels
Instrument panel, left

Instrument panel, left

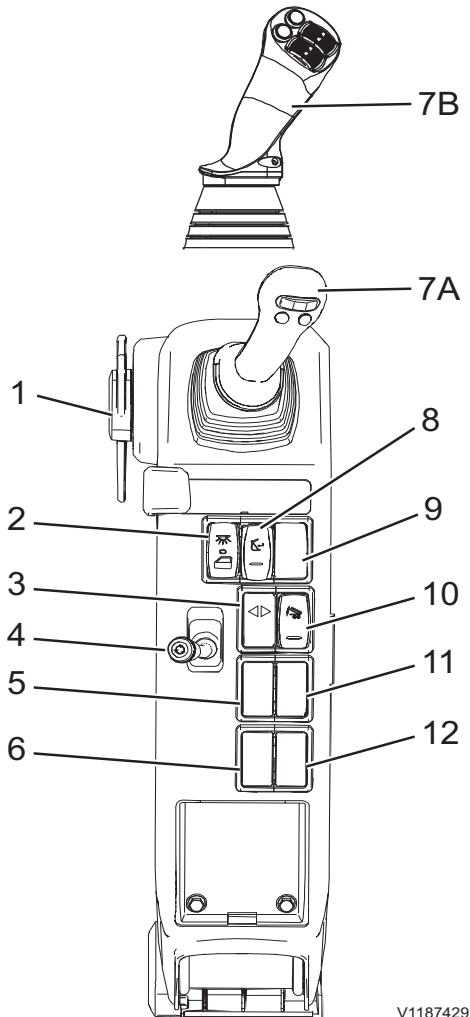

V1187429

Left instrument panel, standard machine

Left instrument panel, standard machine	
1.	Control lockout lever
2.	Cab interior light switch
3.	Trailer flashing indicator (optional equipment) (position 6 on machines without steering wheel)
4.	Control lever for stabiliser leg / stabiliser blade / dump trailer
5.	Unassigned / depending on options
6.	Unassigned / depending on options
7A.	Left control lever
7B.	Left control lever (L8-5 control lever)
8.	Attachment quick coupler confirmation switch
9.	Unassigned / depending on options
10.	Trailer lifting activation switch (optional equipment) (position 12 on machines without steering wheel)
11.	Unassigned / depending on options
12.	Unassigned / depending on options

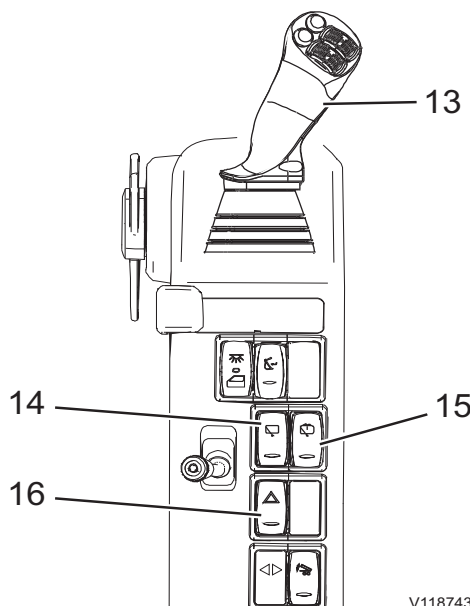

V1187430

Left instrument panel in combination with CDC without steering column

Left instrument panel in combination with Comfort Drive Control (CDC) without steering column (differences to standard instrument panel)	
13.	Left control lever (L8-5 control lever)
14.	Windscreen wiper switch
15.	Windscreen washer switch
16.	Hazard flasher switch

1. Control lockout lever

See page 110.

2. Cab interior light switch

- Press down the upper end of the switch to turn on the interior light.
- If the lower end of the switch is pressed down the interior light will be turned on when the cab door is open. After closing the cab door, the interior light will be turned off automatically.

Only when the upper end of the interior light switch is pressed down, the switch (A) for the lamp (B) on the cab ceiling will work. The reading light (D) can be turned on with the switch (C) regardless of the interior light switch.

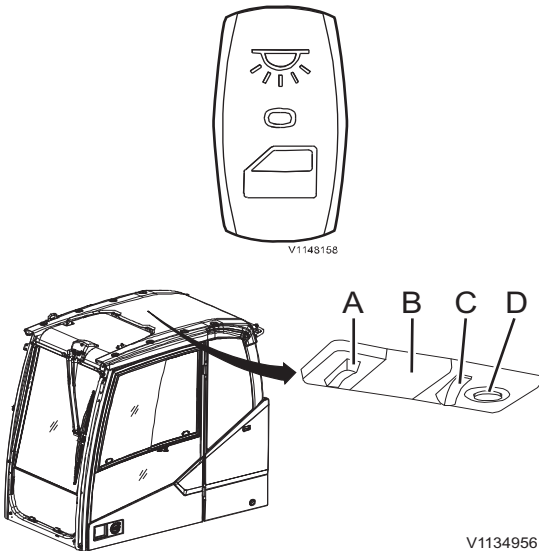

3. Trailer flashing indicator (optional equipment)

This lamp shows the correct function of the trailer direction indicators if trailer towing option is equipped, see page 234.

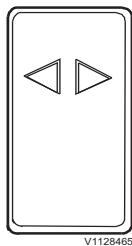

4. Control lever for stabiliser legs / stabiliser blade / dump trailer

(only without joystick controlled support)

If the machine is equipped with the optional joystick controlled support function this control lever (4) is not existing, in this case see point 7A / 7B for detailed description.

This control lever (4) is used for moving the stabiliser legs / stabiliser blade up and down after having selected the function in the IC (Instrument Cluster), see page 80.

- Move the lever (4) forwards to lower stabiliser legs / stabiliser blade.
- Move the lever (4) backwards to raise stabiliser legs / stabiliser blade.

Trailer lifting activation switch (10) in combination with this control lever (4):

- Press the upper end of the trailer lifting activation switch (10).
- Move the lever (4) forwards to tilt the loading platform of the attached trailer.

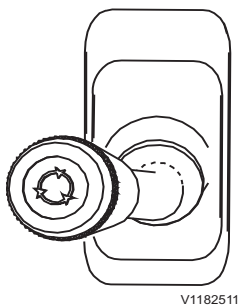

- If double acting option is equipped: Move the lever (4) backwards to tilt back the loading platform.

NOTE!

If the double acting trailer lifting option is engaged with the trailer lifting activation switch (10) in upper end position it is not possible to move the stabiliser legs / stabiliser blade. Disengage the double acting trailer lifting option by pressing the trailer lifting activation switch (10) to the lower end position.

- With the single acting option (standard for trailer towing option) this lever (4) is only tilting up the loading platform, tilting back is done by pressing the lower end of the trailer lifting activation switch (10).

5. Unassigned / depending on options

6. Unassigned / depending on options

7A. Left control lever / 7B. L8-5 Left control lever

Only valid for proportional control lever and L8-5 control lever: If the machine is equipped with the optional joystick controlled support function the left control lever is used for moving the stabiliser legs / stabiliser blade up and down after having activated the function.

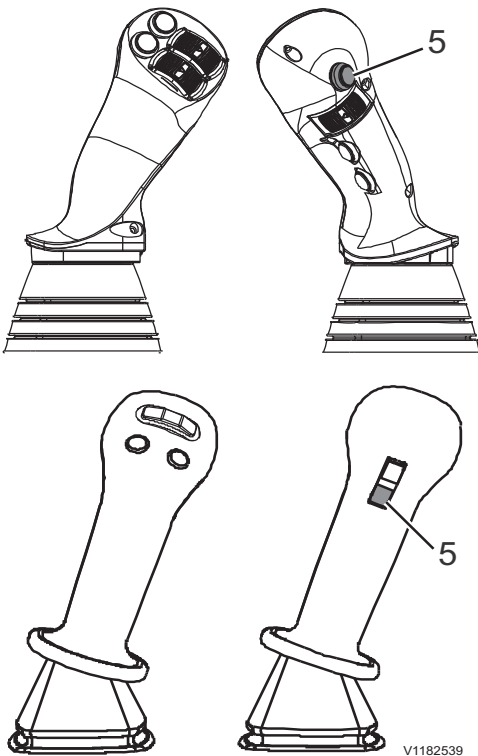

- The left control lever must be in neutral position.
- Press the button (5) on the left control lever once to activate joystick controlled support. The buzzer sounds when activated. Only for models with serial number start: EW160E 322329; EW7R180E 322114.
- The stabiliser control menu is shown in the IC (Instrument Cluster) as long as the left control lever is in neutral position. In this menu the stabilisers or blade (depending on machine configuration) to be moved can be selected.
- Move the left control lever forward to lower stabiliser legs / stabiliser blade. Move the left control lever backward to raise stabiliser legs / stabiliser blade.
- To deactivate the joystick controlled support function move the left control lever back to neutral position and press the button (5) again.

Trailer lifting activation switch (10) in combination with optional joystick controlled support:

- The left control lever must be in neutral position.
- Press the upper end of the trailer lifting activation switch (10).
- Press the button (5) on the left control lever once to activate the trailer lifting function.
- Move the left control lever forward to tilt the loading platform of the attached trailer.
- **If double acting option is equipped (optional equipment):** Move the left control lever backward to tilt back the loading platform.

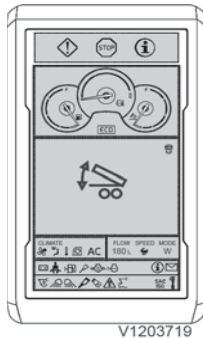

Trailer symbol visible when activated

- To deactivate the trailer lifting function move the control lever back to neutral position and press the button (5) again.

NOTE!

If the double acting trailer lifting option is engaged (trailer lifting activation switch (10) in upper end position) it is not possible to move the stabiliser legs / stabiliser blade. Disengage the double acting trailer lifting option by pressing the trailer lifting activation switch (10) to the lower end position.

- **With the single acting option** the left control lever is only tilting up the loading platform, tilting back is done by pressing the lower end of the trailer lifting activation switch (10).
- New function added only for models with serial number start: EW160E 322329; EW7R180E 322114. If both, the trailer switch and the function joystick controlled support are activated, a popup of the trailer symbol is shown in the display instead of the stabilizer menu.

For all other control lever functions see page 94.

8. Attachment quick coupler confirmation switch



Risk of crushing!

Attachments that move unexpectedly can cause injuries.

Make sure people stay out of the working area when connecting or disconnecting attachments.

NOTE!

The attachment quick coupler switch (position 11) on the right instrument panel must be pressed to initiate the opening of the attachment quick coupler. The buzzer sounds continuously after this switch is pressed. See page 80 for the operation.

Opening of the attachment quick coupler:

Press down and hold the upper end of the spring returned quick coupler confirmation switch on the left instrument panel for 1 second.

A red quick coupler symbol and a warning message for unlocked quick coupler will appear in the IC (Instrument Cluster).

Connect the attachment according to the operation description on page 210.

NOTE!

The attachment quick coupler switch (position 11) on the right instrument panel must be deactivated afterwards to initiate the closing of the attachment quick coupler. See page 80 for the operation.

Confirm closing of the attachment quick coupler:

After checking the correct locking of the attachment in the attachment quick coupler this has to be confirmed by pressing the upper end of the attachment quick coupler confirmation switch for 1 second.

A yellow quick coupler symbol and a check message for quick coupler locking confirmation will disappear in the IC (Instrument Cluster) and the buzzer sound will stop.

See page 210 for the complete procedure of the attachment quick coupler operation.



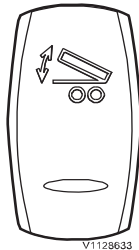

9. Unassigned / depending on options

10. Trailer lifting activation switch (optional equipment)

CAUTION

Risk of crushing.

Moving parts could cause crushing injury.

Ensure that no person is in the danger zone.

- 1 Press the upper end of the switch to enable the loading platform tilting.
- 2 Use control lever (4) or the left control lever (7) (depending on option) to tilt up the loading platform of the attached trailer.
- 3 If double acting option is equipped: Tilt the loading platform back again with the control lever (4) or the left control lever (7) (depending on option).
When the loading platform is in the correct position, the lower end of the switch should be pressed in order to disable the function.
- 4 If single acting option is equipped (standard for trailer towing option): Tilt the loading platform back again by pressing the lower end of the switch for dump trailer.

NOTE!

With the single acting option the loading platform is tilted down by its own weight when pressing the lower end of the switch. This can be a very fast movement.

11. Unassigned / depending on options

12. Unassigned / depending on options

13. Left control lever (L8–5 control lever)

See page 94 for information about the L8–5 control lever functions.

14. Windscreen wiper switch

- Upper end of switch pressed down = wiping on
- Switch in middle position = intermitted
- Lower end of switch pressed down = wiping off



15. Windscreen washer switch

Upper end of switch pushed down = start the washer.

The switch is spring-returned and goes back to off position after releasing it.



V1085712

16. Hazard flasher switch

The hazard flashers work even if the engine is not running.

Upper end of switch pressed down = hazard flasher on.

Lower end of switch pressed down = hazard flasher off.

40 Instrument panels
Instrument panel, front

Instrument panel, front

The front instrument panel can be adjusted for better operator comfort.

NOTE!

Prevent machine damage by taking correct action. Read thoroughly and understand the instructions in this section to familiarize yourself with the front instrument panel before trying to operate the machine.

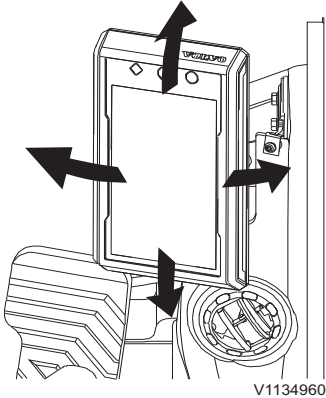

Adjustable direction of IC (Instrument Cluster)

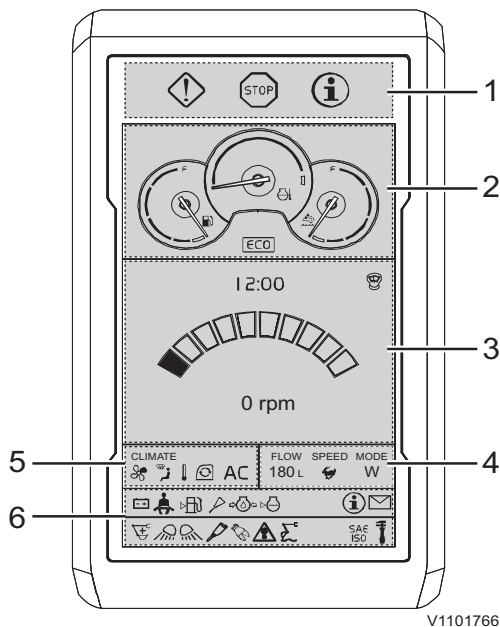

NOTE!

The front instrument panel is designed to display one of the supported languages. Refer to page 58 for details on how to set the language and the units.

- 1 Central warning light screen
- 2 Gauge screen
- 3 Time and engine speed screen
- 4 Mode screen
- 5 CCM (Climate Control Module) screen
- 6 Indicator screen

42 Instrument panels Instrument panel, front

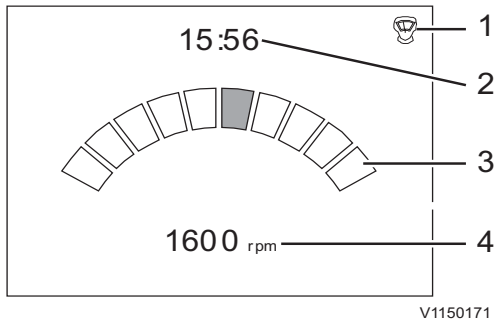

- 1 Control lever shortkey
- 2 Time
- 3 Engine speed step
- 4 Actual engine speed

AdBlue®/DEF level gauge

The gauge shows the level in the AdBlue®/DEF tank and it has a red mark indicating "AdBlue®/DEF empty". When the gauge is in this area, the AdBlue®/DEF left is about 10% of total tank capacity.

Capacity of AdBlue®/DEF tank, see page 338.

3 Time and engine speed

Control lever shortkey (1) is a button on the left control lever, see page 91 for the position of the button. One of 3 different functions for the shortkey can be set in the setup menu: Audio mute, wiper or camera.

The symbol shows the currently set function, refer to page 58 for instructions on how to set a shortkey function.

If the machine is equipped with a two-piece offset boom (optional equipment), the button on the left control lever is only dedicated to this function, see page 91.

Time segment (2) displays the current time. Refer to page 58 for instructions on how to set current time.

Engine speed screen (3) is displayed when the "Menu screen" is not shown in the "Main screen". For main menu screen, see page 50.

The "Engine speed step" selected on "Engine speed control switch" is displayed on an engine speed graph which is a segmented bar graph.

The actual speed (4) is displayed below the engine speed graph (maximum four-digit number).

When the engine is off, engine speed is displayed as "0".

NOTE!

Engine speed and work mode may vary according to the optional equipment.

4 Mode

- Mode: Shows the selected mode (parking, travel, working or customer mode)
- Speed: Shows the selected speed (high, low or creep speed)
- Flow: Shows the calculated value for X1 flow option, refer to page 58 for flow setting instructions.

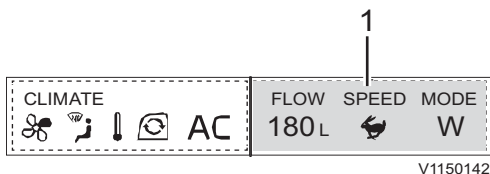

- 1 Mode screen

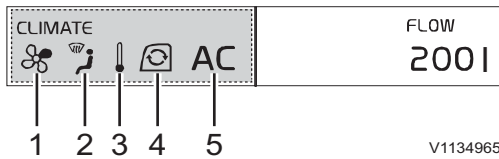

- 1 Fan speed
- 2 Air flow direction
- 3 Temperature
- 4 Air flow circulation
- 5 Air conditioning status

5 CCM (Climate Control Module)

CCM segment displays the status of the CCM (Climate Control Module). This includes temperature setting, fan speed, air flow direction, circulation, and air conditioning status. Refer to page 119 for more details.

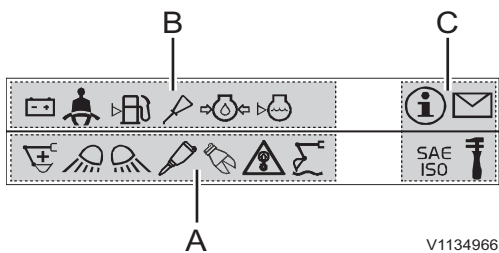

- A Function indicators
- B Warning indicators
- C Fixed indicators

6 Indicators

Indicator screen displays indicators as symbols that show users important information easily and quickly. Indicators are divided into three types; function indicator, warning indicator, and fixed indicator.

NOTE!

Fixed indicators are always displayed on the right side.



















- Indicators fill the space from left to right.
- An indicator that has higher priority is put on the left side of the one that has lower priority.
- Indicators on both sides can extend their display area to the other side if there is no indicator on the other side.
- When the whole area is filled and there are more indicators to display, indicators keep replacing the others so that the user can see all indicators.



44 Instrument panels
Instrument panel, front

Indicators and their priorities are as follows;

Table. Function indicators

 <small>V1085786</small> 1. Electric digging brake (Green = selected) (Yellow = applied) (Red = Warning indicator)	 <small>V1148913</small> 2. Boom Suspension System (BSS) (Yellow = in preparation) (Green = active)
 <small>V1065463</small> 3. Engine preheating on (Yellow)	 <small>V1186331</small> 4. Pivot axle automatically locked (Yellow)
 <small>V1187370</small> 5. Pivot axle unlocked (White)	 <small>V1085794</small> 6. Pivot axle manually locked (Green)
 <small>V1194561</small> 7. DPF regeneration needed (Yellow)	 <small>V1194562</small> 8. DPF regeneration ongoing or EATS temperature above 550 °C (Yellow)
 <small>V1194563</small> 9. Attachment quick coupler closed (Yellow)	 <small>V1194564</small> 10. Trailer lifting selected (Green)
 <small>V1194565</small> 11. Working light front on (Yellow)	 <small>V1194566</small> 12. Working light rear on (Yellow)
 <small>V1065465</small> 13. Single acting option hydraulic tool selected (Green)	 <small>V1065466</small> 14. Double acting option hydraulic tool selected (Green)
 <small>V1065467</small> 15. Overload warning selected (Green)	 <small>V1065468</small> 16. Boom float selected (Green)
 <small>V1148912</small> 17. Cruise control on (Green)	 <small>V1085799</small> 18. High beams on (Blue)



Instrument panels
Instrument panel, front

















 V1129236 19. Power boost on (Green)	 V1085819 20. Two-piece offset boom selected (Green)
 V1065469 21. Tiltrator detected (Green)	 V1065470 22. Reversible fan on (Green)
 V1184506 23. CDC selected (Green)	 V1194567 24. Joystick controlled support on (Green)
 V1194586 25. Grapple changeover on (Green)	

Table. Warning indicators

 V1065480 1. Battery charge warning (Red)	 V1065475 2. Engine oil pressure low warning (Red: critically below range) (Yellow: moderately below range)
 V1085792 3. Parking brake warning (Red)	 V1085786 4. Electric digging brake warning (Red)
 V1065488 5. Seat belt warning (Red) Fasten your seat belt.	 V1085803 6. Brake pressure low warning (Red)
 V1195691 7. Steering servo pressure low warning (Red)	 V1065483 8. Pattern change warning (Red)
 V1065481 9. Engine coolant temperature high warning (Red: critically above range) (Yellow: moderately above range)	 V1065479 10. Attachment quick coupler open warning (Red) Stop work immediately if the bucket is still attached to the attachment bracket.

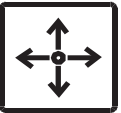

46 Instrument panels
Instrument panel, front















 <small>V1065467</small> 11. Overload warning (Red) Stop the lifting operation and reduce the load.	 <small>V1065487</small> 12. Hydraulic oil temperature high warning (Red)
 <small>V1065476</small> 13. Engine coolant level low warning (Red: critically below range) (Yellow: moderately below range)	 <small>V1065478</small> 14. Engine oil level low warning (Red: critically below range) (Yellow: moderately below range)
 <small>V1065484</small> 15. Engine air filter clogging warning (Yellow: critically above range)	 <small>V1194559</small> 16. Fuel water separation warning (Yellow)
 <small>V1194560</small> 17. SCR Warning (Yellow) (Alarm AdBlue®/DEF low level) (Alarm AdBlue®/DEF quality) (Alarm SCR Tampering)	 <small>V1065486</small> 18. Fuel level low warning (Yellow)
 <small>V1065485</small> 19. Auto grease low warning (Yellow) (Automatic lubrication system failure)	

Table. Fixed indicators

 <small>V1085789</small> 1. Turn alignment (White) (only in T-Mode) (Flashing: undercarriage and superstructure not aligned) (Solid: undercarriage and superstructure aligned)	 <small>V1065472</small> 2. Vehicle message (White) (only visible in case of an active failure)
 <small>V1065473</small> 3. Pattern change SAE/ISO (White)	 <small>V1065474</small> 4. Pattern change BHL (White)
 <small>V1065471</small> 5. Service mode active (White)	

Display unit

Start sequence

- 1 The Volvo logo lights up for a few seconds when the ignition key is turned to running position.
- 2 The initializing process of the operating system starts.

NOTE!

The engine can be started and the engine speed can be changed during this period.

- 3 Enter the code for the anti-theft system (if installed), see page 70. If the engine is started within 15 seconds (time adjustable with TechTool) after having turned it off, the code does not have to be entered again.
- 4 Daily maintenance is shown once a day for five seconds. This screen can be dismissed by pressing the ESC-button.
- 5 The standard screen appears.

NOTE!

The camera view is shown in the IC (Instrument Cluster) at every machine start, it could be closed with the ESC button.

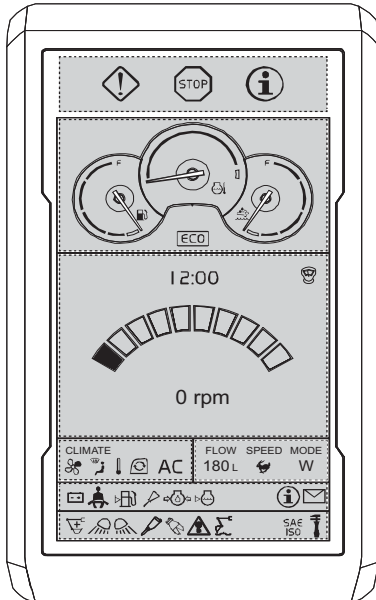

V1150143

Standard screen

Alarm texts

The information to the operator is provided on the IC (Instrument Cluster) in the form of alarm texts, which are divided into three classes: Information, Check and Warning.

Warning



V1161686

- This screen is to warn the operator when the electronic system senses a machine malfunction or a safety related failure.
Stop the machine immediately and check the alarm text in the display for the alarm reason and the required action.
- The alarm text is shown in a red box and provides information on reason for alarm and required action.
- The red central warning symbol is shown.
- The buzzer will sound until the required action has been performed.
- The alarm text and the red central warning symbol will be shown until the required action has been performed.
- Repair if possible or contact a qualified service technician.

Caution / Check



V1161687

- This screen is to inform the operator when a partial failure of the machine is detected.
Check the alarm text in the display for the alarm reason and the required action.
- The alarm text is shown in a yellow box and provides information on reason for alarm and required action.
- The amber central warning symbol is shown.
- The buzzer sounds four times.
- Press SELECT button to obtain more information about the malfunction.
- The alarm text is shown until confirmation is performed by pressing ESC button.
- Repair if possible or contact a qualified service technician.

Information



V1161688

- This screen is to give useful information about the machine.
Check the alarm text in the display for the alarm reason and the required action.
- The alarm text is shown in a blue box and provides information on reason for alarm and required action.
- The blue information symbol is shown.
- The buzzer sounds two times.
- The alarm text is shown for eight seconds and then changes to operating display, or can be hidden immediately by pressing ESC button.
- Repair if possible or contact a qualified service technician.



Results / Function description

Furthermore there are two more levels of information screens: Results and Function descriptions.

Results

- This screen is for presentation of results from an operator selected action.
This is only an information and does not require any further action.
- The text is shown in a white box and provides the result of a selection.
- The buzzer does not sound.
- The text will hide by pressing the ESC button.

Function description

- This screen provides help for the operator on activated functions.
- The text is shown in a green box and provides information about an activated function.
- The buzzer sounds one time.
- The text is shown for eight seconds and then changes to operating display, or can be hidden immediately by pressing ESC button.

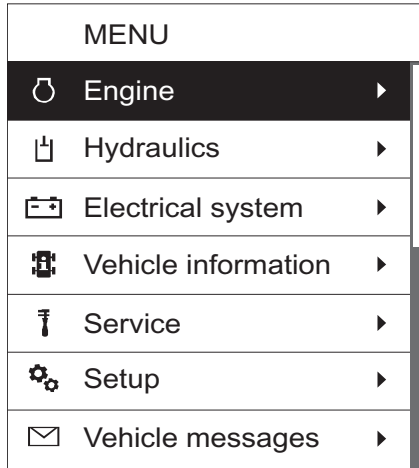

V1137861

Main menu

Main menu

The main menu is reached by pressing the SELECT button on the keypad.

Scroll the list by using the arrow buttons on the keypad.

When an item in the main menu is highlighted, its subscreens are shown when pressing the SELECT button. Use the arrow buttons to scroll between the subscreens.

The action can be cancelled at any time by pressing the ESC button on the keypad.

Subscreens

The main menu in the IC (Instrument Cluster) contains the following subscreens:

Engine, Hydraulics, Electrical system, Vehicle information, Service, Setup, Vehicle messages

Engine

- **Oil pressure:** This shows the measured value of the engine oil pressure. When the bar graph is green, the value is OK, within normal operation range. When the bar graph is red, the value is abnormal.

- **Oil level:** This indicator shows the measured value of the engine oil level. The color of the indicator shows the following:
 - Green:** The value is between 30%-100%, the oil level is okay.
 - Yellow:** The value is between 3%-30%, check the oil level with the dipstick at next daily maintenance.
 - Red:** The value is between 0%-3%, the oil level too low. Check the level immediately with the dipstick and take the necessary actions.
 - Grey:** System failure.

- **Regeneration:** See page 165 for information how to run a parked regeneration.

- **DPF soot level:** See page 165 for information how to run a parked regeneration.

- **DPF soot level:** This shows the level of soot that has accumulated within the DPF. The soot level screen can be used to optimize DPF regenerations based upon the work cycle of the machine. A parked regeneration will be required if the soot level exceeds 100%.

- **DPF Regen progress (only for parked regeneration):** This shows the measured value of DPF regeneration progress during a parked regeneration. Regeneration is complete when the bar graph reaches 100%. During normal operation, passive regeneration occurs continuously.

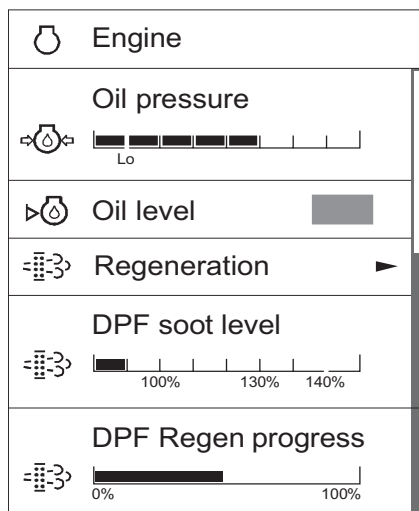

V1155792

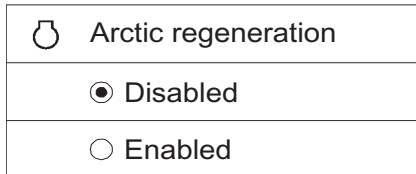
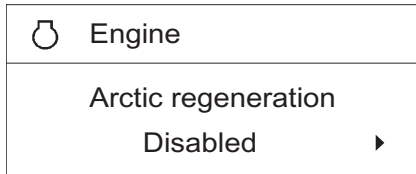

V1147262

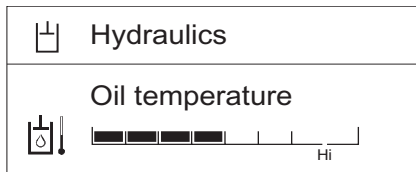

V1137863

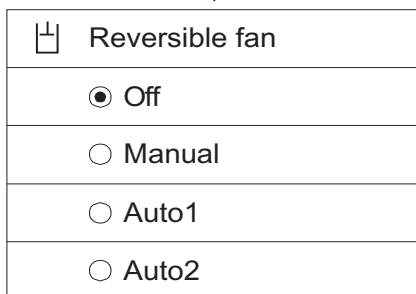
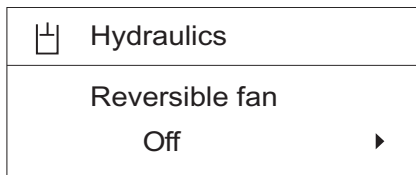

V1137864

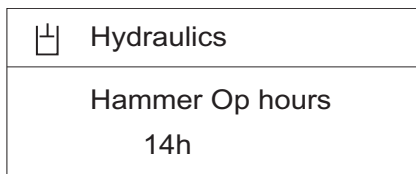

V1137868

- Arctic regeneration (optional equipment):** Arctic regeneration mode is used for machines that operate in extreme cold climate areas where the machines need to be left running around-the-clock without operator presence. To use this optional mode, the parked regeneration mode should be selected in advance. When selecting "Enabled" in this menu, the parked regeneration mode is started automatically when needed without any further operator action. This function will only be active while in parked mode, regardless of regeneration mode and will be "Disabled" by default at startup or when leaving the parked mode. This means that the regeneration system can remain in an optimal mode, even after longer periods of idling.
 - Disabled
 - Enabled

Hydraulics

- Oil temperature:** This shows the measured value of hydraulic oil temperature. When the bar graph is green, the value is OK, within normal operation range. When the bar graph is red, the value is abnormal.
- Reversible fan (optional equipment):** This informs the operator which mode is selected at the moment. It also allows the operator to select a reversible fan mode from 4 different modes. The operator can select a reversible fan mode with the arrow buttons. When pressing the SELECT button, the marked mode is set. The screen reverts to the former screen displaying the newly selected mode.
 - Off mode:** Normal rotation or stopping reverse rotation.
 - Manual mode:** Reverses the rotation one cycle immediately after setting the mode.
 - Auto1 mode / Auto2 mode:** Repeats a cycle consisting of normal rotation and reverse rotation. For more information, see page 206.

- Hammer op. hours (optional equipment):** This shows the counted value of hammer operating time in the unit hours.

Hydraulics
X1 work tool HAMMER ▶



X1 work tool
<input checked="" type="radio"/> HAMMER
<input type="radio"/> SHEAR

V1137869

Hydraulics
X1 response mode Active ▶



X1 response mode
<input checked="" type="radio"/> Active
<input type="radio"/> Normal
<input type="radio"/> Soft

V1160339

Hydraulics
X3 response mode Active ▶



X3 response mode
<input checked="" type="radio"/> Active
<input type="radio"/> Normal
<input type="radio"/> Soft

V1137870

Pump flow
Set pump flow: ◆ 15 %

V1154717

- **X1 work tool (optional equipment):** This informs the operator which tool is selected at the moment. It also allows the operator to select a preset tool showing the name and settings of each tool. When pressing the arrow button, another preset work tool is displayed. When pressing the SELECT button for another tool, the screen reverts the screen to the former screen displaying the name of the newly selected tool.

- **X1 response mode (optional equipment):** This informs the operator which X1 response mode is selected at the moment. It also allows to select a response mode from 3 different modes. The operator can select an X1 response mode from the three modes with the arrow buttons. When pressing the SELECT button, the marked response mode is set. The screen reverts to the former screen displaying the name of the newly selected item.

Active
Normal
Soft

The operator can adjust the movement sensitivity of attachments when operating the levers. "Soft" mode is the most sensitive.

- **X3 response mode (optional equipment):** This informs the operator which X3 response mode is selected at the moment. It also allows to select a response mode from 3 different modes. The operator can select a X3 response mode from the three modes with the arrow buttons. When pressing the SELECT button, the marked response mode is set. The screen reverts to the former screen displaying the name of the newly selected item.

Active: maximum performance of 70 l/min (18.5 US gal/min)
Normal: oil flow limited to approx. 45 l/min (11.9 US gal/min)
Soft: oil flow limited to approx 25 l/min (6.6 US gal/min)
The operator can adjust the movement sensitivity of attachments when operating the levers. "Soft" mode is the most sensitive.

- **Pump flow adjustment:** The pump flow maximum value can be adjusted.

The pump flow displayed is the maximum flow setting when operating in C-mode.

NOTE!

The pump flow is not adjustable in T- and W-mode.

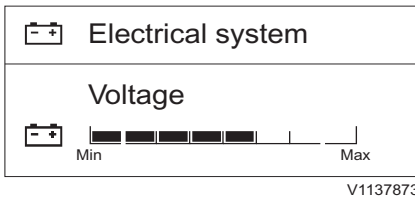

Electrical system

- **Voltage:** This shows the measured value of voltage of the battery. When the bar graph is green, the value is OK, within normal operation range. When the bar graph is red, the value is abnormal.

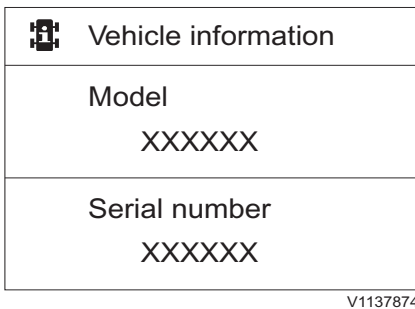

Vehicle information

- **Model:** This shows the machine's model name.
- **Serial number:** This shows the machine's serial number.

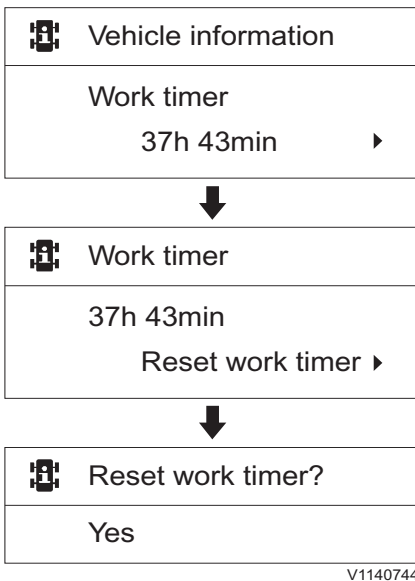

- **Operating hours:** This shows the total operating hours of the machine, reset of this value is not possible.
- **Work timer:** This shows the counted work time.
- **Reset work timer:** Work time can be reset by pressing the SELECT button when the "Work timer" value is highlighted. Press ESC button to "Cancel" or SELECT button to "Yes".

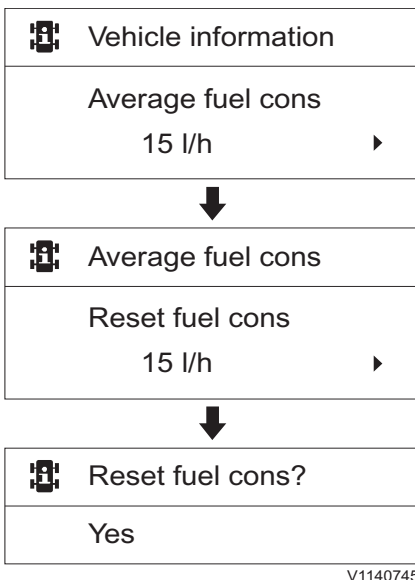

- **Average fuel cons.:** This shows the calculated average fuel consumption from the last 24 hours.
- **Reset fuel cons:** Fuel consumption can be reset by pressing the SELECT button when the "Average fuel cons" value is highlighted. Press the ESC button to "Cancel" or SELECT button to "Yes".

	Vehicle information
	Current fuel cons Lo Hi
	Ambient temperature 25.0 °C

V1137877

- **Current fuel cons.:** This shows the calculated fuel consumption at the current time.
- **Ambient temp:** This shows the measured ambient temperature.

Service

This subscreen shows the service items with “time remaining” value. Press the SELECT button to adjust interval or to check detail information.

	Service
	Engine oil/filter 450h ▶



	Engine oil/filter
	Interval: 500h Set interval ▶



	Engine oil/filter
	Set interval: ◆ 500h

V1137878

	Engine oil/filter
	Time remaining: 450h Reset time remain ▶

V1137879

	Reset time remaining?
	Yes

V1140746

- **Engine oil/filter**
- **Interval:** This shows the value of engine oil/filter interval in the unit hours. According to engine oil/filter type, the operator can adjust engine oil/filter interval. The setting range is 50 ~ 500 hours.

- **Time remaining:** This shows the value for remaining time to next engine oil/filter service. When the "Time remaining" reaches 40 h, 20 h, and 0 h, the check screen with "Time remaining" and "Interval" will pop up on the IC (Instrument Cluster). Service the maintenance items which should be serviced in that interval. For the service interval and maintenance items, see page 268.
- **Reset time remaining?:** After servicing the maintenance items, the time can be reset. Press ESC button to "Cancel" or SELECT button to "Yes". When the time is reset, the next service interval and "Time remaining" will be displayed. If the operator does not replace the engine oil/filter and resets this value, it turns to zero and then to negative.



 Service
Fuel filter/Water sep 450h ▶



 Fuel filter/Water sep
Interval: 500h Set interval ▶



 Fuel filter/Water sep
Set interval: ◆ 500h

V1137881

 Fuel filter/Water sep
Time remaining: 450h Reset time remain ▶

V1137882

 Reset time remaining?
Yes

V1140746

 Service
Hydraulic oil 1500h ▶



 Hydraulic oil
Interval: 2000h Set interval ▶



 Hydraulic oil
Set interval: ◆ 2000h

V1137883

■ Fuel filter/Water sep

■ **Interval:** This shows the value of fuel filter/water separator interval with in the unit hours. The operator can adjust fuel filter/water separator interval. The setting range is 50 ~ 500 hours.

■ **Time remaining:** This shows the value for remaining time for next fuel filter/water separator service. When the "Time remaining" reaches 40 h, 20 h, and 0 h, the check screen with "Time remaining" and "Interval" will pop up on the IC (Instrument Cluster). Service the maintenance items which should be serviced in that interval. For the service interval and maintenance items, see page 268.

■ **Reset time remaining?:** After servicing the maintenance items, the time can be reset. Press ESC button to "Cancel " or SELECT button to "Yes". When the time is reset, the next service interval and "Time remaining" will be displayed. If operator does not maintain the parts and reset this value it turns to zero and then to negative.

■ Hydraulic oil

■ **Interval:** This shows the value of hydraulic oil interval in the unit hours. The operator can adjust the hydraulic oil interval. The setting range is 100 ~ 5000 hours.



 Hydraulic oil
Time remaining: 1500h Reset time remain ▶

V1137884

 Reset time remaining?
Yes

V1140746

 Hydraulic oil
Hammer Op hours: 20h

V1137885

 Service
Hydraulic oil filter 1500h ▶



 Hydraulic oil filter
Interval: 2000h Set interval ▶



 Hydraulic oil filter
Set interval: ◆ 2000h

V1137886

 Hydraulic oil filter
Time remaining: 1500h Reset time remain ▶

V1137887

 Reset time remaining?
Yes

V1140746

■ **Time remaining:** This shows the value for remaining time to next hydraulic oil service. When the "Time remaining" reaches 40 h, 20 h, and 0 h, the check screen with "Time remaining" and "Interval" will pop up on the IC (Instrument Cluster). Service the maintenance items which should be serviced in that interval. For the service interval and maintenance items, see page 268.

■ **Reset time remaining?:** After servicing the maintenance items, the time can be reset. Press ESC button to "Cancel " or SELECT button to "Yes". When the time is reset, the next service interval and "Time remaining" will be displayed. If operator does not maintain the parts and reset this value it turns to zero and then to negative.

■ **Hammer op. hours:** This shows the counted value of hammer operating time in the unit hours. "Hammer op. hours" is not adjustable. It is automatically reset to zero when "Time remaining" is reset and shows the hammer operating hours from the reset point.

■ **Hydraulic oil filter**



■ **Interval:** This shows the value of hydraulic oil filter interval in the unit hours. The operator can adjust the hydraulic oil filter interval. The setting range is 100 ~ 2000 hours.

■ **Time remaining:** This shows the value for remaining time to next hydraulic oil filter service. When the "Time remaining" reaches 40 h, 20 h, and 0 h, the check screen with "Time remaining" and "Interval" will pop up on the IC (Instrument Cluster). Service the maintenance items which should be serviced in that interval. For the service interval and maintenance items, see page 268.



■ **Reset time remaining?:** After servicing the maintenance items, the time can be reset. Press ESC button to "Cancel " or SELECT button to "Yes". When the time is reset, the next service interval and "Time remaining" will be displayed. If operator does not maintain the part and reset this value it turns to zero and then to negative.

 Hydraulic oil filter
Hammer Op hours: 20h

V1137888

 Vehicle messages
 Engine system ▶



 Check at next stop
 System failure (Engine system) Fault Active: Yes Error Code: P203A86 Source: ECM First Event: 20140101 No. Events: 2 Last Event: 20140101

V1137911

- **Hammer op. hours:** This shows the counted value of hammer operating time in the unit hours. "Hammer op. hours" is not adjustable. It is automatically reset to zero when "Time remaining" is reset and shows the hammer operating hours from the reset point.

Setup

The subscreen **Setup** contains several sub-items for setup changes, see page 58 for details.

Vehicle messages

- This shows the headlines of messages. There are no errors or warning messages in normal operation. If an abnormal condition is sensed, then the message will display the specific error/failure. Contact a qualified service technician, if needed. When pressing the SELECT button to view detail information about a headline, the displayed information replaces the whole "main screen". The information content includes:

- Fault Active**
- Error Code**
- Source**
- First Event**
- No. of events**
- Last event**

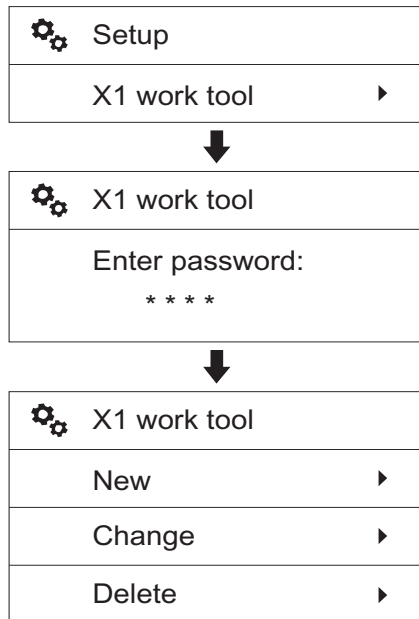

V1137889

Setups

The **Setup** menu in the IC (Instrument Cluster) contains following sub-items:

X1 work tool, X3 Operation, CDC steering speed, Steelwrist setup, Auto idle time, Joystick shortkey, Language, Units, Time/date, Display light and Keypad backlight.

X1 work tool

This is to preset the X1 setting so that operators can use it simply by selecting the tool from the list.

- **Enter password (optional):** Enter the password to proceed with the setting for X1 tools. The password screen is displayed whenever the password is set using Volvo's service tool.

Select the preferred item using the arrow buttons.

Save the selected item using the SELECT button. Use the ESC button to cancel without saving.

There are 3 possibilities:

- New**
- Change**
- Delete**

- **New:** The "New" setting is used to add new X1 tools. Follow the steps from 1 through 8, described below, to set and "Save" the parameters for the new attachment.



NOTE!

If the "Save" procedure described in 8 is not performed, all settings are cancelled automatically.

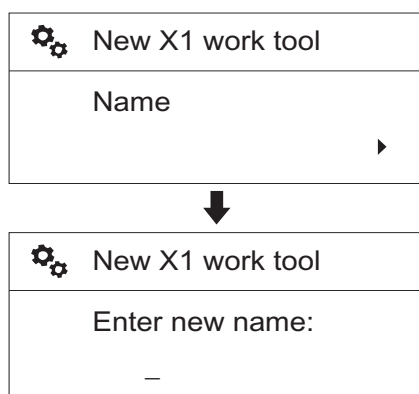
- 1 Select **"New"** after entering **"X1 work tool"**.
- 2 **Name:** Enter the name of the tool.
 - Use the arrow UP and arrow DOWN button to select the characters (A,B...Z,0,1...9).
 - Use the SELECT button to enter the selected character. Use the ESC button to delete the entered character.
 - Press the SELECT button once again to save the name.





V1137890

 New X1 work tool
Flow 280 l 



 New X1 work tool
Set flow: ◆ 280 l



V1137891

 New X1 work tool
Pressure 220 bar 



 New X1 work tool
Set pressure: ◆ 220 bar

V1137892

 New X1 work tool
Control Push 



 New X1 work tool
<input checked="" type="radio"/> Push
<input type="radio"/> Toggle
<input type="radio"/> Proportional

V1137893

- 3 **Flow:** Set the flow rate when this optional function is selected.
- Select the preferred flow rate value using the arrow buttons.
 - Save the selected value using the SELECT button. Use the ESC button to cancel without saving.

- 4 **Pressure:** Set the pressure when this optional function is selected.
- Select the preferred pressure value using the arrow buttons.
 - Save the selected value using the SELECT button. Use the ESC button to cancel without saving.

- 5 **Control:** Choose the control type for the X1 tool.
- Select the preferred control type using the arrow buttons.
 - Save the selected item using the SELECT button. Use the ESC button to cancel without saving.
- Possible control types are:
- Push**
 - Toggle**
 - Proportional**
- For information on control types, see page 79.

	New X1 work tool
Pedal control	
Push ▶	



	New X1 work tool
<input checked="" type="radio"/> Push	
<input type="radio"/> Toggle	
<input type="radio"/> Proportional	

V1137894

	New X1 work tool
Attachment	
1 way ▶	



	New X1 work tool
<input checked="" type="radio"/> 1 way	
<input type="radio"/> 2 way	

V1137895

	New X1 work tool
Save	

V1137896

	X1 work tool
Change ▶	



	Change X1 work tool
<input type="radio"/> HAMMER	
<input type="radio"/> SHEAR	
<input checked="" type="radio"/> VOLVO	

V1137897

- 6 **Pedal control:** Choose the pedal control type.
- Select the preferred control type using the arrow buttons.
 - Save the selected item using the SELECT button. Use the ESC button to cancel without saving.
- Possible control types are:
- Push**
Toggle
Proportional
- For information on control types, see page 79.

- 7 **Attachment:** Choose the **1 way** or **2 way** control.
- Select the preferred setting using the arrow buttons.
 - Save the selected item using the SELECT button. Use the ESC button to cancel without saving.

- 8 **Save:** Save the setting.
- Select "Save" and press the SELECT button to save all settings including "Name", "Flow", "Pressure", "Control", "Pedal control", and "Attachment".

NOTE!

After entering the new settings, the "Save" procedure should be performed to record the new parameters in the system memory. If the "Save" procedure is not performed, all the settings will be cancelled automatically.

- If some items are not set up, the error message "Fill out all items" will appear.

- 9 The added X1 tool is newly listed.

■ **Change**

This is to modify the setting of preset X1 tools.

- 1 Select **"Change"** after entering **"X1 work tool"**.
- 2 Select the tool to be modified using the arrow buttons and press the SELECT button.
- 3 Follow the same procedures from 2 to 8 explained in **"New"** section described above to change the setting.
- 4 There are some restrictions when modifying the setting:
 - The "Name" of two default X1 tools "HAMMER" and "SHEAR" are not modifiable.
 - The "HAMMER" cannot be "2-way".
- 5 The modified X1 tool is listed.

	Setup
	X3 operation ▶



	X3 operation
	Enter password: * * * *



	X3 operation
	Control: Push ▶



	X3 operation
	<input checked="" type="radio"/> Push
	<input type="radio"/> Toggle
	<input type="radio"/> Proportional

V1140748

	X3 OPERATION
	Control: Toggle ▶
	<input checked="" type="checkbox"/> Change X3 direction

V1203717

	CDC steering speed
	<input type="radio"/> Active
	<input checked="" type="radio"/> Normal
	<input type="radio"/> Soft

V1185604

X3 Operation

This is to select the control type for the X3 operation.

- **Enter password (optional):** Enter the password to proceed with the setting for X3 tools. The password screen is displayed whenever the password is set using Volvo's service tool.
 - Select the preferred control type using the arrow buttons.
 - Save the selected item using the SELECT button. Use the ESC button to cancel without saving.

Possible control types are:

Push

Toogle

Proportional

For information on control types, see page 79.

- **Change X3 direction (New function)**

Only for models with serial number start:

EWR150E 322552; EW160E 322344; EWR170E 320079;

EW180E322119; EW220E 320043

- For changing the X3 direction click the checkbox.

CDC steering speed

This is to select the steering speed of the Comfort Drive Control (CDC) (optional equipment) in dependency of the travel speed. During standstill the speed response is always at maximum.

- Select the preferred steering speed using the arrow buttons.
- Save the selected item using the SELECT button. Use the ESC button to cancel without saving.

Possible steering speeds are:

active

normal

soft

The factory setting is **normal**.

	Steelwrist setup
	Steelwrist tool
	Profile 1 ▶



	Steelwrist setup
<input checked="" type="radio"/>	Profile 1
<input type="radio"/>	Profile 2
<input type="radio"/>	Profile 3
<input type="radio"/>	Profile 4

V1185605

	Steelwrist setup
	Steelwrist tool
	Profile 1 ▶
	Change profile ▶



	Change profile
<input type="radio"/>	Profile 1
<input checked="" type="radio"/>	Profile 2
<input type="radio"/>	Profile 3
<input type="radio"/>	Profile 4

V1185607

	Steelwrist setup
	Response mode



	Response mode
<input type="radio"/>	Active
<input checked="" type="radio"/>	Normal
<input type="radio"/>	Soft

V1185608

Steelwrist setup

This is to setup the Steelwrist attachment (optional equipment).

Profiles

A profile stores settings for different work tools or different operators.

Up to four different profiles can be set. This makes it possible to quickly shift settings for different attachments or operators.

Select profile

- Select the preferred profile using the arrow buttons.
- Save the selected item using the SELECT button. Use the ESC button to cancel without saving.

Change profile

This is to change the settings of a selected profile.

- Select the profile which shall be changed using the arrow buttons.
- Open the selected item using the SELECT button.



1 Response mode

With this setting the response mode in the selected profile can be adjusted.



- Select the preferred response mode using the arrow buttons.
- Save the selected item using the SELECT button. Use the ESC button to cancel without saving.

Possible response modes are:



active
normal
soft

 Steelwrist setup
Response mode
Tilt speed 
<input checked="" type="checkbox"/> Change Tilt direction

V1185609

 Steelwrist setup
Rotation speed 
Gripper speed 

V1185610

 Steelwrist setup
AUX Function LH Lever ▶
↓
 AUX Function LH Lever
<input checked="" type="checkbox"/> Volvo X-Function
<input type="checkbox"/> Steelwrist AUX

V1185611

2 Tilt speed

With this setting the maximum speed of the tilt function can be adjusted in the selected profile.

The adjusting bar in the screen is controlled with the arrow buttons and the value is set with the SELECT button.

Use the ESC button to cancel without saving.

3 Change tilt direction

With this setting the tilt direction of the tiltrotator can be changed in the selected profile:

- not selected: tilting clockwise
- selected: tilting counterclockwise

4 Rotation speed

With this setting the maximum rotation speed of the tiltrotator can be adjusted in the selected profile.

The adjusting bar in the screen is controlled with the arrow buttons and the value is set with the SELECT button.

Use the ESC button to cancel without saving.

5 Gripper speed

With this setting the maximum speed of the gripper opening and closing can be adjusted in the selected profile.

The adjusting bar in the screen is controlled with the arrow buttons and the value is set with the SELECT button.

Use the ESC button to cancel without saving.

NOTE!

The speed may have to be reduced on extra function to allow handling of work tools with limited hydraulic capabilities.

6 AUX function LH lever

Depending on which hydraulic line supplies the Steelwrist, either X1 or X3 (see point 9 "Main hydraulic supply"), the AUX function on the left control lever is connected to the other hydraulic line.

In this menu the roller switch for additional hydraulics on the left control lever (see L8–5 control levers on page 94 and following) can be allocated to "Volvo X function" or "Steelwrist AUX".

a Volvo X-Function

The Volvo X-Function can be used to control an attachment or tool which is connected to the free hydraulic line.

The tool type and size which can be connected depends on if the free hydraulic line is X1 or X3.

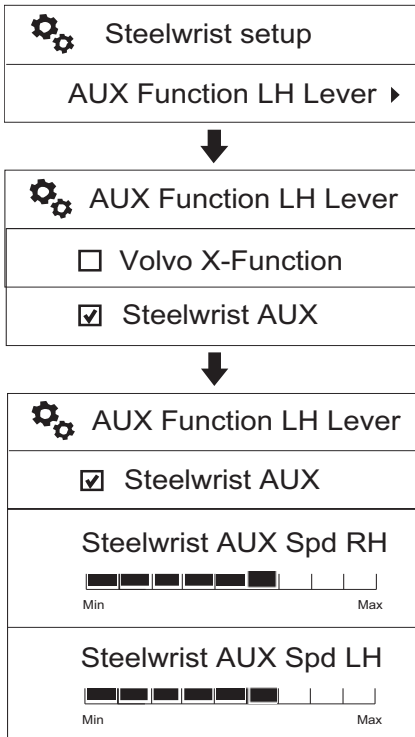

b Steelwrist AUX

The Steelwrist AUX is a function within the Steelwrist system which can be used to connect more attachments or tools, please refer to the Steelwrist manual for more information.

- **Steelwrist AUX Spd RH**

With this setting the maximum speed of the right hand steelwrist AUX function can be adjusted in the selected profile.

The adjusting bar in the screen is controlled with the arrow buttons and the value is set with the SELECT button. Use the ESC button to cancel without saving.

- **Steelwrist AUX Spd LH**

With this setting the maximum speed of the left hand steelwrist AUX function can be adjusted in the selected profile.

The adjusting bar in the screen is controlled with the arrow buttons and the value is set with the SELECT button. Use the ESC button to cancel without saving.

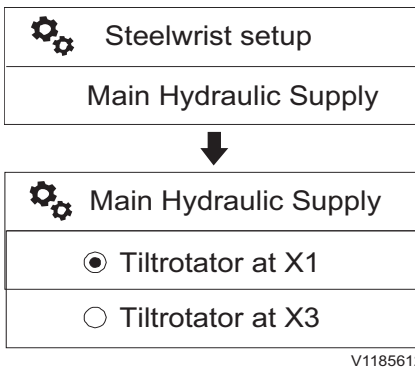

7 Main hydraulic supply

With this setting the function for the main hydraulic supply can be changed in the selected profile: either X1 or X3.

- Select the preferred main hydraulic supply using the arrow buttons.
- Save the selected item using the SELECT button. Use the ESC button to cancel without saving.

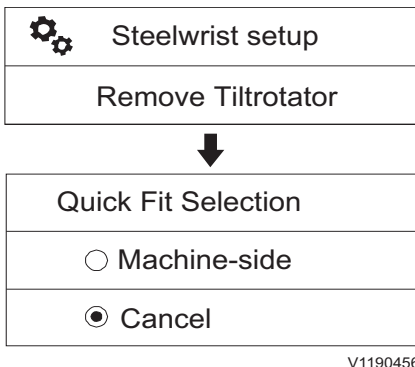

8 Fully hydraulic quick coupler preparation (Remove Tiltrotator)

With this function a tiltrotator with a fully hydraulic quick coupler can be disconnected from the machine quick coupler without leaving the cab.

This menu item can only be set if a fully hydraulic quick coupler is connected to the machine.

- By default the setting is "cancel".
- To enable the machine quick coupler: select "Machine-side" by using the arrow buttons.
- The pop up message "Machine quick fit enabled" is shown in the IC (Instrument Cluster) for 15 seconds.
- During this time the quick coupler switches (see pages 34 and 80) are dedicated to the machine quick coupler to disconnect the tiltrotator.
- Disconnect the tiltrotator from the machine quick coupler.
- Afterwards the pop up message disappears.

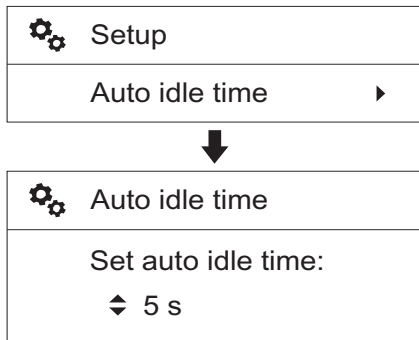

V1137900

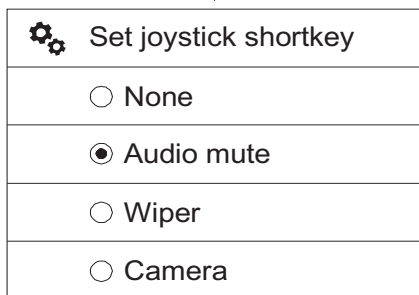
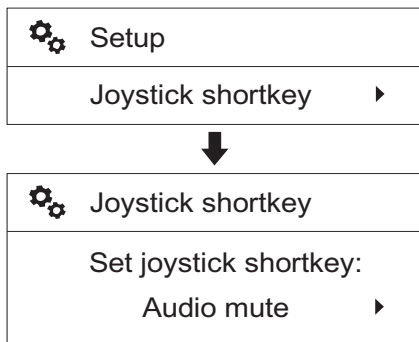

V1150174

- If the quick coupler switches are not used during the 15 seconds the pop up message disappears and the machine quick coupler is disabled again. The pop up message could also be closed with the ESC button.
- Use the ESC button to leave the menu.

Auto idle time

The basic concept of “Auto idle” is to reduce fuel consumption. The engine rpm will be lowered automatically to idle mode, if the Auto idle button is ON and any of control levers (pedals) or engine speed control switch are not operated for a certain time.

The Auto idle time can be set from 3 seconds to 20 seconds with the arrow buttons and the value is set with the SELECT button. Use the ESC button to cancel without saving.

Joystick shortcut (Multi function button)

This function allows the operator to use a function easily with a button of the control lever. See page 94 and following for the position of the shortcut button.

- Select the preferred function for the joystick shortcut using the arrow buttons.
- Save the selected item using the SELECT button. Use the ESC button to cancel without saving. Possible functions are:
None (no function)
Audio mute
Wiper
Camera

Also the selected item is displayed with a symbol on the IC (Instrument Cluster).

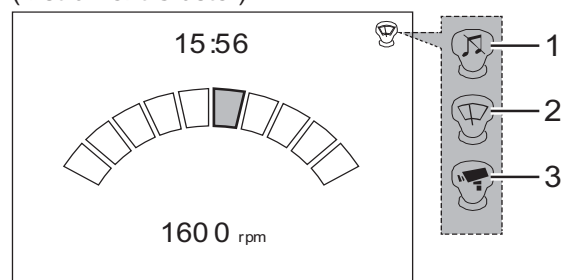

V1150155

- 1 Audio mute
- 2 Wiper
- 3 Camera

Special features of multifunction button:

- If **Audio mute** is selected and the multifunction button is pressed for a while, the radio is switched off.
- If **Wiper** is selected and the multifunction button is pressed for a while, the washer is also switched on.

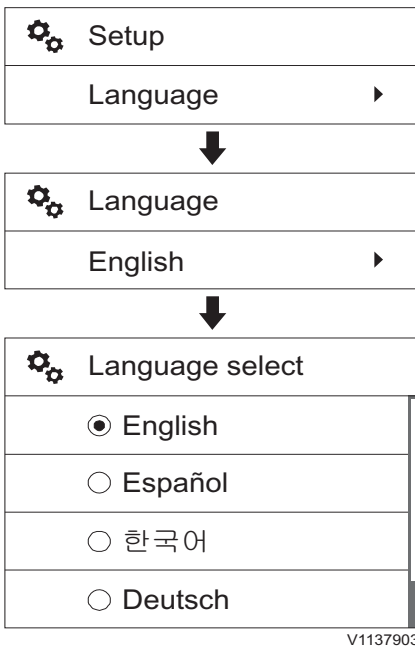

Language

Supported languages are listed in the screen in the form of their own languages.

- Select the preferred language using the arrow buttons.
- Save the selected item using the SELECT button. Use the ESC button to cancel without saving.

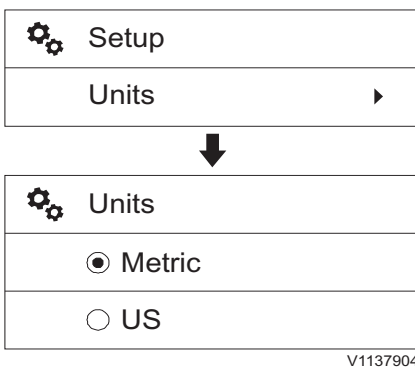

Units

Two unit systems are displayed: "Metric" and "US".

- Select the preferred unit using the arrow buttons.
- Save the selected item using the SELECT button. Use the ESC button to cancel without saving.
- The units stored in the IC (Instrument Cluster) are as follows:

Item	Metric	US
Time	h	h
Fluid rate	l/h	USgal/h
Volume	L	USgal
Voltage	V	V
Current	A	A
Temperature	°C	°F
Revolution	rpm	rpm
Speed	km/h	mph
Pressure	bar	psi
Distance	km	mile

⚙️ Setup
Time/date ▶



⚙️ Time/date
Date set 20140101 ▶



⚙️ Set date
yyymmdd: ↕ 20140101

V1137905

⚙️ Time/date
Time set 12:30 ▶



⚙️ Set time
24h: ↕ 12:30

V1137906

⚙️ Time/date
Date format yyymmdd ▶



⚙️ Date format
<input checked="" type="radio"/> yyymmdd
<input type="radio"/> mmddyyyy
<input type="radio"/> ddmmyyyy

V1137907

Time/Date

- Date set:** This is for adjusting the date. The preset date format is shown in the first row of the screen.

 - Adjust each segment of the time with the arrow buttons and save the setting with the SELECT button. Use the ESC button to cancel without saving.

- Time set:** This is for adjusting the time. The preset clock format is shown in the first row of the screen.

 - Adjust each segment of the time with the arrow buttons and save the setting with the SELECT button. Use the ESC button to cancel without saving.

- Date format:** The items "yyymmdd", "mmddyyyy", and "ddmmyyyy" decide how the IC (Instrument Cluster) shows the date. "yyyy" means year, "mm" means month, and "dd" means day.

 - Select the preferred format using the arrow buttons.
 - Save the selected item using the SELECT button. Use the ESC button to cancel without saving.

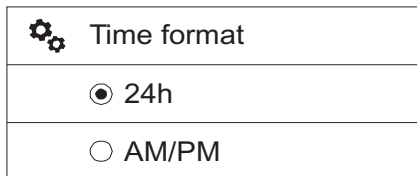
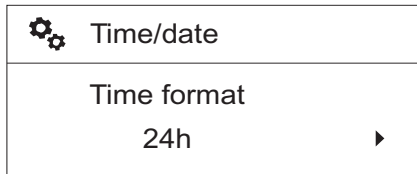

V1137908

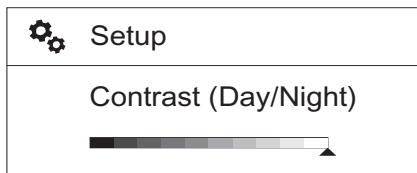
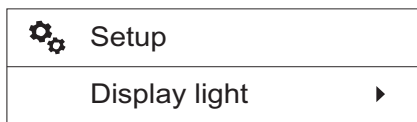

V1137909

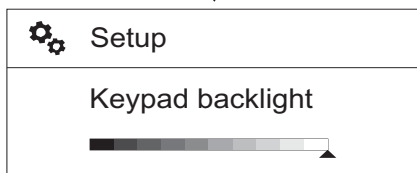
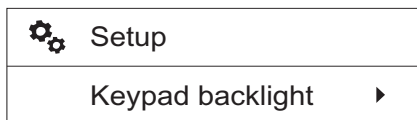

V1137910

- 4 **Time format:** The items "24h" and "AM/PM" decide how the IC (Instrument Cluster) describes the time, 24-hour-system or 12-hour-system.
- Select the preferred format using the arrow buttons.
 - Save the selected item using the SELECT button. Use the ESC button to cancel without saving.

Display light

This is for changing the contrast of the IC (Instrument Cluster). The contrast is independently adjustable for day and night.

- When adjusting the "Contrast(Day)", the machine's work lights should be turned off.
- When adjusting the "Contrast(Night)", the machine's work lights should be turned on.
- The adjusting bar in the screen is controlled with the arrow buttons and the value is set with the SELECT button. Use the ESC button to cancel without saving.

Keypad backlight

The brightness of the keypad backlight is changed by the adjustment.

The adjusting bar in the screen is controlled with the arrow buttons and the value is set with the SELECT button. Use the ESC button to cancel without saving.

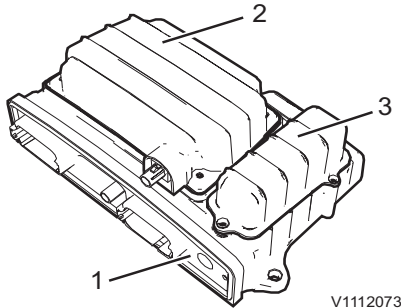

CareTrack unit
1 WECU
2 Satellite modem
3 Back-up battery

CareTrack with anti-theft

CareTrack with anti-theft (optional equipment)

CareTrack with anti-theft function works by WECU, web portal, Volvo's service tool (Tech Tool), GPMECU1, and IC (Instrument Cluster). The anti-theft function is to immobilize the machine according to the following conditions.

- Wrong code alarm
- Geofence broken
- Timefence broken
- System tampered
- Machine movement
- Battery power lost
- Remote immobilization
- No coverage
- ECU tampered

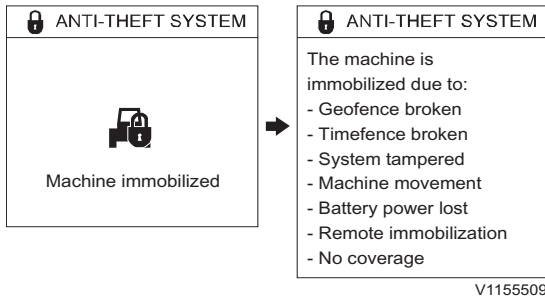

Machine immobilized information

This screen is to warn the operator when the machine is immobilized. To get more information about the message on the screen, press the SELECT button. To go back to the previous screen, press the ESC button.

Wrong code alarm

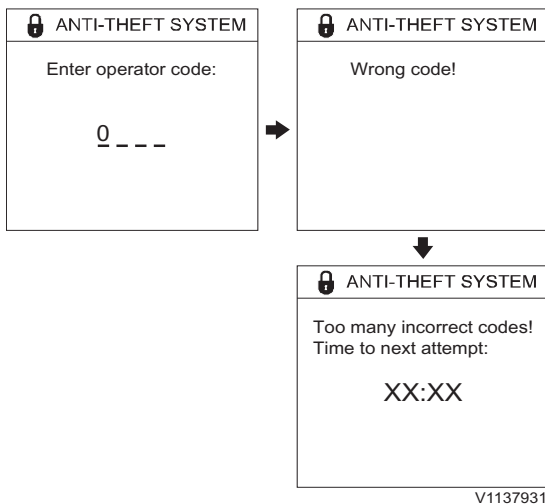

- When the machine is turned on, the authorization code display is shown if the anti-theft system is selected as an optional equipment. Wrong code display appears on the IC when the operator or machine owner has entered the wrong code. After 3 inputs of an incorrect code, the authorization will be limited for 5 minutes and a wrong code alarm will send to the CareTrack portal. The default code lock's delay time is 2 minutes and it can be changed with Volvo's service tool.

Enter operator code
Wrong code
Too many incorrect codes
Time to next attempt

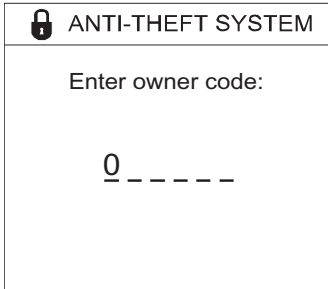

V1137932

Enter owner code

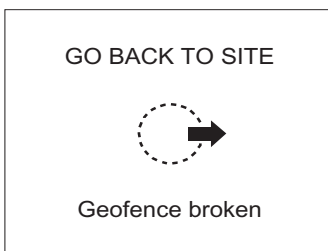

V1137933

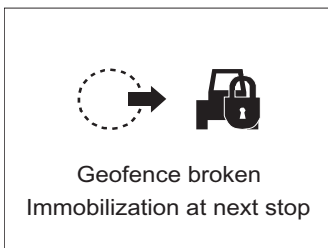

V1137934

NOTE!

When the delay time is shown, press and hold the SELECT button to enter the owner code.

- There are 3 levels for authorizing machine operation.
 - Level 1: This is the operator code with 4 digits which are set by the machine owner in IC menu or CareTrack portal.
 - Level 2: This is a machine owner PIN code with 6 digits which are set using Volvo's service tool.
 - Level 3: This is a one-time code with 8 digits which are obtained from the CareTrack portal.

Geofence broken

- When the machine owner activates a geofence in the CareTrack portal and the machine is outside the geofence, the geofence broken message will appear on the IC.

- When the machine owner activates a geofence and configures automatic immobilization in the CareTrack portal and the machine is outside the geofence, the geofence broken warning message will appear on the IC and the machine is immobilized at the next stop.
- WECU sends the warning message to the CareTrack portal.
- The warning condition is revoked when the machine is inside the geofence.

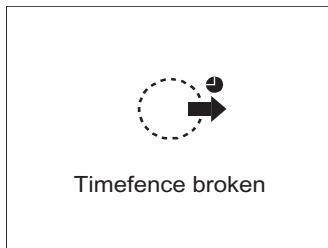

V1137935



V1137936

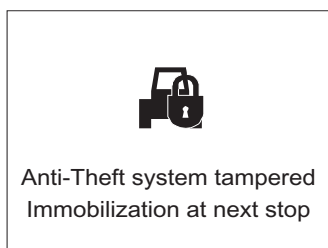

V1155538

Timefence broken

- When the machine owner activates a timefence in the CareTrack portal and the machine is outside the timefence, the timefence broken message appears on the IC.

- When the machine owner activates a timefence and configures automatic immobilization in the CareTrack portal and the machine is outside the timefence, the timefence broken warning message appears on the IC and the machine is immobilized at the next stop.
- WECU sends the warning message to the CareTrack portal.
- The warning condition is revoked when the machine is inside the timefence.

System tampered

- GPS tampered
 - If the machine lost GPS antenna cable connection, the GPMECU1 informs the operator with the warning message on the IC and activates machine immobilization.
- GSM/3G tampered
 - If someone cuts the GSM/3G antenna, the GPMECU1 informs the operator with the warning message on the IC and activates machine immobilization.
- Open box detection
 - If someone tries to open the WECU enclosure, the GPMECU1 informs the operator with the warning message on the IC and activates machine immobilization.
- SIM card tampered
 - If someone removes or changes the SIM card, the GPMECU1 informs the operator with the warning message on the IC and activates machine immobilization.

NOTE!

WECU sends the warning message to the CareTrack portal.



V1139556

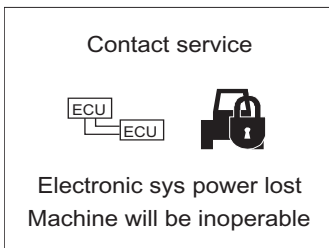

V1137938

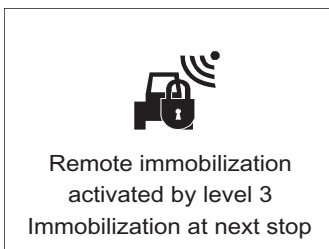

V1137939



V1137940

Machine movement

- If the machine moves 100 metres without its own power, the WECU detects the machine movement and the machine will be immobilized and WECU sends the warning message to the CareTrack portal.
- After the machine has been immobilized, the warning message will appear on the IC before the authorization code display.
- The machine owner or dealer can mobilize (de-immobilize) the machine with codes for Level 2 and Level 3.

Battery power lost

- If the WECU is disconnected from battery power cable or detects the battery supply voltage lower than 8 V, the WECU operates on its own internal battery.
- The GPMECU1 activates machine immobilization and the red warning message will appear on the IC.
- WECU sends the warning message to the CareTrack portal.
- The warning condition is revoked when the trigger has disappeared.

Remote immobilization

- If dealer (level 3 code owner) requests machine immobilization in the CareTrack portal, the remote immobilization warning message will appear on the IC and the machine is immobilized at the next stop.
- If machine owner requests machine immobilization in the CareTrack portal, the remote immobilization warning message will appear on the IC and the machine is immobilized at the next stop.

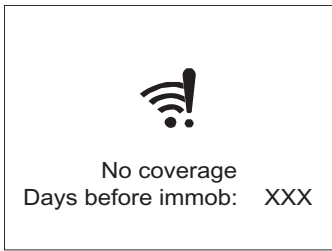

V1139554



V1137942

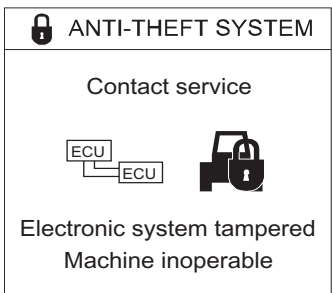

V1139558



V1155510

No coverage

- If the WECU has not been connected to the CareTrack portal for the number of days set by Volvo's service tool, the machine will be immobilized.
- The no coverage days warning will appear at every start with number of remaining days set by Volvo's service tool.
- The active trigger and no coverage counter can be reset using a one-time code or Volvo's service tool.
- If the machine gets a connection to the CareTrack portal, the machine will be mobilized (de-immobilized) and the coverage counter is reset.

ECU tampered

- When the machine is turned on, the WECU and GPMECU1 check the machine serial number of the other ECUs. If the machine's serial number is different, the GPMECU1 prevents machine start immediately and a warning message will appear on the IC.

- If the WECU is disconnected from key on cable and the machine is turned on, the GPMECU1 prevents machine start immediately and a warning message will appear on the IC.
- The warning condition is revoked when the trigger has disappeared.

Anti-theft system, setup menu

This menu is used for setting up the anti-theft system. This menu is divided into two sub-menus as follows.

- 1 **Pin-code menu:** The machine owner's PIN code is required to access this menu. (6 digits)

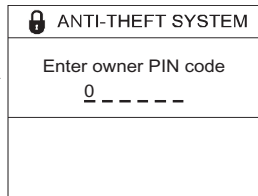
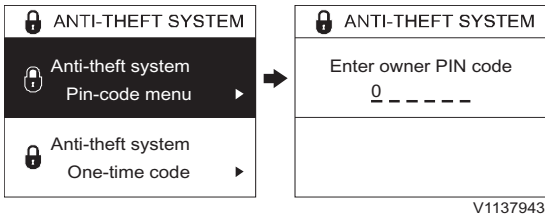

Enter owner PIN code

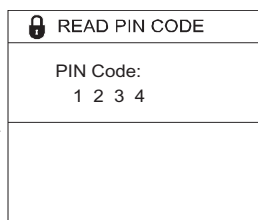
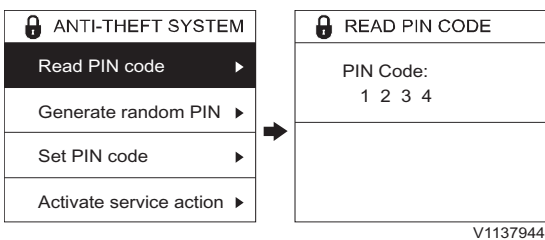

- **Read PIN code:** This sub-menu allows the machine owner to read the current PIN code. (4 digits)

PIN Code

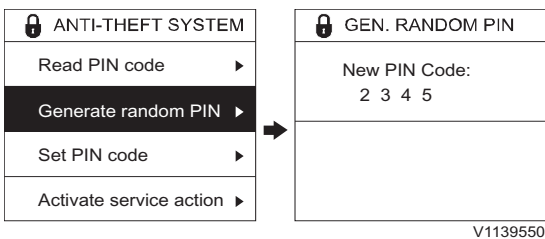

- **Generate random PIN:** This sub-menu allows the machine owner to generate a random PIN code. (4 digits)

New PIN Code

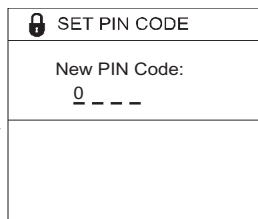
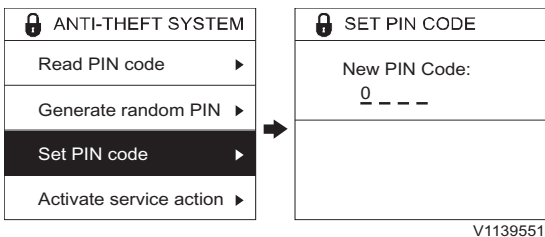

- **Set PIN code:** This sub-menu allows the machine owner to set a preferred PIN code. (4 digits)

New PIN Code

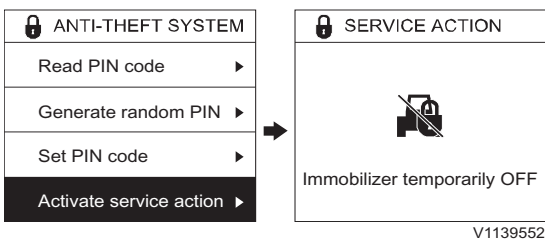

- **Activate service action:** This sub-menu is used for activating service actions such as moving the machine, replacing the machine battery and disconnecting the GPS antenna. This disables the anti-theft system except for remote immobilization, no coverage immobilization and machine serial number check, and the WECU informs the CareTrack portal. The anti-theft system will be activated when the ignition is turned on the next time.

Immobilizer temporarily OFF

76 Instrument panels Display unit

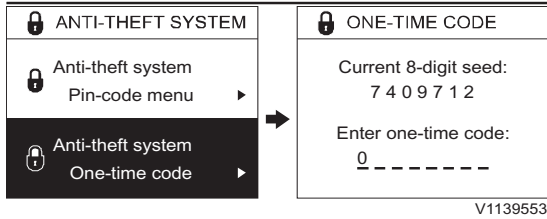

Current 8-digit seed
Enter one-time code

- 2 **One-time code:** This is used for setting a one-time code when the machine is immobilized with level 3 remote immobilization or no coverage warning condition. The machine owner gets the one-time code from the dealer. The dealer gets an 8-digit random code in the CareTrack portal with 8-digit seed (number shown on IC) and machine serial number.

Alarm texts for anti-theft system

Information



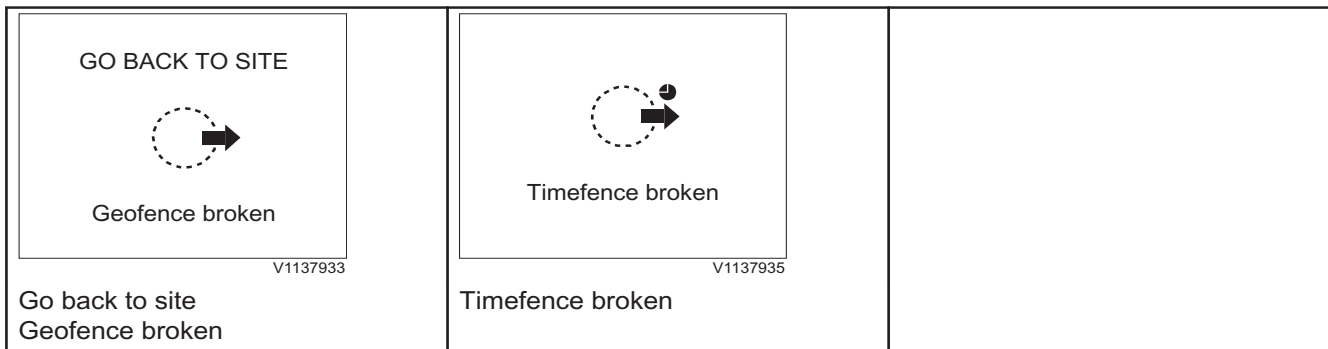



- The blue information symbol is shown.
- The buzzer sounds two times.
- Alarm text is shown for seven seconds and then changes to operating display.





Check





- The amber central warning symbol is shown.
- The buzzer sounds four times.
- Press SELECT button to obtain more information about the malfunction.
- Alarm text is shown until confirmation is performed by pressing ESC button.
- Repair or contact a workshop authorized by Volvo for information.

 <p>Geofence broken Immobilization at next stop</p> <p style="text-align: right;"><small>V1137934</small></p>	 <p>Timefence broken Immobilization at next stop</p> <p style="text-align: right;"><small>V1137936</small></p>	 <p>Anti-Theft system tampered Immobilization at next stop</p> <p style="text-align: right;"><small>V1155538</small></p>
<p>Geofence broken Immobilization at next stop</p>	<p>Timefence broken Immobilization at next stop</p>	<p>Anti-Theft system tampered Immobilization at next stop</p>
 <p>No coverage Days before immob: XXX</p> <p style="text-align: right;"><small>V1139554</small></p>	 <p>No coverage Immobilization at next stop</p> <p style="text-align: right;"><small>V1137942</small></p>	 <p>Remote immobilization activated by level 3 Immobilization at next stop</p> <p style="text-align: right;"><small>V1137939</small></p>
<p>No coverage Days before immob</p>	<p>No coverage Immobilization at next stop</p>	<p>Remote immobilization activated by level 3 Immobilization at next stop</p>
 <p>Remote immobilization activated by owner Immobilization at next stop</p> <p style="text-align: right;"><small>V1137940</small></p>		
<p>Remote immobilization activated by owner Immobilization at next stop</p>		



Warning

- The red central warning symbol is shown.
- The buzzer will sound until the required action has been performed.
- The alarm text will be shown until the required action has been performed.
- Repair or contact a workshop authorized by Volvo for information.

<p> ANTI-THEFT SYSTEM</p> <div style="border: 1px solid black; padding: 10px; text-align: center;">  Machine immobilized <small>V1139556</small> </div> <p>Machine immobilized</p>	<p> ANTI-THEFT SYSTEM</p> <p>The machine is immobilized due to:</p> <ul style="list-style-type: none"> - Geofence broken - Timefence broken - System tampered - Machine movement - Battery power lost - Remote immobilization - No coverage <p style="text-align: right;"><small>V1155511</small></p> <ul style="list-style-type: none"> - Geofence broken - Timefence broken - System tampered - Machine movement - Battery power lost - Remote immobilization - No coverage 	<p> ANTI-THEFT SYSTEM</p> <p>Contact service</p> <div style="border: 1px solid black; padding: 10px; text-align: center;">  Electronic system tampered Machine inoperable <small>V1139558</small> </div> <p>Contact service Electronic system tampered Machine inoperable</p>
<p> ANTI-THEFT SYSTEM</p> <p>Contact service</p> <div style="border: 1px solid black; padding: 10px; text-align: center;">  Anti-Theft system tampered Machine immobilized <small>V1155510</small> </div> <p>Contact service Anti-Theft system tampered Machine immobilized</p>	<p>Contact service</p> <div style="border: 1px solid black; padding: 10px; text-align: center;">  Electronic sys power lost Machine will be inoperable <small>V1137938</small> </div> <p>Contact service Electronic sys power lost Machine will be inoperable</p>	

New X1 work tool
<input checked="" type="radio"/> Push
<input type="radio"/> Toggle
<input type="radio"/> Proportional

V1137912

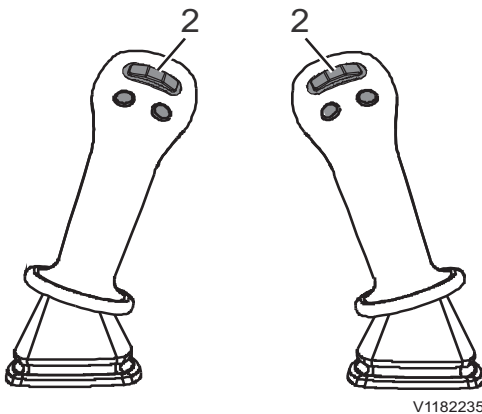

V1182235

Proportional control levers

Control types for X1 and X3 operation

The three control types for X1- and X3-tools are:

- "Push"
- "Toggle"
- "Proportional"

Proportional control levers (Sliding switches)

Push / Toggle

The control of the X3-tool is done by sliding the sliding switch (2) on the left control lever.

The control of the X1-tool is done by sliding the sliding switch (2) on the right control lever.

The controls with proportional switches are similar to the ones with on/off switch, but the switches must be moved to the right or left in order to activate the function.

When "Push" is selected, the actuation will be deactivated when the sliding switch (2) is released.

When "Toggle" is selected the actuation will remain even if the sliding switch (2) is released. To deactivate, move the sliding switch (2) in the same direction again or to the opposite direction.

Proportional

The control of the X1- and X3-tool is proportional to the movement of the sliding switch.

L8-5 control levers

Push / Toggle for sliding switches 1 and 16

The control of the X3-tool and the rotation of the tiltrotator (if installed) is done by sliding the sliding switch (1) on the left control lever.

The control of the X1-tool is done by sliding the sliding switch (16) on the right control lever.

The controls with proportional switches are similar to the ones with on/off switch, but the switches must be moved to the right or left in order to activate the function.

When "Push" is selected, the actuation will be deactivated when the sliding switches (1 or 16) are released.

When "Toggle" is selected the actuation will remain even if the sliding switches (1 or 16) are released. To deactivate, move the sliding switches in the same direction again or to the opposite direction.

Proportional

The control of the X1- and X3-tool is proportional to the movement of the sliding switch.

If a tiltrotator is installed, see page 102 for further details.

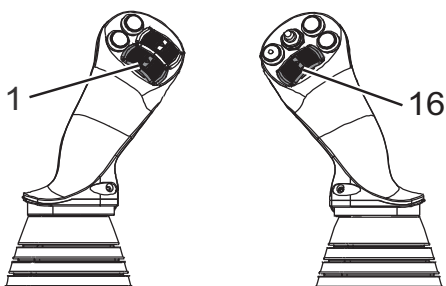

V1182236

L8-5 control levers

80 Instrument panels
Instrument panel, right

Instrument panel, right

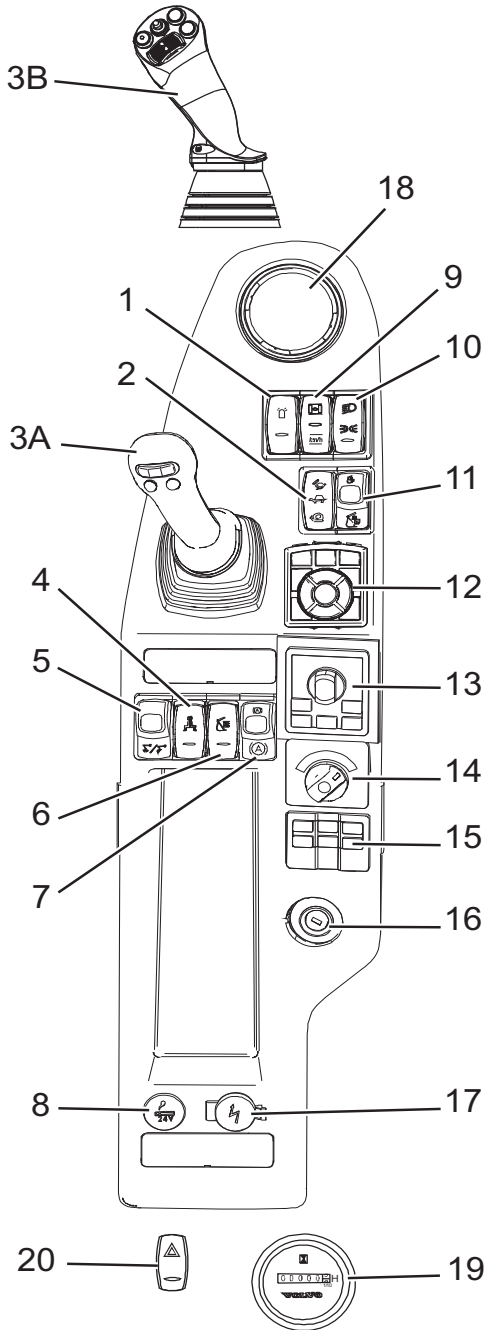

Right instrument panel, standard machine	
1.	Rotating warning beacon switch (optional equipment)
2.	Travel speed selection switch
3A.	Right control lever
3B.	Right control lever (L8-5 control lever)
4.	Comfort Drive Control (CDC) activation switch
5.	Grapple changeover (optional equipment)
6.	Boom suspension system (BSS) (optional equipment)
7.	Electrical digging brake (optional equipment)
8.	Cigarette lighter (optional equipment)
9.	Axle lock and cruise control switch (optional equipment)
10.	Light control switch
11.	Attachment quick coupler switch (optional equipment)
12.	IC (Instrument Cluster) control keypad
13.	Machine control keypad
14.	Mode selector control
15.	Audio remote control
16.	Ignition switch
17.	Power outlet 12V
18.	Drink and cup holder
19.	Hour meter (placed on the right hand panel in the cabin)
20.	Hazard flasher switch (placed under the steering wheel)

V1182508

Right instrument panel, standard machine

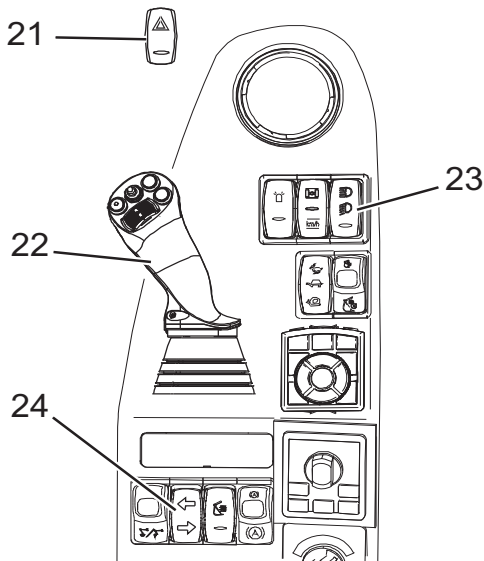

V1185533

Right instrument panel in combination with CDC without steering column

Right instrument panel in combination with Comfort Drive Control (CDC) without steering column (differences to standard instrument panel)	
21.	Hazard flasher switch (placed on the left instrument panel)
22.	Right control lever (L8-5 control lever)
23.	Light control switch
24.	Direction indicator switch

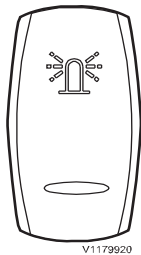

V1179920

1. Rotating warning beacon switch (optional equipment)

Upper end of switch pressed down = rotating warning beacon on.

Lower end of switch pressed down = rotating warning beacon off.

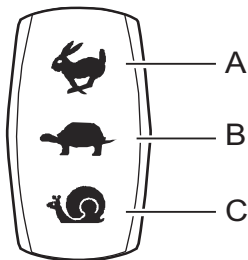

V1147555

2. Travel speed selection switch

A Travelling speed, high

B Travelling speed, low

C Travelling speed, creep

3A. Right control lever

See page 94.

3B. Right control lever (L8-5 control lever)

See page 94.

4. Comfort Drive Control (CDC) activation switch

See page 161.

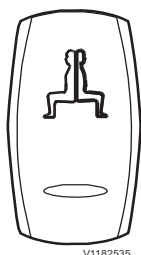

V1182535

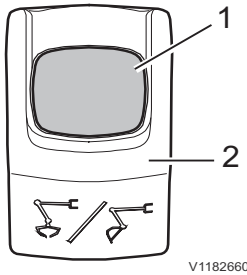

V1182660

5. Grapple changeover (optional equipment)

With the grapple changeover switch the X1 function on the control lever can be switched to bucket function.

NOTE!

This switch is an optional equipment, for details about the control levers see also 94 and following pages.

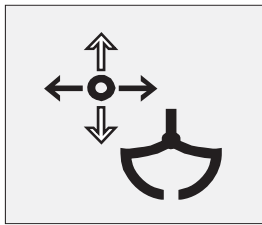

V1182671

Grapple changeover symbol in IC (Instrument Cluster)

- Push the red button (1) of the grapple changeover switch (2) and push down the upper end of this switch simultaneously to activate the grapple changeover function. The switch will be locked in this position.
- With the grapple changeover function activated the control lever function for the bucket (X1 / to the left and to the right) is used to operate the grapple tool. A grapple changeover symbol in the IC (Instrument Cluster) informs that the grapple function is activated.
- To deactivate the grapple changeover function the red button (1) on the switch (2) must be unlocked again.



V1148259

6. Boom suspension system (BSS) (optional equipment)

In order to increase operator comfort and to reduce mechanical stress on the lifting frame and drive line, the machine can be equipped with an optional boom suspension system (BSS). See page 197 for detailed information.

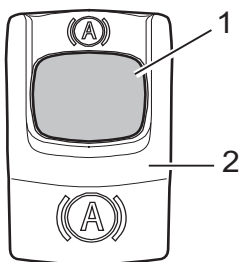

V1148226

7. Electric digging brake (optional equipment)

Upper end of switch pressed down = electric digging brake is selected or deactivated.

Releasing the red locking device (1) by pressing it down and pressing down the upper end of the electrical digging brake switch (2) simultaneously = electrical digging brake is applied, provided that W- or C-mode is selected, the toggle lever locked parallel to the service brake and the machine is standing still.

NOTE!

When the electric digging brake is applied, the axle lock is automatically controlled as well.

For more information, see page 163.

The electric digging brake is released when the engine is running, T-, W- or C-mode is selected, the control lockout lever is in upper position, travel direction is selected and the travel pedal is pressed.

NOTICE

If the brake pressure is too low or if a fault occurs on the electric digging brake, press the upper end of the switch and turn off the engine. Start the engine again and apply the digging brake with the pedal instead.

8. Cigarette lighter (optional equipment)

Press in the lighter and within a few seconds it will return to the original position and ready to use.

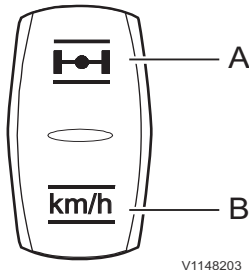
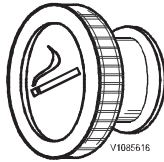

9. Axle lock and cruise control switch (optional equipment)

A Pivot axle lock engaged

B Cruise control engaged

Switch position A: Pivot axle locking

NOTICE

Connect the pivot axle lock when the machine is transported on a trailer, when travelling with a load or when operating in situations where the stabiliser legs or stabiliser blade cannot be used.

Engage the pivot axle lock by pressing down the upper part of this switch (A). Or, if activated, the pivot axle lock can be unlocked with this switch if conditions for automatic lock is not fulfilled any more. See page 150.

Switch position B: Cruise control (optional equipment)

Engage the cruise control by pressing the travel pedal until the desired speed is reached and then press down the lower part of the switch (B) until the cruise control symbol appears in the IC (Instrument Cluster).

Cruise control speed selection:

- Speed up temporarily: Press the travel pedal down while cruise control is engaged, the speed will go back to former value as soon as the travel pedal is released.
- Change the speed permanently: Press button 5 (increase speed) or button 8 (reduce speed) on the control keypad while cruise control is engaged.
- New function added: Cruise control works in travel direction forward, reverse, and in all gears.
Only for models with serial number start: EW160E 322329; EW180E 322114; EW220E 320042

Disengage cruise control by:

- pressing the cruise control switch (lower part of switch)
- pressing the service brake pedal
- lowering the control lockout lever
- changing operation mode, e.g. from W- to C-mode
- changing travel direction
- changing the travelling speed control

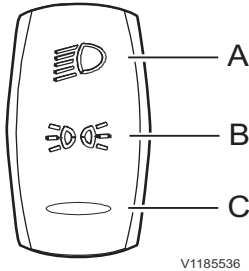

V1185536

10. Light control switch

- A Travel lights
- B Parking lights
- C Lights off

For working light switch see IC (Instrument Cluster) control keypad (position 3).

NOTE!

The parking lights can be switched on also with ignition off. To save the battery it is not recommended to keep them switched on for a long time with ignition off.

11. Attachment quick coupler switch (optional equipment)

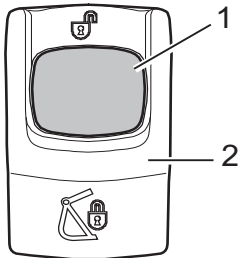

V1148410

Attachment quick coupler switch

! WARNING

Risk of crushing!
Attachments that move unexpectedly can cause injuries.
Make sure people stay out of the working area when connecting or disconnecting attachments.

Initiate the opening of the attachment quick coupler:

Push the red button (1) of the attachment quick coupler switch (2) and push down the upper end of this switch simultaneously to initiate the quick coupler opening. The switch will be locked in this position.

When the attachment quick coupler is initiated, a yellow quick coupler symbol and a check message for unlocked quick coupler will appear in the IC (Instrument Cluster). Additionally the buzzer sounds continuously.

NOTE!

The attachment quick coupler confirmation switch (position 8) on the left instrument panel must be pressed to open the attachment quick coupler. See page 34 for the operation.

Connect the attachment according to the operation description on page 210.

Initiate the closing of the attachment quick coupler:

Press the lower end of the attachment quick coupler switch (2) to close the quick coupler. A yellow quick coupler symbol and a check message for quick coupler locking confirmation will appear in the IC (Instrument Cluster) and the buzzer sound will continue.

NOTE!

When the attachment is correctly locked in the attachment quick coupler, this has to be confirmed by pressing the upper end of the attachment quick coupler confirmation switch (position 8) on the left instrument panel, see page 34.

See page 210 for the complete procedure of the attachment quick coupler operation.

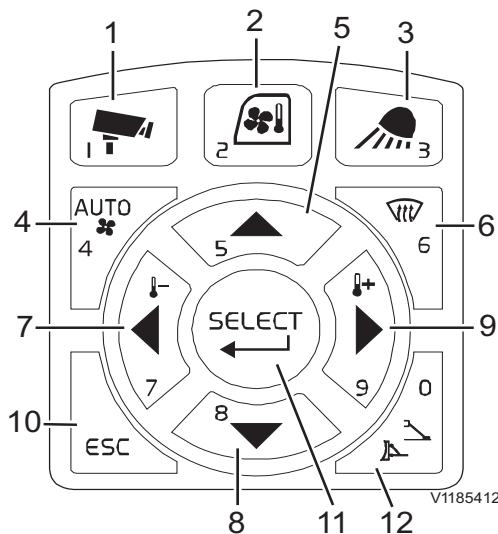

- 1 Camera button
- 2 HVAC control button
- 3 Work lights control button
- 4 HVAC auto-mode select button
- 5 Arrow up button
- 6 Defroster select button
- 7 Arrow left button
- 8 Arrow down button
- 9 Arrow right button
- 10 ESC button
- 11 Select button
- 12 Stabiliser control button

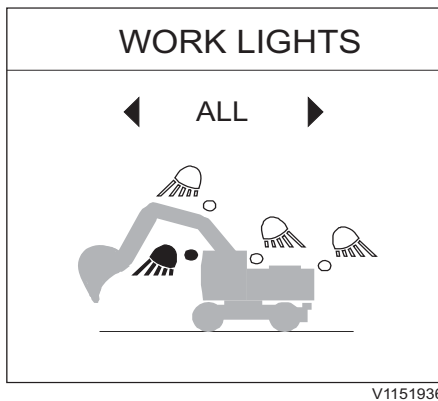

Work light control

12. IC (Instrument Cluster) control keypad

1 Camera button

This button is used to control the camera screen in the IC (Instrument Cluster).

A short press on the camera button shows the camera view with the gauges on top of the screen.

A long press on the camera button will bring up the camera configuration bar.

For detailed information about the camera control, see page 130.

2 HVAC control button

This button is used to control the HVAC system.

For detailed information about this climate control system, see page 119.

3 Work lights control button

This button is used to control the work lights on the boom, counterweight, cab front and cab rear.

A short press on the work lights button switches on/off the work lights with the latest configuration.

If one of the work lights is activated, this button is illuminated.

Work lights menu

A long press on the work lights button opens the work lights menu on the IC (Instrument Cluster).

Press the arrow right or arrow left button to select the work lights on in clockwise / counter-clockwise order.

Press SELECT to turn the selected working light on/off. If the light is on the icon is yellow.

The selection menu can be closed by pressing ESC on the keypad.

The position where you escape the menu is saved.

4 HVAC auto-mode select button

This button is used to control the HVAC system.

See page 119.

5 Arrow up button

Press this button to scroll between items and adjust each segment on the screen.

6 Defroster select button

This button is used to activate the defroster.

See page 119.

7 Arrow left button

Press this button to move the cursor to the left. Also press the button in order to decrease values.

8 Arrow down button

Press this button to scroll between items and adjust each segment on the screen.

9 Arrow right button

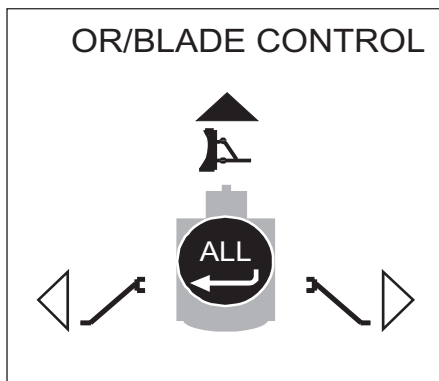

V1151937

Stabiliser control

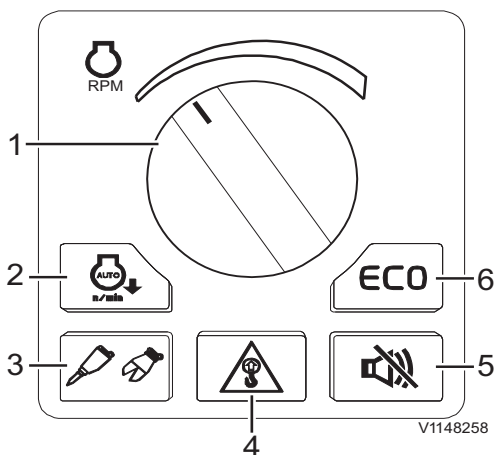

V1148258

- 1 Engine RPM control
- 2 Auto idle button
- 3 Hammer/Shear button
- 4 Overload warning button
- 5 Travel alarm stop button (optional equipment)
- 6 ECO button

Press this button to move the cursor to the right. Also press the button in order to increase values.

10 ESC button

Press this button to go back to the previous screen or to cancel without saving.

The ESC button is also used to turn off the warning light and sound.

11 Select button

Press this button to confirm the item or setup that the user selects.

12 Stabiliser control button

This button is used to select the stabiliser (blade or stabiliser legs, depending on machine configuration) which the operator wants to control with the additional hydraulic lever (position 4 on the left instrument panel) or the optional joystick controlled support function (button 5 on the left control lever), see 34.

A press on the stabiliser control button on the IC control keypad opens the stabiliser control menu in the IC (Instrument Cluster).

Use the arrow buttons to choose the appropriate symbol for blade or stabiliser legs and press SELECT to activate/deactivate the control.

Press ESC to save and close the menu in the IC (Instrument Cluster).

13. Machine control keypad

1 Engine RPM control

This control is used to change the engine speed.

The engine speeds in some positions are different in ECO mode.

- Increase the engine speed by turning the control clockwise.
- Reduce the engine speed by control counter-clockwise.

2 Auto idle button

The Auto idle button activates or deactivates "Auto idle" function.

The engine speed will be reduced automatically to idle in order to reduce fuel consumption if any of control levers, pedals or engine speed control switch are not operated for 5 seconds.

If any one of the above is operated, the engine speed returns to the speed set with the engine speed control switch.

3 Hammer/Shear button

This button is used to activate the hammer/shear function.

For further description of the hammer/shear operation see page 228.

4 Overload warning button

The overload warning button activates or deactivates the "Overload warning" function.

If this function is activated, a symbol in the IC (Instrument Cluster) and an alarm will be generated if the "overload signal" is detected.

- First event of overloading: The pop-up message and the warning indicator will be displayed and a warning alarm sounds. The pop-up message will disappear only when the ESC button is pressed.

- When the event occurs again when operating the machine: A warning alarm sounds and the indicator is shown. When reducing the load, the alarm and indicator will turn off.

5 Travel alarm stop button (optional equipment)

Instrument panels Instrument panel, right

87

The optional "Travel alarm" function is activated automatically whenever the ignition switch is on and the travel pedal is pressed.

It is used to warn people in the surrounding area when the machine is moving.

Depending on the parameter setting, the travel alarm stop button is used to deactivate the "Travel alarm" function directly until the next machine start or to limit it to 10 seconds only each time the travel pedal is pressed.

6 ECO button

ECO function is a mode for fuel economy when working with the machine.

In the ECO mode the pump control works for fuel economy. The button is alight and an ECO symbol is shown on the IC (Instrument Cluster) when activated.

Press the button to deactivate the function and the button light and symbol will turn off.

NOTE!

When the ignition switch is on, ECO mode is always activated automatically.

14. Mode selector control

P = parking mode (parking brake and pivot axle locking are applied).

T = travel mode (public roads).

W = work mode (operating), gives Power Boost pressure during travelling.

C = customer mode (own pump flow settings).

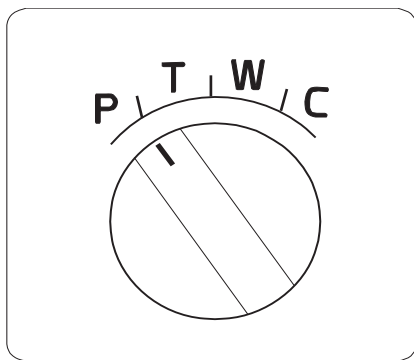

V114824C

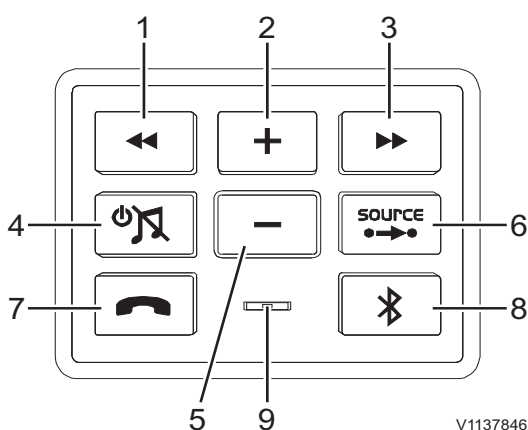

V1137846

- 1 Auto select channel button (downward)
Music select button (backward)
- 2 Volume up button
- 3 Auto-select channel button (upward)
Music select button (forward)
- 4 Power on/off, Mute toggle button
- 5 Volume down button
- 6 Source change button
- 7 Call button (optional equipment)
- 8 Bluetooth button (optional equipment)
- 9 Call mic (optional equipment)

15. Audio remote control

1 Auto-select channel button (downward)

Press the button to search channels automatically. It searches the lower frequencies automatically and stops at a receivable frequency.

Music select button (backward)

It selects the previous song in the play list in your cell phone. When music plays for more than 1 second, it turns back to the start of the song, and if you press the button again, it returns to the previous song.

2 Volume up button

Press the button to increase the volume. Keep pressing it to increase volume gradually.

3 Auto-select channel button (upward)

Press the button to search channels automatically. It searches the higher frequencies automatically and stops at a receivable frequency.

Music select button (forward)

It selects the next song in the play list in your cell phone.

4 Power on/off, Mute toggle button

Press the button to turn On/Off the audio power and to change between Mute/Output.

- Press shortly → Mute/Press shortly → Unmute
- Keep pressing the button → Power off

- 5 **Volume down button**
Press the button to reduce volume. Keep pressing it to reduce the volume gradually.
- 6 **Source change button**
By pressing the FM/AM button, the radio starts and radio modes change (RADIO/USB/AUX).
By pressing this button, you can change the source of music played by the audio system. When you press this button in Bluetooth mode, it changes into Connected Audio Control Mode.
- 7 **Call button (optional equipment)**
Press Bluetooth (connected audio control mode) button for actions related to calls, including calling/ hanging up/ answering/rejecting.
When the phone rings, this button flashes green, and during a conversation, the light is on with fixed green.
 - Not calling: Calling
 - In calling: Hanging-up
 - Flashing (phone ringing): Answering
 - Keep pressing the button while flashing: Rejecting
 - Call function of the button above calls the previous number
- 8 **Bluetooth button (optional equipment)**
By pressing this button, the following functions will work according to the machine's Bluetooth connection status.
 - Not connected: Requesting connection to the previously connected device
 - Connected: Change to Bluetooth mode
 - Keep pressing the button when connected: Disconnect Bluetooth
- 9 **Call mic (optional equipment)**
When you talk using a hands-free device, you can hear a voice with this mic.

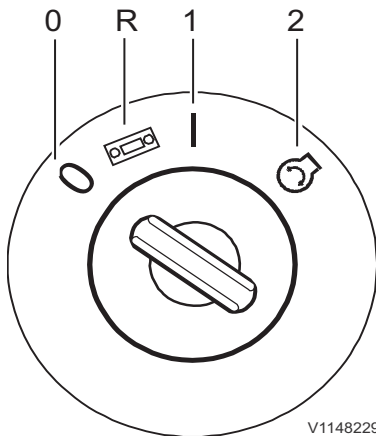

V1148229

Ignition switch

- OFF position (0)
- Radio position (R)
- Operating (preheating) position (1)
- Start position (2)

16. Ignition switch

This ignition switch has four positions. Make sure to activate the battery disconnect switch before trying to start engine.

- 1 **OFF position (0)**
Turn the ignition switch to position (0) to turn off engine.
- 2 **Radio position (R)**
Turn the ignition switch to position (R) to turn on the radio.
- 3 **Operating (preheating) position (1)**
The machine is equipped with an automatic engine preheating system. When the ignition switch is turned to position (1), the vehicle's electronic system will be active, thus activating the automatic engine preheating system.
- 4 **Start position (2)**
When the ignition switch is turned to position (2) the starter motor will be engaged to crank the engine, provided that the battery disconnect switch has been activated. The starter motor will not crank as long as the control lockout lever is in unlocked (up) position. See to page 110 for details on the control lockout lever.

17. Power outlet 12V

The socket is for electrical devices such as a mobile phone charger. Voltage: 12 V. Capacity: 10 A.



V1085711

18. Drink and cup holder

19. Hour meter

(placed on the right hand panel in the cabin)

The hour meter shows the total number of hours the engine has been operating. It is placed on the right hand panel in the cabin. The hour meter is counting if ignition is turned on.

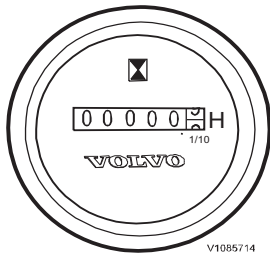

20./21. Hazard flasher switch

(depending on option either placed under the steering wheel or on the left instrument panel)

The hazard flashers work even if the engine is not running. The switch is placed under the steering wheel. On machines without steering column it is placed on the left instrument panel (see page 34).

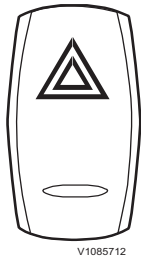

Upper end of switch pressed down = hazard flasher on.

Lower end of switch pressed down = hazard flasher off.

22. Right control lever (L8-5 control lever)

See page 94 for information about the L8-5 control lever functions.

23. Light control switch

(for machines without steering wheel see multi-function lever description on page 97)

A High beam

B Travel lights (with parking lights)

C Lights off

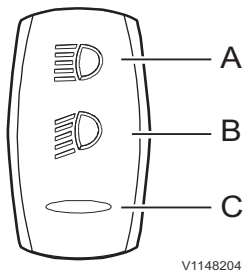

For working light switch see also IC (Instrument Cluster) control keypad (position 3).

NOTE!

The parking lights can be switched on also with ignition off. To save the battery it is not recommended to keep them switched on for a long time with ignition off.

24. Direction indicator switch

(for machines without steering wheel see multi-function lever description on page 97)

A Direction indicator left

B Direction indicator right

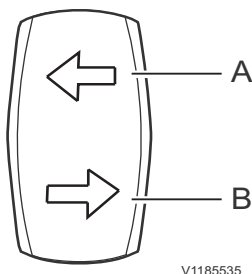

Instrument panel, rear

Instrument panel, rear

- 1 **Audio system (Radio)**
See page 126.
- 2 **Service socket**
This socket is for Volvo's service tools (MATRIS and Tech Tool)
- 3 **Auxiliary heater (optional equipment)**
See page 132.

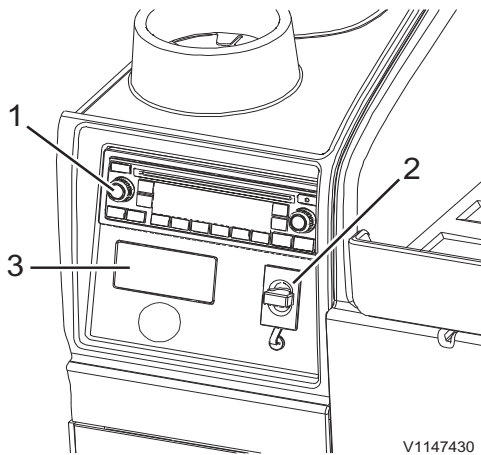

Instrument panel, rear

Other controls Controls

Controls

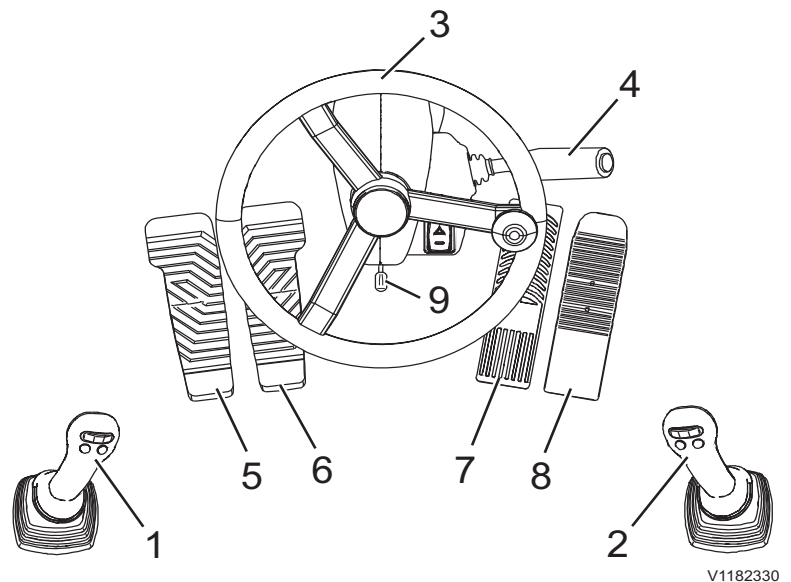

1.	Left control lever
2.	Right control lever
3.	Steering wheel (optional equipment: machine without steering column)
4.	Multi-function lever (not existing on machines without steering column)
5.	Pedal for X1 (optional equipment)
6.	Pedal for offset boom (optional equipment)
7.	Service brake pedal
8.	Travel pedal
9.	Steering wheel adjustment (optional equipment: machine without steering column)

1. Left control lever

See detailed description starting on page 94.

2. Right control lever

See detailed description starting on page 94.

3. Steering wheel

(optional equipment: machine without steering column)

The machine can be steered with the steering wheel or with the control levers if it is equipped with the Comfort Drive Control (CDC) option.

If the machine does not have a steering wheel it can only be steered with the control levers with Comfort Drive Control (CDC) option.

For more information about operating the machine with Comfort Drive Control (CDC) option, see page 161.

NOTE!

When the steered wheels are not at the front in the direction of travel, the machine will steer in the opposite direction.

4. Multi-function lever

(not existing on machines without steering column)

On the multi-function lever there are controls for direction indicators, windscreen wiper, windscreen washer, headlight dipper and horn.

If the machine does not have a steering column the functions of the multi-function levers are on the control levers and the instrument panels, see page 33.

Direction indicators

- Lever moved forwards = Left direction indicators
- Lever moved rearwards = Right direction indicators

Headlight

- Switch between high and low beams by pulling the lever to stop close to the steering wheel. The travel lights are switched on with the light switch on the right instrument panel, see page 80.
- Flash the headlights by pulling the lever lightly closer to the steering wheel.

Windscreen wiper

- Turn the lever to put the windscreen wiper in the required position.
Position (A) = Off position
Position (B) = Intermittent wiping 1
Position (C) = Intermittent wiping 2
Position (D) = Continuous wiping

Windscreen washer

- Push the lever in towards the steering wheel to start the washer and turn the lever to select continuous wiping.

Horn

- Press the button to sound the horn.

- ⏏ D
- ⏏ C
- ⏏ B
- ⏏ A

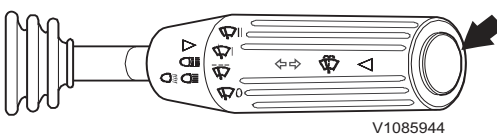
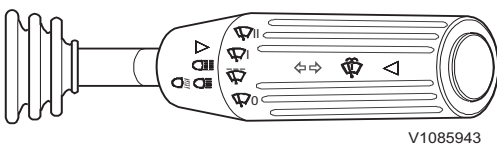

5. Pedal for X1 (optional equipment)

For detailed information about X1 see page 99 and 79.

6. Pedal for offset boom (optional equipment)

For operating offset boom, see page 227 and 227.

7. Service brake pedal with toggle lever for brake lock (digging brake)

The service brake acts on all wheels and is operated with the service brake pedal.

The digging brake consists of a foot-operated, spring-loaded toggle lever on the service brake pedal. If the service brake pedal is pressed down fully, the toggle lever engages the lock pin.

For a description of the digging brake function, see page 163.



7. Electric digging brake (optional equipment)

For a description of the electric digging brake function, see page 163.

NOTICE

If the brake pressure is too low or if a fault occurs on the electric digging brake, press the upper end of the switch and turn off the engine. Start the engine again and apply the digging brake with the pedal instead.

8. Travel pedal

The speed is controlled with the travel pedal.

9. Steering wheel adjustment

(optional equipment: machine without steering column)

! WARNING

Risk of fatal accidents.

Adjusting the steering wheel while operating could cause a loss of machine control.

Always stop the machine before adjusting the steering wheel.

When digging, the steering wheel can be moved toward the window so that it is out of the way of the operator.

- 1 Depress the pedal.
- 2 Adjust the steering wheel and release the pedal.

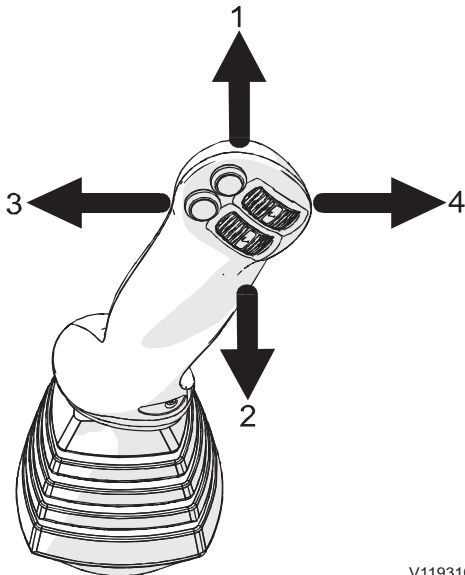

V1193100

Left control lever

- 1 Dipper arm out
- 2 Dipper arm in
- 3 Swing superstructure left
- 4 Swing superstructure right

Control levers, description

The standard machine control pattern is **SAE (ISO)**. With the pattern changer (optional equipment) this can be changed to **BHL**, see below.

1. Left control lever with SAE (ISO)

This lever is used to swing the superstructure and operate the dipper arm.

Combined movements are obtained if the control lever is moved to positions between the ordinary positions. For example, moving the lever to position 6, see below, results in dipper arm in and superstructure swing to the left.

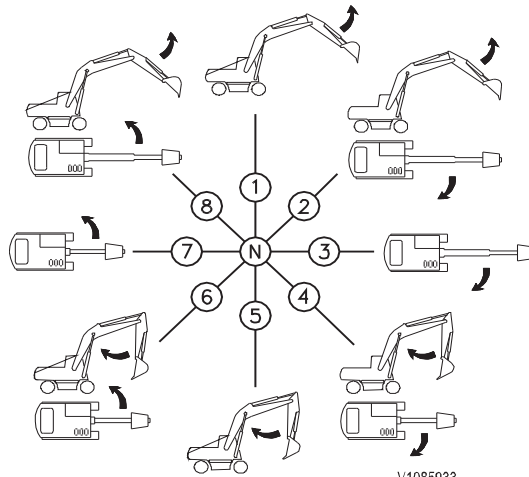

V1085933

N Neutral (superstructure and dipper arm in neutral position)

- 1. Dipper arm out
- 2. Dipper arm out and swing superstructure right
- 3. Swing superstructure right
- 4. Dipper arm in and swing superstructure right
- 5. Dipper arm in
- 6. Dipper arm in and swing superstructure left
- 7. Swing superstructure left
- 8. Dipper arm out and swing superstructure left

Swing brake

Brake the swing movement by moving the control lever to the neutral position.

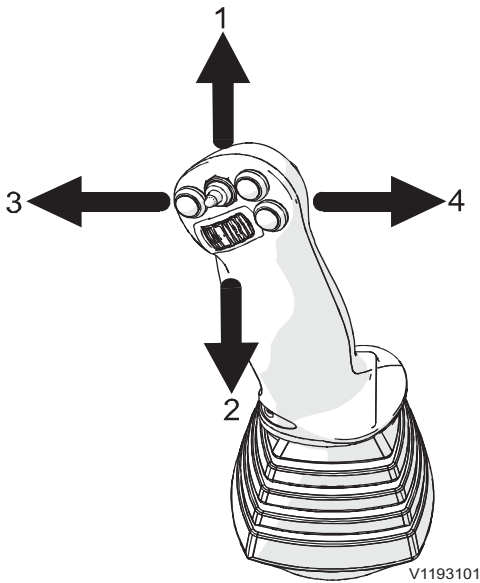

- Right control lever
- 1 Lower boom
 - 2 Raise boom
 - 3 Bucket in
 - 4 Bucket out

2. Right control lever with SAE (ISO)

This lever is used for operating the boom and bucket. Combined movements are obtained if the control lever is moved to positions between the ordinary positions. For example, moving the lever to position 6, see below, results in raised boom and bucket in.

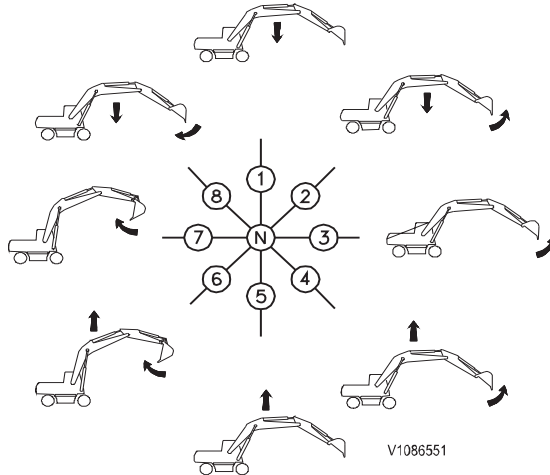

- N Neutral (superstructure and dipper arm in neutral position)
- 1. Lower boom
 - 2. Lower boom and bucket out
 - 3. Bucket out
 - 4. Raise boom and bucket out
 - 5. Raise boom
 - 6. Raise boom and bucket in
 - 7. Bucket in
 - 8. Lower boom and bucket in

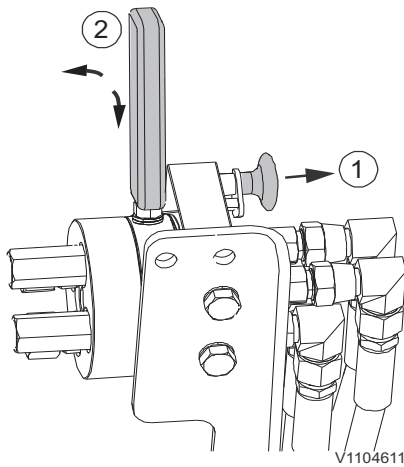

- 1 pull knob
- 2 turn lever back / forward

Changing machine control pattern (optional equipment)

! WARNING

Risk of serious accidents.
Unfamiliar control patterns could cause confusion and accidents resulting in serious injury.

Use extreme caution when using the control levers after changing the control pattern and until you become familiar with the new pattern.

The standard control pattern for the machine control pattern is SAE (ISO). This can be changed to the backhoe loader hydraulic system (BHL) by changing the position of the pattern change valve.

The pattern change valve is located close to the swing motor and is changed as follows:

- 1 Pull knob (1) down and move lever (2) to position B by turning it 45°.
- 2 Release the knob in order to secure the lever after the machine control pattern is set.

Change the control pattern back to SAE (ISO) in the same way.

Lever movements for the backhoe loader system (BHL):

- 1 Dipper arm out
- 2 Swing superstructure right
- 3 Dipper arm in
- 4 Swing superstructure left
- 5 Lower boom
- 6 Bucket out
- 7 Raise boom
- 8 Bucket in
- 9 Hold (superstructure and dipper arm in hold position)

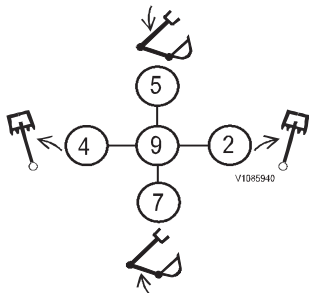

BHL system, left lever

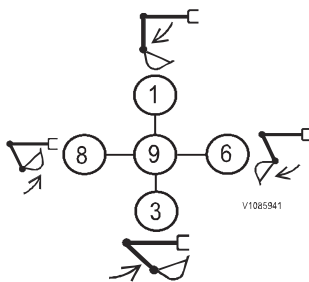

BHL system, right lever

Control levers: buttons and proportional switches

Two different variants of control levers are available from factory, check which control lever variant applies to your machine.

Proportional control levers	
V1182187	
Left control lever	Right control lever
1 Horn	1 Power boost (see page 222)
2 X3 left / right (sliding switch) (see page 98 and 79)	2 X1 left / right (sliding switch) (see page 99 and 79)
3 Shortkey (see page 58) or Two-Piece offset boom (optional equipment) (see page 227)	3 Boom float position (optional equipment) (see page 222)
4 Pivot axle locking (see page 150)	4 Forward / neutral / rearward (travel direction) (see page 160)
5 Joystick controlled support (optional equipment) (see page 34) (not possible in combination with Two-Piece offset boom)	

98 Other controls
Controls

L8-5 control levers

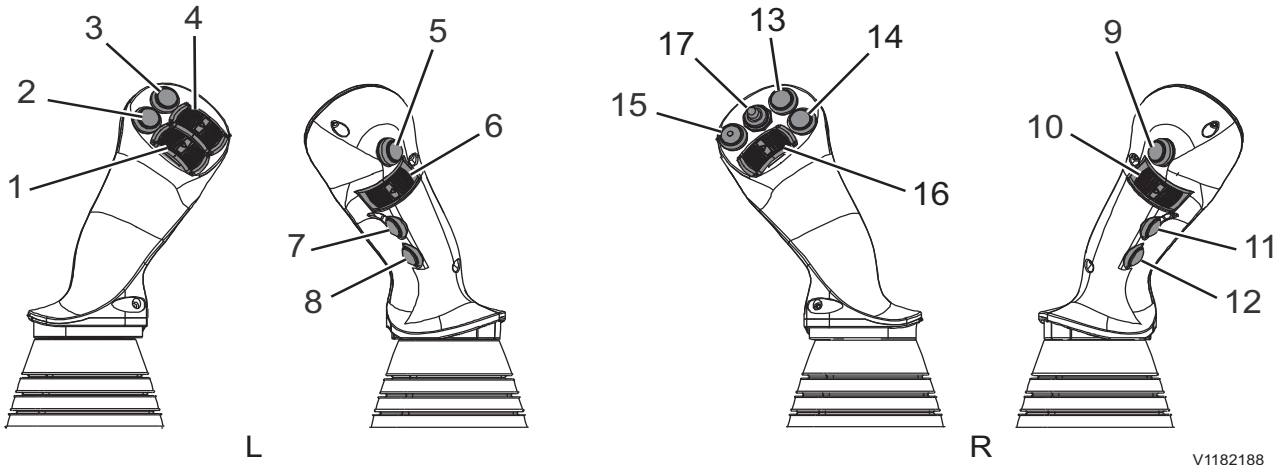

V1182188

Left control lever

Right control lever

1.	X3 left / right / rotate (see page 102 and 79)	9.	Unassigned
2.	Horn	10.	Gripper (optional equipment) (see page 102)
3.	Pivot axle locking (see page 150)	11.	Cabin Up (see page 108) or Steelwrist Option (if Steelwrist is installed)
4.	Additional hydraulics (Volvo X-Function / Steelwrist AUX) (see page 58)	12.	Cabin Down (see page 108) or Steelwrist Option (if Steelwrist is installed)
5.	Joystick controlled support (optional equipment) (see page 34) (not in combination with Two-Piece offset boom)	13.	Float position (see page 222)
6.	CDC (optional equipment) (see page 161)	14.	Shortkey (see page 58) or Two-Piece offset boom (optional equipment) (see page 227)
7.	Unassigned	15.	Power boost (see page 222)
8.	Unassigned	16.	X1 left / right / tilt (see page 102 and 79)
		17.	Forward / neutral / rearward (travel direction) (see page 160)

X3 control, description

The X3 function is used to control attachment tools with a lower limited oil flow.

The oil flow for the X3 function can be set in the IC (Instrument Cluster), see page 58.

The function is controlled by the left control lever.

There are three control types (push, toggle or proportional) which can be selected in the IC (Instrument Cluster), see page 79.

For the hydraulic pressure/flow specifications and for the connection port specifications, see 350



X1 and X3 direction can be changed, for more information, see 58 and the following chapters:

- X1 work tool / Change X1 direction
- X3 operation / Change X3 direction

X1 control, description

This function is for controlling the X1 flow according to the X1 flow setting value of the IC (Instrument Cluster), see page 58.

X1 flow control is used for special equipment such as hydraulic hammer (breaker) or hydraulic shear.

The function is controlled by the right control lever.

There are three control types (push, toggle or proportional) which can be selected in the IC (Instrument Cluster), see page 79.

The X1 function can also be controlled by the optional X1 pedal, see page 91.

Other controls
100 Controls

Table. Quick overview X1 and X3 control

X1, X3 controls and connection ports on dipper arm - factory settings			
1	Proportional joystick, left	5	L8-5 Joystick, left
2	Proportional joystick, right	6	L8-5 Joystick, right
3	Slider X3	7	Main control valve (MCV) A-side bottom → A dipper arm left B-side on top → B dipper arm right
4	Slider X1		

Connection ports on dipper arm front left and right

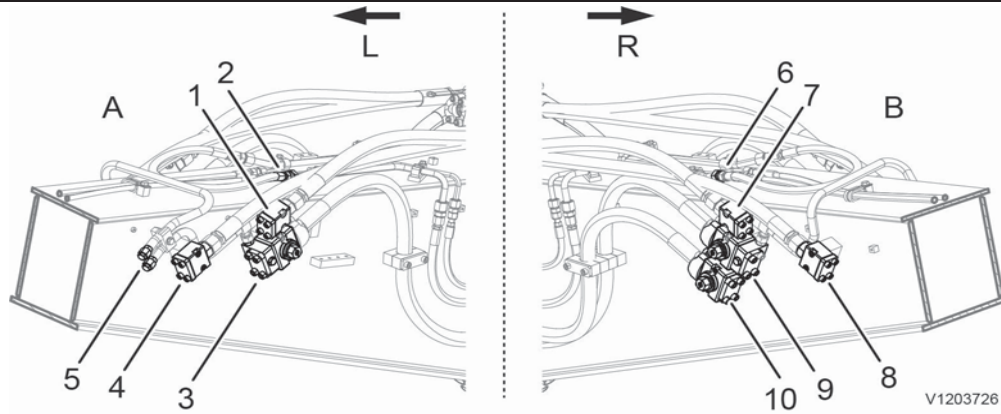

1	Grab piping, left Position for EWR150E, EW160E, EWR170E	6	X3, right
2	X3, left	7	Grab piping, right Position for EWR150E, EW160E, EWR170E
3	X1, left	8	Grab piping, right Position for EW180E, EW220E
4	Grab piping, left Position for EW180E, EW220E	9	X1, right
5	Slope piping, both connections left	10	Hammer return, just one right

For the hydraulic pressure/flow specifications and for the connection port specifications, see 350

X1 and X3 direction can be changed, for more information, see 58 and the following chapters:

- X1 work tool / Change X1 direction
- X3 operation / Change X3 direction

Tiltrotator control system, description
(optional equipment)
Controls

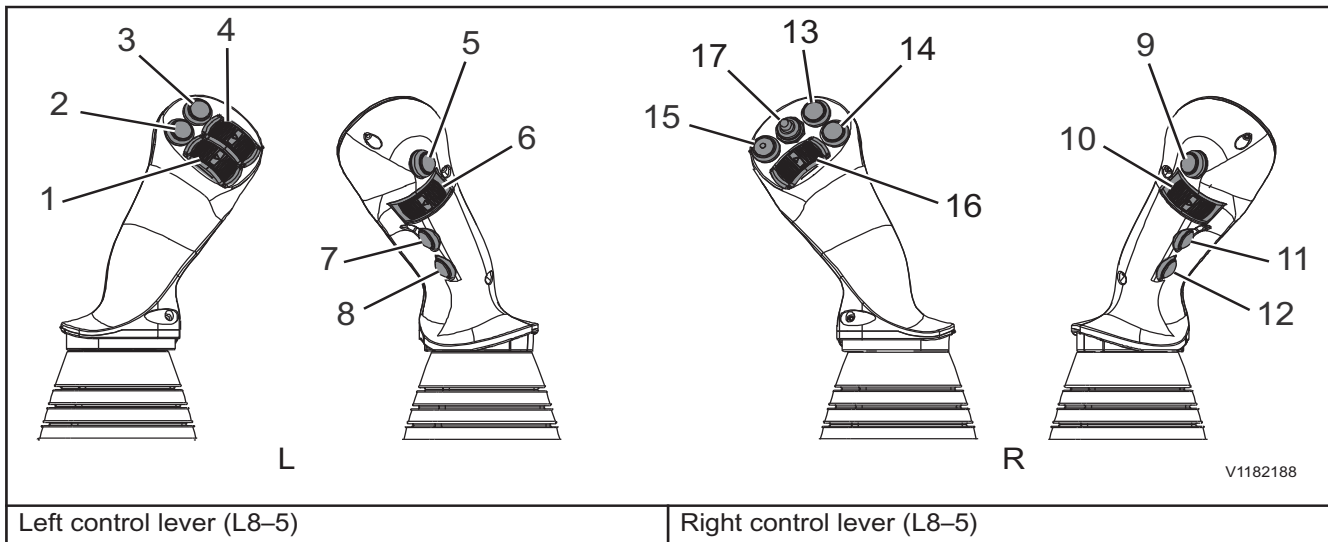

Left control lever (L8-5)

Right control lever (L8-5)

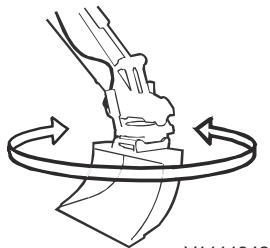

V1111842

Rotation

1 **X3 left / right / rotate**

Drag the slider to the right to turn the tiltrotator clockwise. The more you drag the slider, the faster the attachment will rotate.

The maximum rotation speed for the tiltrotator can be adjusted in the Setup menu, see page 58.

Depending on the setting in the setup menu you can have a Toggle or Push function activated on the button, see page 79.

2 **Horn**

Press the button to sound the horn.

3 **Pivot axle locking**

For details see page 150.

4 **Additional hydraulics (Volvo X-Function / Steelwrist AUX)**

For details about Volvo X-Function see page 58.

The Steelwrist AUX speed to the left and to the right can be adjusted in the Setup menu, see page 58. For details about Steelwrist AUX see Steelwrist manual.

5 **Joystick controlled support (optional equipment)**

For details see page 34.

6 **CDC (optional equipment)**

For details see page 161.

7 **Unassigned**

8 **Unassigned**

9 **Unassigned**

10 **Gripper (optional equipment)**

Drag the slider to the right to open the gripper.

The more the slider is moved the faster the gripper moves.

The maximum gripper speed for the tiltrotator can be adjusted in the Setup menu, see page 58.

11 **Cabin up / Steelwrist Option**

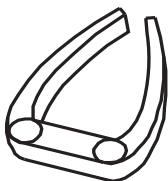

V1111844

Gripper

For details about the Steelwrist Option see Steelwrist manual.

12 Cabin down / Steelwrist Option

For details about the Steelwrist Option see Steelwrist manual.

13 Float position

(For details see page 222.)

14 Shortkey

For details see page 58.

or

Two-piece offset boom (optional equipment)

For details see page 227)

15 Power boost

For details see page 222.

16 X1 left / right / tilt

Drag the slider to the right to lower the right hand side of the attachment. Drag the slider to the left to lower the left hand side of the attachment.

The more the slider is moved, the faster the attachment will tilt.

The maximum tilting speed for the tiltrotator can be adjusted in the Setup menu, see page 58.

Depending on the setting in the setup menu you can have a Toggle or Push function activated on the button, see page 79.

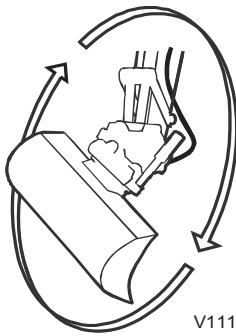

V1111843

Tilting

17 Forward / neutral / rearward travel direction

Use the switch to choose travel direction.

F = Forward (press switch forward)

N = Neutral (switch in middle position)

R = Reverse (move switch backward)



Cab

ROPS (Roll Over Protective Structure)

The cab is designed to ensure minimum crash protection space according to ROPS standard for excavator (ISO12117-2).

The installation of any additional equipments resulting in exceeding maximum tested machine weight on a ROPS identification plate, may void ROPS certification.

Do not jump out of cab if the machine should roll over. Keep stay in seat wearing seat belt.

If any part of the cab's protective structure is affected by plastic deformation or failures, the cab shall be replaced immediately.

NOTE!

Never carry out any unauthorized alterations to the cab, for example lowering the roof height, drilling, welding on brackets for fire extinguisher, radio aerial or other equipment, without first having discussed the alteration with personnel at the Volvo Engineering Department. This department will decide whether the alteration may cause the approval to become void.

It is important that all parties concerned are aware of these regulations.

NOTE!

Machines with an elevating cab are equipped with a TOPS (Tip Over Protective Structure) according to EN474-5 / ISO20474-5 and not with ROPS (Roll Over Protective Structure).



Protection from falling or scattering materials (optional equipment)

Install the necessary protection guards according to working conditions where falling or scattering materials are capable of entering the operator's cab.

FOG (Falling Object Guard) and FOPS (Falling Object Protective Structure)

FOG and FOPS should be adopted when the machine is expected to work in an area where materials are capable of falling to the cab. Especially, in mining applications, FOG shall be adopted.

Safety net

Install safety net to minimize the possibility of breaking windshield when working with a breaker.

The above recommendations are based on standard working, install the necessary additional protection guards in accordance with job site conditions and local government regulations. Contact authorized Volvo dealer to meet local regulations. Any damage can affect the strength of the structure. Contact a qualified service technician for repairing safety structure after damage. Prevent persons from entering or remaining in the dangerous area.

NOTICE

Check the clearance between bucket and cab or spill guard by carefully moving the bucket as close to the cab as possible. The risk of the bucket knocking against the cab is greater if attachment quick coupler is used or if the bucket is provided with lifting eyes.

Other controls
106 Cab

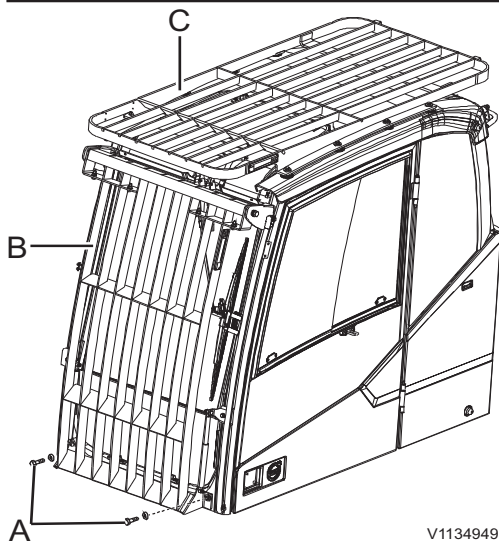

V1134949

- A Screws
- B+C FOG
- C FOPS

Windshield with FOG, cleaning

- 1 Remove the screws (A), and then tilt the FOG.
 - 2 Clean the windshield.
 - 3 Fasten the screws (A) with regulated torque by pushing the FOG. ($48 \pm 4.9 \text{ Nm}$ / $4.9 \pm 0.5 \text{ kgfm}$ / $35.5 \pm 3.6 \text{ lbf ft}$)
- Do not operate the machine while FOG (Falling Object Guard) is tilted. Otherwise, FOG can be damaged by the bucket.

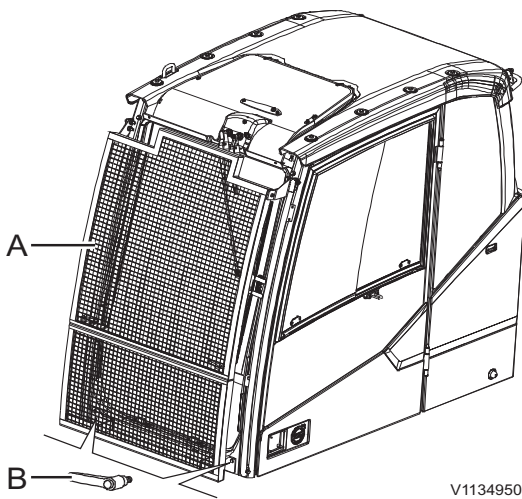

V1134950

- A Safety net
- B Handle

Windshield with safety net, cleaning

- 1 Remove the handle (B), and then take away the safety net.
- 2 Clean the windshield.
- 3 Install the safety net.
- 4 Fasten the handle (B) by pushing the safety net.

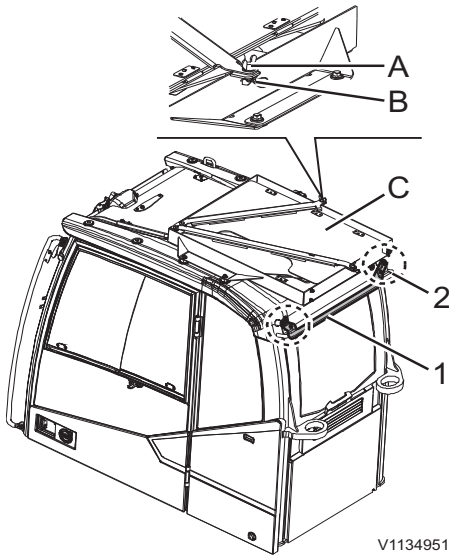

- A Wing nut
- B Pin
- C Covers
- 1 Rear bracket
- 2 Rear handrail

Anti-vandal kit (optional equipment)

NOTE!

Clean mud, grease, oil, and debris from track surface, steps, walkways, and working platforms before installing the anti-vandalism covers.

Anti-vandal covers are stored on the cab.

The wing nut (A) should be tightened and the pin (B) should also be in right position not to be loosen when operating the machine.

Six brackets are needed to install the covers.

- To install the rear bracket (1), remove the rear handrail (2) and reinstall it with rear bracket.
- Install two front brackets (4). For right side of front bracket, remove the front handrail (3) and reinstall it with front bracket.
- Install two lower brackets (5).
- Install the side bracket (6).

Tightening torque:

(1): $2.4 \pm 0.24 \text{ kgf m} / 23.53 \pm 3.9 \text{ Nm} / 17.32 \pm 2.9 \text{ lbf ft}$

(2): $8.7 \pm 0.9 \text{ kgf m} / 85.31 \pm 8.8 \text{ Nm} / 62.8 \pm 6.4 \text{ lbf ft}$

(3),(4),(5): $4.9 \pm 0.5 \text{ kgf m} / 48.05 \pm 4.9 \text{ Nm} / 35.37 \pm 3.6 \text{ lbf ft}$

(6): $1.0 \pm 0.1 \text{ kgf m} / 10 \pm 1 \text{ Nm} / 7.2 \pm 0.7 \text{ lbf ft}$

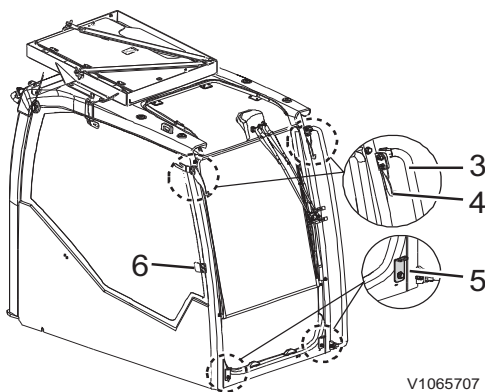

- 3 Front handrail
- 4 Front brackets
- 5 Lower brackets
- 6 Side bracket

NOTE!

When storing the covers (C), make sure that the locking screws do not cause interference between covers.

Elevating cab (optional equipment)

NOTE!

For work with elevating cab, the ground under the machine needs to be flat, hard and horizontal. The maximum ground slope must not exceed 7.5%.

For the dimensions and the weight of the machine with elevating cab please see page 353.

Safety rules for machines equipped with hydraulic elevating cab

WARNING

Risk of crushing.

A falling cab could cause serious injury or death.

Ensure the cab is adequately supported before entering under the cab.

- Do not go or stay under a raised cab or into the crushing area.
- Keep an eye on the crushing area when lowering the cab to be able to react if a person or an obstruction appears.
- Make sure that the machine will not interfere with objects or vehicles when slewing the superstructure or raising the cab.
- If your machine configuration allows travelling on public roads (in terms of dimension and axle loads) the elevated cabin must be in the lower position.
- During travelling or blade operations, the cab must always be in the lowest position.
- During operation the left side cover of the cooler and the adjacent side cover must be closed.

Lift the elevating cab

- 1 Close the cab door.
- 2 Start the engine.
- 3 Fasten the seat belt.
- 4 Place the control lockout lever in upper position.
- 5 Lift the cab by pressing the button (11) on the right control lever.
 - Lifting is only possible in W- and C-Mode.
 - Lowering is always possible.
- 6 Lower the cab by pressing the button (12) on the right control lever.

NOTE!

The cab can only be moved if the seat belt is fastened.

Emergency lowering

Emergency lowering lever in the cab

The cab can be lowered in emergency with the engine shut down and the ignition key in off position.

- 1 Make sure nobody can be injured by the cab down movement.
- 2 Lift up the rubber mat in the cab.
- 3 Turn the red lever (A) under the rubber mat counter-clockwise. The cab slowly lowers.
- 4 When the cab is completely down, return the lever to the original position, see illustration.

Emergency lowering cab on superstructure

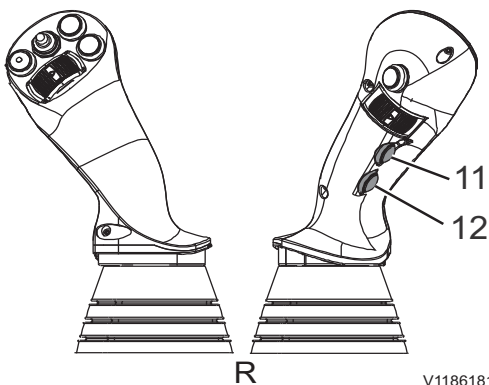

R – Right control lever

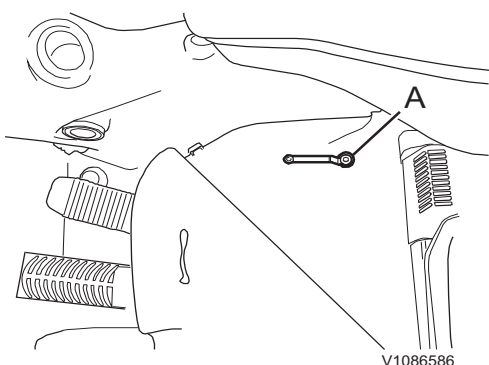

A - Emergency lowering lever in the cab

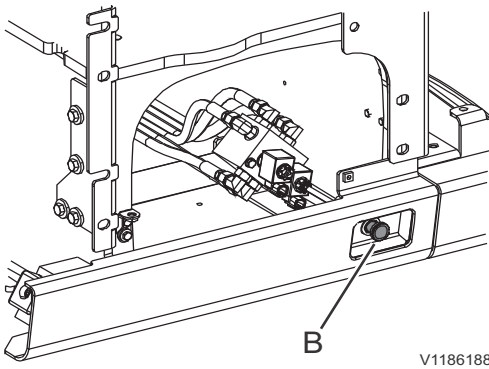

V1186188

B - Red knob on the alternative emergency lowering valve

If the operator in the cab is not able to lower the cab, it is possible to lower the cab from a second person standing on the ground with the alternative emergency lowering valve.

- 1 Stand on the left side of the machine.
- 2 The red knob (B) of the emergency lowering valve is located on the frame below the side cover next to the cab.
- 3 Make sure nobody can be injured by the cab down movement.
- 4 Pull out the red knob (B) and the cab starts lowering.
Hold the red knob until the cab is completely down.

Control lockout system

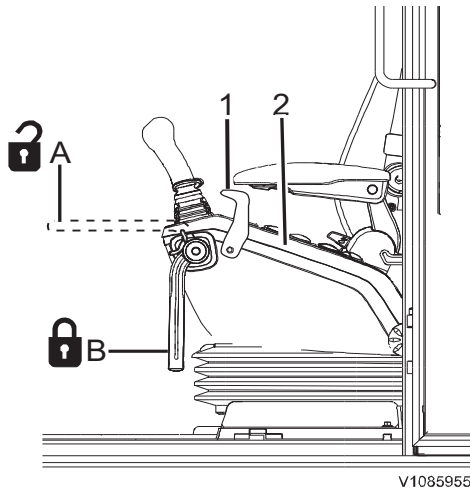

- A Control lockout lever in unlocked position
- B Control lockout lever in locked position
- 1 Release lever
- 2 Left console

WARNING

Risk of serious injury.
Uncontrolled touch of control lever can cause unexpected movement of machine or parts. This could result in serious injury.
Always lock the control lockout lever before starting the engine or before leaving the operator's seat.

Unlocked position (A)

This is the position for working and travelling operations.
When the control lockout lever is in this position, the engine cannot be started.

Locked position (B)

This is the position for locking the control levers and pedals, i.e. the hydraulic system, slew and travel unit. Hereby, inadvertent operation of the machine is prevented, when for example entering or leaving the cab.

When the control lockout lever is in this position, the engine can be started.

Release lever (1) for the control lockout lever and console (2)

- 1 By pulling the release lever, the control lockout lever is put in down position (locked).
- 2 By pulling the release lever a bit further, the console tilts up.

Automatic engine shut down

Automatic engine shut down system is to stop the engine automatically when the machine is not operated for a certain period of time. Default time is set to 5 minutes and can be changed with Volvo's service tool only. Contact a qualified service technician.

Automatic engine shut down conditions:

- Control lockout lever is down.
- DPF regeneration is not in process.

One minute before the engine shut down an info screen will be displayed on the IC (Instrument Cluster) so that engine shut down can be cancelled by pushing the keypad ESC button or moving the control lockout lever up.

To start the engine again after the automatic shut down, the ignition key needs to be turned back to position 0 to shut down the system and then started again.

Operator comfort

Remote welcome lights

(optional equipment — only in combination with LED working lights)

With the remote welcome lights option the working lights on a parked machine can be switched on for a certain time period. It can be used for entering and leaving the machine.

By pressing the switch (1) on the remote control the working lights on the cab and the optional working light on the tank are switched on.

After 110 seconds (factory setting) or if the ignition is switched on they are automatically switched off again.

The remote welcome light function is disabled as long as the ignition is switched on.

NOTE!

The remote control is equipped with a battery under the rear side cover, type 3V CR2032.

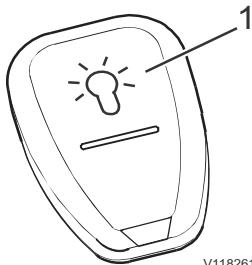

V1182611

Remote control for welcome lights

112 Other controls Operator comfort

Operator seat

The operator seat meets the requirements according to EN ISO7096. The operator seat is designed to provide maximum comfort and reduce vibration to the operator during normal machine operation.

! WARNING

Risk of serious accidents.
Interference with controls while adjusting the operator seat and sudden movements of the seat during the adjustment could cause loss of machine control.

Always stop the engine and put down the control lockout lever to lock the hydraulic functions before adjusting the operator seat and the armrest.

NOTE!

The armrest may have a transport lock. Remove this lock before adjusting the seat and the armrest.

NOTE!

The seat and the armrest must be adjusted in a way that there is no interference with controls.

! CAUTION

Risk of crushing!
Sudden movement of seat may cause crushing injury.
Ensure that all seat adjusting levers are locked into position.

NOTE!

Make sure that no objects are placed within the moving area of the operator seat.

NOTICE

Installation and maintenance of the operator seat may only be carried out by authorised and competent personnel.

NOTE!

The seat is intended for use by one seated occupant only.

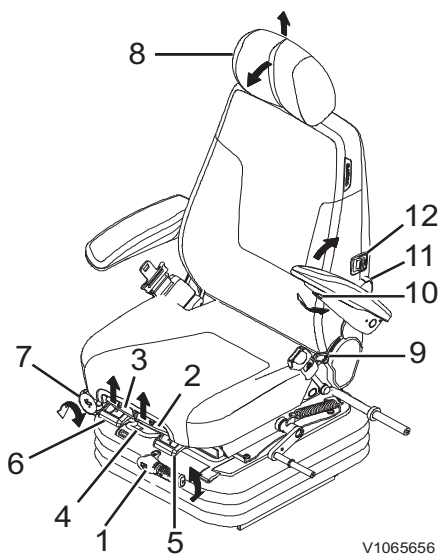

- 1 Weight adjustment
- 2 Fore & aft adjustment, seat cushion
- 3 Angle adjustment, seat cushion
- 4 Horizontal adjustment, top seat
- 5 Horizontal adjustment, top seat and consoles
- 6 X-Isolator adjustment (if installed)
- 7 Height adjustment, consoles
- 8 Headrest adjustment
- 9 Backrest angle adjustment
- 10 Armrest adjustment
- 11 Lumbar support adjustment
- 12 Seat heating switch

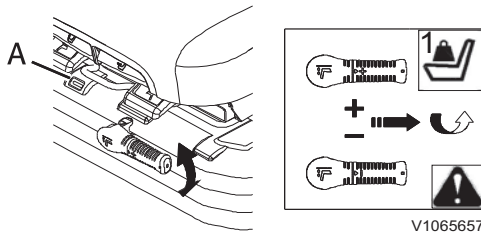

A Ride indicator

Mechanical suspension seat

1 Weight adjustment

Adjust the seat to the drivers weight by turning the weight adjusting handle. The set weight should be within the green zone of the ride indicator.

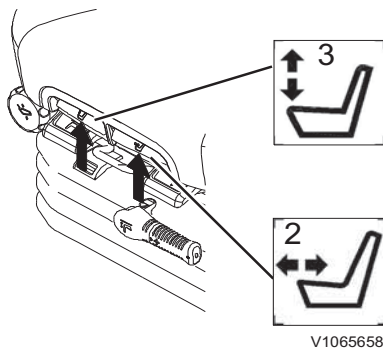

V1065658

2 Fore & aft adjustment, seat cushion

Lift the lever (2) and adjust the seat cushion fore & aft.

3 Angle adjustment, seat cushion

Lift the lever (3) and adjust the angle of the seat cushion. It may be necessary to reduce occupant pressure on the seat cushion when performing this adjustment.

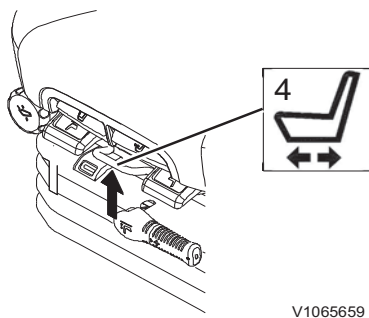

V1065659

4 Horizontal adjustment, top seat

It is possible to move the seat forwards and backwards relative to the control consoles. Lift the handle (4) and move the seat so that the consoles are in the desired position relative to the seat. The locking lever must latch in the desired position. It should not be possible to move the seat into another position when it is locked.

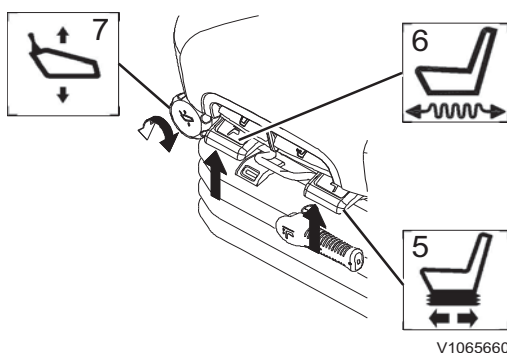

V1065660

5 Horizontal adjustment, top seat and consoles

The seat and the consoles can be adjusted forwards and backwards. Lift the lever (5) and move the seat and consoles to the desired position.

The locking lever must latch in the desired position. It should not be possible to move the seat into another position when it is locked.

6 X-Isolator adjustment (optional)

It is possible to adjust the seat to provide fore and aft isolation. Lift the lever (6) to activate the isolator, push down to deactivate this adjustment.

7 Height adjustment, consoles

Rotate the handle (7) and adjust the height of the control consoles.

Other controls

114 Operator comfort

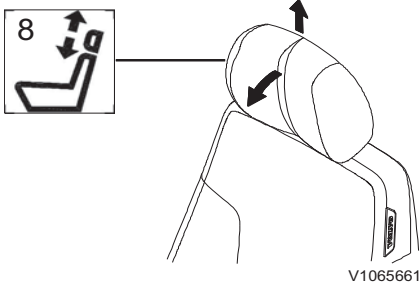

V1065661

8 Headrest adjustment

The headrest can be adjusted for height by pulling up or down. End stops limit the movement. It can be also adjusted for angle by pushing forwards or backwards. End stops limit the movement.

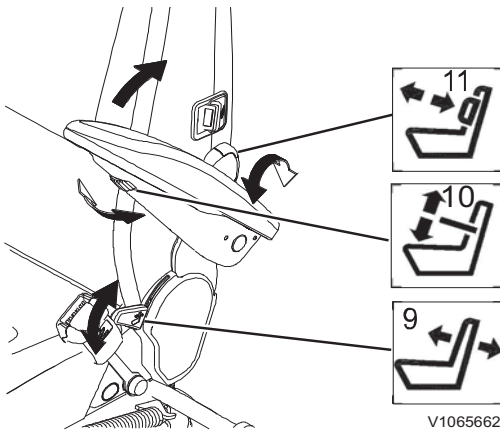

V1065662

9 Backrest angle adjustment

Pulling up the control handle (9) releases the backrest latch. The back of the seat can then be reclined backwards or forwards to the desired position. Releasing the handle allows the backrest to move to a latching position.

The locking lever must latch in the desired position. It should not be possible to move the backrest into another position when it is locked.

10 Armrest adjustment

Inclination of the armrest can be changed by turning the adjustment knob (10) mounted on the underside of the armrest. The armrests can be manually tipped up if required.

11 Lumbar support adjustment

Rotate the knob (11) in the direction of the arrow to increase the amount of lumbar support (five positions). Further rotation in the same direction causes the lumbar support to return to minimum.

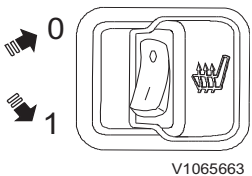

V1065663

12 Seat heating switch (optional equipment)

This is used to warm up the operator seat.

The seat heating will activate when this switch is in position (1) and the temperature is under 26 °C (79 °F). The seat heating stops when the temperature is up to 36 °C (97 °F), and will activate again when the temperature turns down under 26 °C (79 °F) again.

- 0 Seat heating, OFF
- 1 Seat heating, ON

NOTE!

Turn off the seat heating before leaving the operator seat.

Air suspension seat (optional equipment)

The operator seat is also available with air suspension for even better comfort. The adjusting possibilities are the same as for a mechanical suspension seat except adjustment of air suspension.

To adjust air suspension of the seat,

- 1 Turn the ignition key "ON" or start engine.
- 2 Lift operator's weight off the seat.
- 3 Lift and hold the lever (A) until air bag is completely inflated.
- 4 Sit and push down the lever (A) to deflate.
- 5 Stop deflating when seat starts lowering. The set weight should be within the green zone of the ride indicator.

NOTE!

After adjusting the suspension with operator's weight, the suspension height should be in the position within suspension stroke.

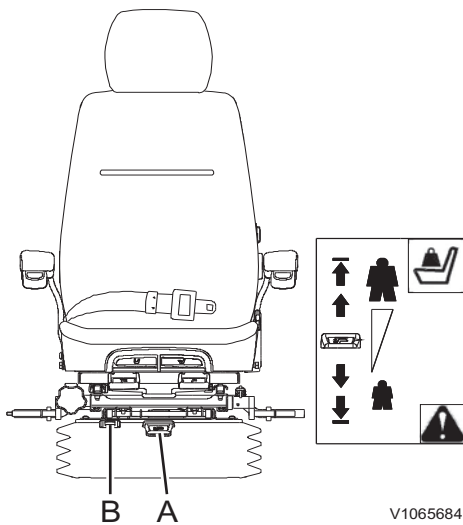

V1065684

- A Adjusting lever
- B Ride indicator

Other controls
116 Operator comfort

Deluxe seat (optional equipment)

The deluxe seat is a high level seat dedicated to provide more comfort to the operator and reduce vibration to the operator during normal machine operation. This seat is equipped with air suspension, fully adjustable armrests, pneumatic adjustable lumbar support and ventilation in cushion and backrest. It meets the requirements according to EN ISO7096.

Seat and armrest adjustment

- 1 Weight adjustment
- 2 Back and forth adjustment, seat cushion
- 3 Angle adjustment, seat cushion
- 4 Horizontal adjustment, top seat
- 5 Horizontal adjustment, top seat and consoles
- 6 Backrest angle adjustment
- 7 Height adjustment, consoles
- 8 Headrest adjustment
- 9 Heating and ventilation switch
- 10 Lumbar support adjustment
- 11 Height adjustment armrest
- 12 Pad adjustment, armrest

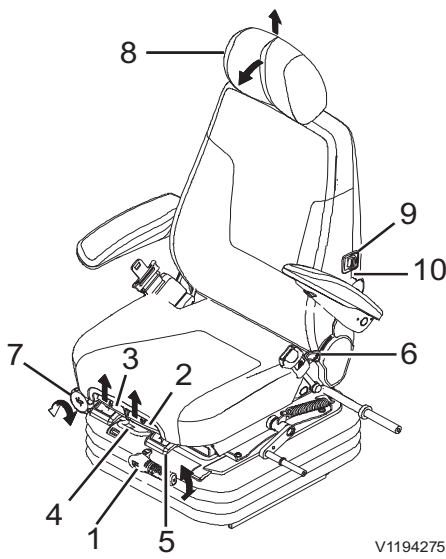

V1194275

Seat adjustment

- 13 Width adjustment

The lateral position of the armrest can be adjusted by turning the armrests around the vertical pins 13.

- 14 Pad angle adjustments

Turn the pad around the 14 to adjust the angle.

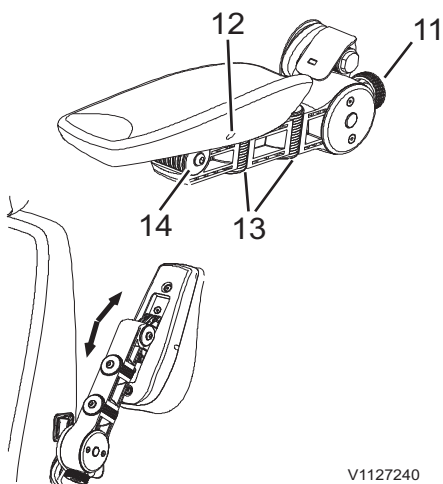

V1127240

Armrest adjustment

NOTE!

Adjusting the armrest height:

- The knob 11 must turn freely without load on it.
- To release the forces on this knob, tilt the armrest up until the knob turns freely.

CAUTION

Risk of crushing!

Sudden movement of seat may cause crushing injury.

Ensure that all seat adjusting levers are locked into position.

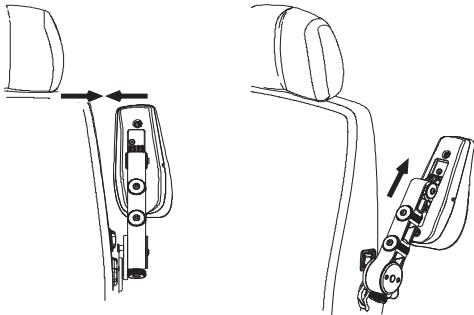

V1127302

Left armrest - adjustment

Left armrest position when entering the cab or leaving it

NOTE!

The left armrest must be adjusted close to the seat to avoid interference with the door handle when closing the door and fully tilted up to not have any interference with the console when entering or leaving the cab.

Special features

Lumbar support

The lumbar support is controlled by the switch position 10. (Depending on the seat version the switch is either on the left or right side.)

By activating the switch, the lumbar support balloon is inflated with air.

NOTE!

Function check: To check the functionality, put your hand on the lumbar support and by acting the switch you can feel the balloon inflating or deflating. When the engine is stopped, you can also hear the compressor when inflating the balloon.

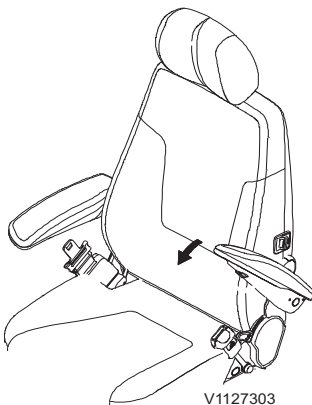

V1127303

Lumbar support

Ventilation / heating

These functions are controlled by the switch position 9. The ventilation and heating are located on the backrest and the cushion.

NOTE!

Function check: To check the ventilation functionality you can turn off the engine, switch on the ignition and listen if you can hear the noise. Another possibility is to switch the ventilation on/off and feel the air flow with a wet hand.

The seat heating has a safety device which stops this function when the ambient temperature has reached a certain level.

NOTE!

Function check: The seat heating can only be checked during cold weather with the same method as the ventilation functionality check.

Other controls
118 Operator comfort

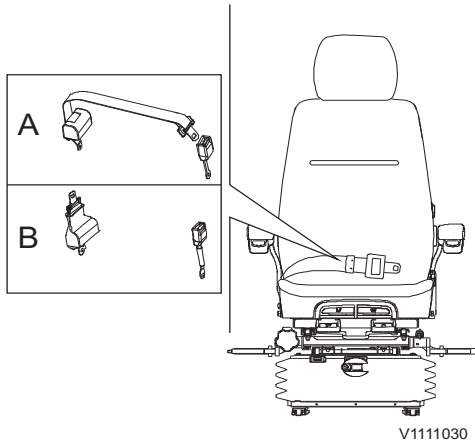

- A Retractable type, 2 inches
- B Retractable type, 3 inches (only available in North America)

Seat belt

! WARNING

Risk of serious injury!
Unexpected machine movement can cause the operator to be ejected from the machine, causing serious injuries.
Operate the machine only while seated in the operator seat with the seat belt fastened.

The seat belt is critical to operator safety and must be worn at all times during machine operation to prevent the operator from being ejected from the cab or the operator platform if the machine rolls over or is involved in an accident. A fastened seat belt also helps the operator to maintain control of the machine if it moves suddenly or in an unexpected way. Failure to wear a seat belt during machine operation could result in serious injury or death. The seat belt is intended for one adult only. Keep the belt rolled up when not in use.

! WARNING

Risk of serious injury or death.
A damaged seat belt could cause serious injury or death.
Check the seat belt and associated parts before start of machine operation.

Check the seat belt and associated parts daily. Ensure mounting hardware is tight. Replace the entire seat belt immediately if there is any wear, the webbing is worn, cut, has loose stitching, the belt is deformed or the seat belt retractor does not work. Replace the seat belt if the machine has been involved in an accident where the belt has been subjected to high strain or loading. Inspect mounting hardware, changes to the belt or its mountings must never be made.

Only clean with warm water, do not use soap or detergent. Let the belt dry while it is fully pulled out before rolling it in.

Volvo Construction Equipment recommends replacing seat belt assemblies every 3 years regardless of appearance.

Climate control system

HVAC system (Heating, Ventilation, Air Conditioning)

The machine can be equipped with different kinds of systems, for example, with air conditioning unit or heater with air conditioning unit. Before operating the system, check the detailed information for your machine.

NOTICE

Risk of damage or malfunction!

If an air conditioning unit is installed:

- Operate it at least once a month during off-season to avoid damage.
- Keep doors and windows closed to avoid waste of energy. Contact a qualified service technician immediately in case of leakage or malfunction.

1. HVAC control button

- Press the button briefly to turn on/off the HVAC system. All settings remain if the system is turned off.
- Press and hold in the button to setup the HVAC system.

NOTE!

Even if the HVAC system is turned off, when CCM (Climate Control Module) gets an auxiliary heater signal, the CCM turns on the cooling fan setting 1st step in manual mode.

2. Arrow up button

This button is used to scroll between items and adjust each segment on the screen.

3. Defroster select button

Press the button to activate the defroster. Fresh air mode is selected automatically. In auto mode, if this button is pressed, mode shall change to manual mode.

NOTE!

After 20 minutes, this setting is automatically returned to the previous mode.

4. Arrow right button

This button is used to scroll between items and adjust each segment on the screen.

Press this button in order to increase the temperature.

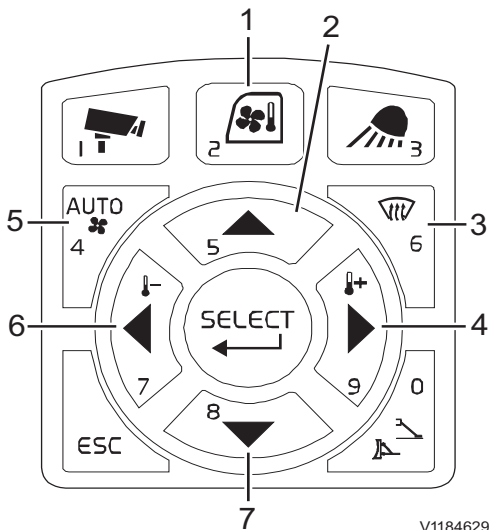

V1184629

IC (Instrument Cluster) control keypad

- 1 HVAC control button
- 2 Arrow up button
- 3 Defroster select button
- 4 Arrow right button
- 5 HVAC auto-mode select button
- 6 Arrow left button
- 7 Arrow down button

120 Other controls
Operator comfort

5. HVAC auto-mode select button

This button is used to select the auto-mode for temperature setting. Required temperature can be changed on the setup menu.

6. Arrow left button

This button is used to scroll between items and adjust each segment on the screen. Press this button in order to decrease the temperature.

7. Arrow down button

This button is used to scroll between items and adjust each segment on the screen.

HVAC setup

Press and hold in the HVAC control button (1) to setup the HVAC system.

A) Climate mode selection

This is for selecting climate mode. (auto, manual, or defrost) Mode selection and fan speed in manual mode are controlled with the arrow left or arrow right button.

B) Temperature control

■ **Auto mode:** Temperature can be adjusted with the arrow left or arrow right button. Default setting value is 22°C (71.6°F) and the setting range is 16°C ~ 32°C (60.8°F ~ 89.6°F). If the temperature sensor in cab fails, auto mode shall turn off.

See page 58 for details on how to change the temperature unit from degrees Centigrade to Fahrenheit.

■ **Manual mode:** Temperature is divided into 8 steps and it can be adjusted with the arrow left or arrow right button. According to the selected step, the temperature will be changed automatically.

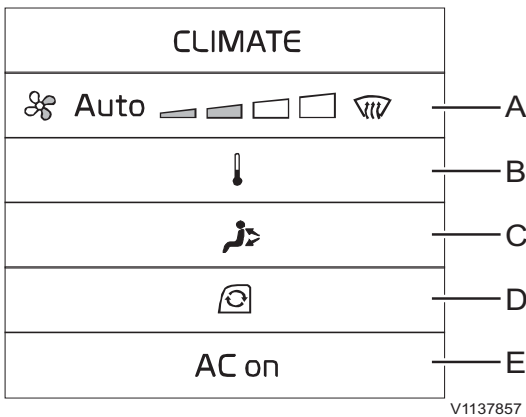

V1137857

HVAC Setup

- A Climate mode selection
- B Temperature control
- C Air flow direction
- D Air flow circulation
- E Air conditioner on/off

C) Air flow direction

This is for selecting the direction of the air flow.

D) Air flow circulation

This is for selecting the circulation of the air flow. (recycle the air inside the cab or draw fresh air from the outside into the cab)
When defrost mode is activated, fresh air mode is selected automatically.

E) Air conditioner on/off

This is for turning the air conditioner on/off.

Windows

Open the upper front window

! WARNING

Risk of serious injury.
Uncontrolled touch of control levers can cause unexpected movement of machine or parts. This could result in serious injury.
Always lock the control lockout lever before opening or closing the window.

- 1 Lower the attachment to the ground and turn off the engine.
- 2 Make sure that the windscreen wiper is hooked onto support (A) to avoid damaging the wiper.
- 3 Incline the steering wheel away from the window.
- 4 Push both buttons (C) in order to unlatch the window from locked position (B) while holding both grips (D), and then pull the window upwards and backwards
- 5 Fix the window in the locked position.

! CAUTION

Risk of crushing.
Crushing injury could be caused when a window slams shut.
Ensure the window is properly locked in any position.

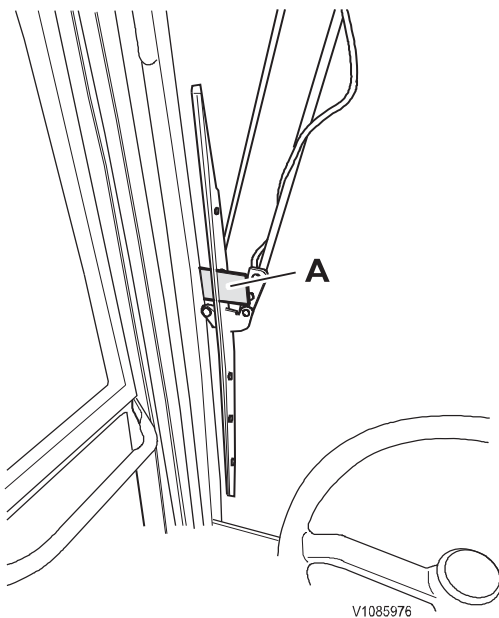

A Windscreen wiper support

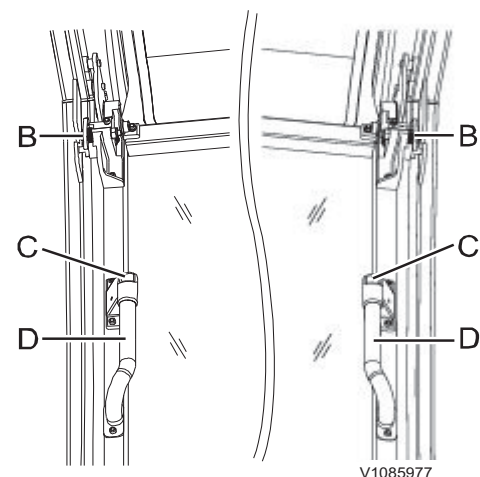

B. Locked position
C. Buttons
D. Grips

Close the upper front window

- 1 Lower the attachment to the ground and turn off the engine.
- 2 Make sure that the windscreen wiper is hooked onto support (A) to avoid damaging the wiper.
- 3 Incline the steering wheel away from the window.
- 4 Push both buttons (C) while holding both grips (D) to move the window out of the locked position.
- 5 Pull the window downwards slowly.
- 6 Fix the window in the locked position.

122 Other controls
Operator comfort

Removing the lower front window

- 1 Open the upper front window, see above.
- 2 Grip the upper part of the lower window with both hands and pull it upwards.
- 3 Store the removed window inside the cab door.

Ensure that the lower window is locked in the storing position. Release the lock by pushing button (B) and turn lock lever (A) to the right simultaneously.

Door

The catch is used for keeping the cab door secure in the open position.

- 1 Open the door completely.
- 2 Make sure it is securely fixed to the catch.

Release the door by pressing lever (B) inside the cab.

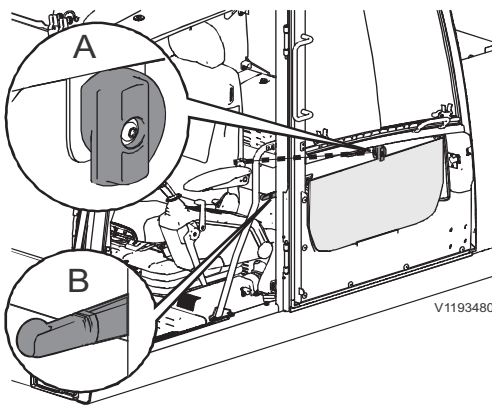

Sun shade

Use the front (1), roof (2) and rear (3) sun shades to protect from the sun light coming in through windows.

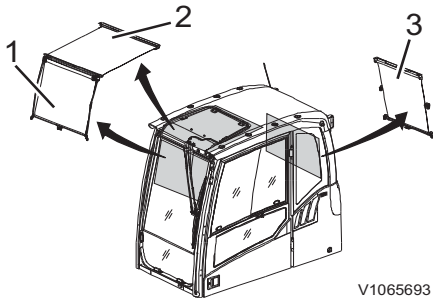

Rain shield

The rain shield (A) prevents rain from falling into the cab when front window is open.

The sunlight protection (B) on the roof reduces incoming light and heat radiation.

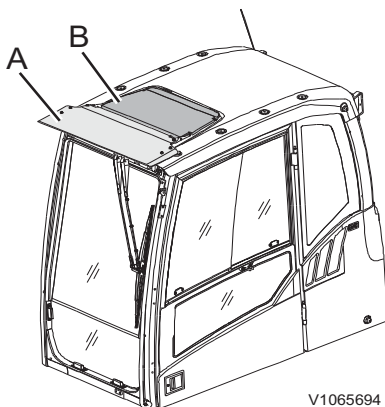

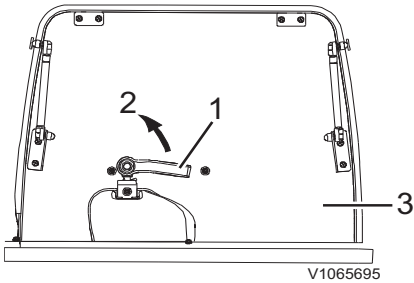

- 1 Handle
- 2 Open direction
- 3 Roof hatch

Roof

Roof hatch, open

- 1 Grip the handle (1) and turn it to open direction (2).
- 2 Open the roof (3).

NOTICE

The roof hatch must be securely locked when transporting.

NOTE!

Cab with fixed roof hatch is provided as an optional equipment. In this case, there is no handle and gas spring.

124 Other controls
Operator comfort

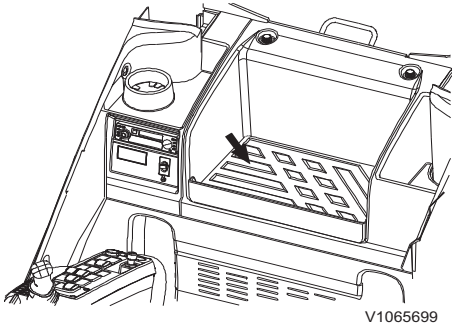

Storage compartment

A storage compartment is located at the rear side of operator seat.

NOTE!

Do not store tools in the storage compartment. This could damage the compartment.

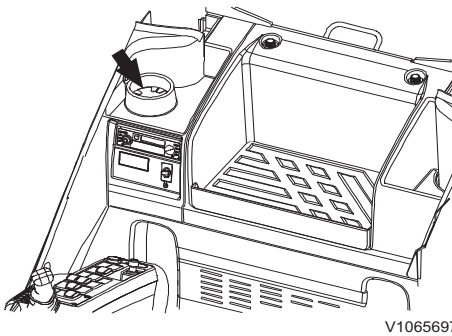

Cup and drink holder

Use the cup and drink holder to hold a soft drink can in place.

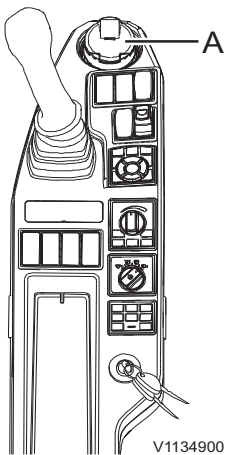

Ashtray (optional equipment)

Pull the top edge of the ashtray (A) in order to open it. Pull the ashtray upward out of the console when cleaning it.

NOTE!

Make sure that you close the ashtray after use in order to prevent any possibility of fire.

NOTE!

The ashtray can be put into the cup and drink holder.

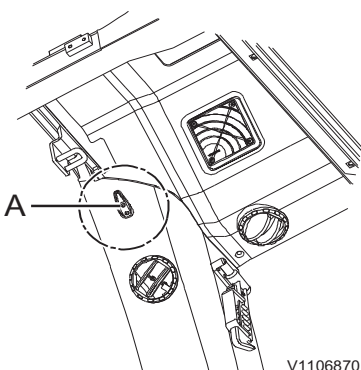

Coat hook

The coat hooks (A) are inside the cab.

NOTE!

Do not hook any item that may obstruct the view of the operator.

Operator's manual, storage

The operator's manual is stored behind the operator seat. Keep the manual in the cab so that it is always at hand.

Fire extinguisher, location

(optional equipment)

Mount fire extinguisher as follows,
Remove two screws inside of caps (1) installed on the rear side in a cab and then install the fire extinguisher.

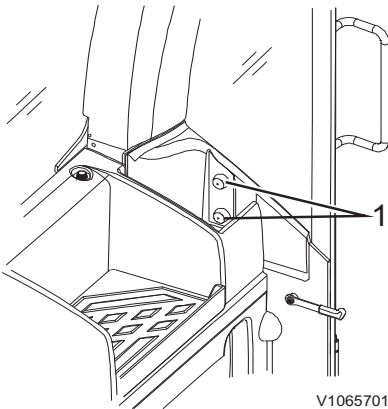

V1065701

Emergency exit

The cab's alternative exit path is the rear window. Regardless of window type, break the glass with the hammer attached to the rear wall inside in the cab.

There is a knife on the hammer for the emergency exit. Cut off the seat belt with the knife, if the buckle cannot be opened.

NOTE!

The hammer must not be removed or used for other purposes than in an emergency situation. A missing hammer must be replaced immediately.

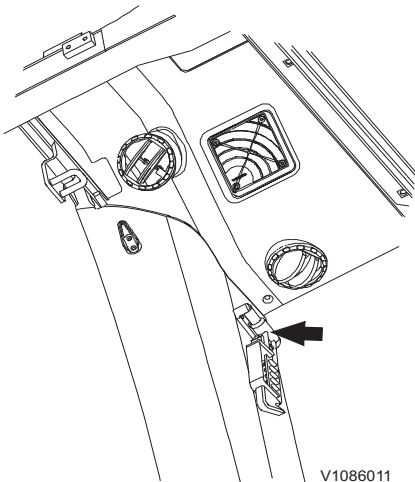

V1086011



Audio system

(optional equipment)

1 Radio setting method by region

- Europe: Press the FM/AM button, and then press preset 6 for 2 seconds.

NOTE!

Setting is completed when "EU" message is shown.

- North America: Press the FM/AM button, and then press preset 4 for 2 seconds.

NOTE!

Setting is completed when "NA" message is shown.

- Others: Press the FM/AM button, and then press preset 5 for 2 seconds.

NOTE!

Setting is completed when "INT" message is shown.

2 Tuning ranges

	Band	Frequency
Europe	FM	87.50 ~ 108 MHz
	AM (MW)	531 ~ 1602 KHz
	LW	153 ~ 279 KHz
North America	FM	87.50 ~ 107.9 MHz
	AM	530 ~ 1710 KHz
Others	FM	87.50 ~ 108 MHz
	AM	531 ~ 1602 KHz

Radio and USB-MP3 Player (with bluetooth)

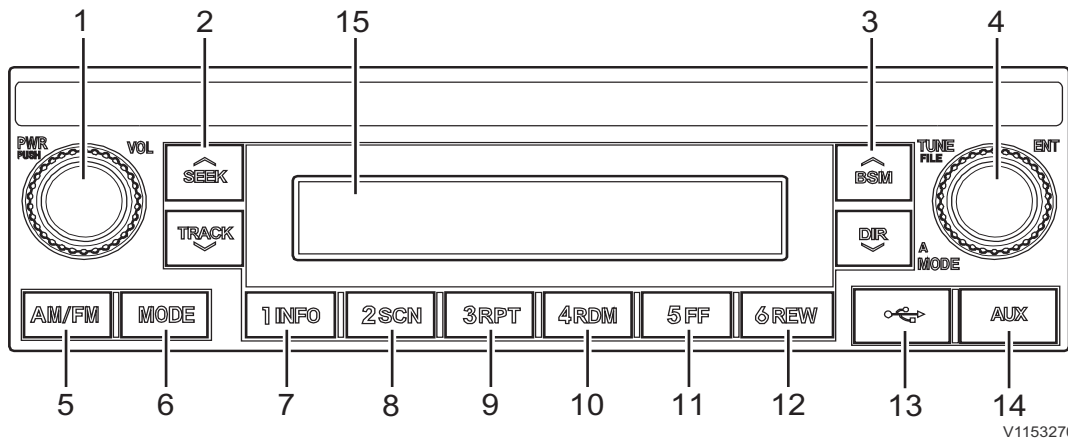

1	Power and Volume	9	Preset 3 / Repeat
2	Seek and Track	10	Preset 4 / Random
3	BSM and DIR	11	Preset 5 / Fast Forward
4	Tune, A mode, and File	12	Preset 6 / Rewind
5	AM / FM	13	USB
6	Mode	14	AUX
7	Preset 1 / Info	15	LCD panel
8	Preset 2 / Scan		

■ Power and Volume setting button (1)

- Power button
Press the power button to turn on the audio system. While the audio is operating, press the button to turn off the power.
- Volume button
Turn the volume button clockwise to increase the volume and counter-clockwise to decrease the volume.

■ SEEK and TRACK button (2)

- Broadcast automatically search button (SEEK / TRACK)
The buttons are used to automatically search for broadcasts, pressing the button will automatically search and stop at a frequency with the best reception.
SEEK: Searches frequencies higher than current frequency
TRACK: Searches frequencies lower than current frequency
- Track up / down button (SEEK / TRACK)
While playing a USB-device, press the SEEK button to play the beginning of the next song.
Press the TRACK button to return to the beginning of the current song. Press the button again to play the beginning of the previous song.

■ BSM and DIR button (3)

- Best Station Memory button (BSM)
Press the BSM button to automatically save frequencies with the best reception in presets (1 INFO ~ 6 REW).
- Directory up / down button (BSM / DIR)
If there are more than 2 folders in the USB-device, pressing the BSM up / DIR down button will move to the previous or next directory.
If there are no folders in the USB-device, then pressing the button will move up / down within the folder in 10 file increments.

■ TUNE, A MODE, and FILE button (4)

- Broadcast manual search button (TUNE)

The button is used to search for frequencies manually, a tune of the SEEK STEP will change the frequency. Turn the button clockwise to increase the frequency and counter-clockwise to decrease the frequency.

- Sound setting button (A MODE)

Press the sound setting (A MODE) button to set sound. Each press of the button will change the sound setting in the following order.

BASS → MIDDLE → TREBLE → BALANCE → FADER → LOUD

After selecting the desired setting, turn the sound setting (A MODE) button clockwise / counter-clockwise to adjust the sound setting value.

- Finding and Playing file (FILE)

While a USB-device is playing, turn the FILE button left / right to find the desired song and press the FILE button to play.

■ **Radio select (AM / FM) button (5)**

- Each press of the AM / FM button will change the radio mode in the following order.

FM1 → FM2 → AM → FM1

■ **MODE select button (6)**

Press the MODE button to change to RADIO / USB / AUX modes.

- USB select button

While playing a different mode, press the MODE button to convert to USB mode. Connecting a USB-device to the audio system will automatically convert to USB mode even if another mode is playing and then songs on the USB-device are played automatically.

- AUX select button

While playing a different mode, press the MODE button to convert to AUX mode. Connecting your portable media player to the audio system will automatically convert to AUX mode even if another mode is playing and then songs on the portable media player are played automatically.

■ **PRESET buttons (7, 8, 9, 10, 11, and 12)**

Select the preset button (7, 8, 9, 10, 11, and 12) to which you want to save the selected frequency. Press and hold the preset button. The frequency will be saved to the preset button to the sound of a beep. The saved frequency number will be displayed on the LCD panel.

■ **INFO button (7)**

Each time the INFO button is pressed, the info on the currently playing song will be displayed in the following order.

File Name → Folder Name → Title Name → Artist Name → Album Name → Play Time

■ **Scan and Directory scan button (8)**

While music is playing, press briefly on the SCN button to scan each song within the current directory for 10 seconds in sequential order.

While music is playing, press and hold the SCN button to scan each song in the USB-device for 10 seconds in sequential order.

■ **Repeat and Directory repeat button (9)**

While music is playing, press briefly on the RPT button to repeat the currently playing song.

Press and hold the RPT button to sequentially repeat all songs within the current directory. (However, for Directory RPT, music files in the USB-device must be saved in directory format.)

■ **Random and Directory random button (10)**



While music is playing, press briefly on the RDM button to randomly play the songs in the current directory.

While music is playing, press and hold the RDM button to randomly play all songs in the USB-device.

■ **Fast forward button (11)**

While a USB is operating, press and hold the FF button to fast-forward the song. When fast-forward is complete, the next song will play from the beginning even if you continue holding the button. Pressing the button briefly will not operate FF.

■ **Rewind button (12)**

While a USB is operating, press and hold the REW button to rewind the song. When rewind is complete, the current song will play from the beginning even if you continue holding the button. Pressing the button briefly will not operate REW.

■ **USB-connector (13)**

It is the connector for direct connection of a USB-device. Connecting a USB-device to the audio system will play the songs on the USB-device.

Charging is not possible with the USB-connector.

NOTE!

When using an external USB-device, make sure to keep the device disconnected and connect only some time after turning on the vehicle's ignition switch. The USB-device may be damaged if the USB-device already is connected when the ignition switch is turned on. (A USB-device is not an electric automotive part.)

■ **AUX-connector (14)**

It is the connector for connecting your portable media player using an AUX cable. AUX cable is not supported.

NOTE!

The device will not operate when playing a format which is not MP3 or WMA file formats.

Other controls
130 Operator comfort

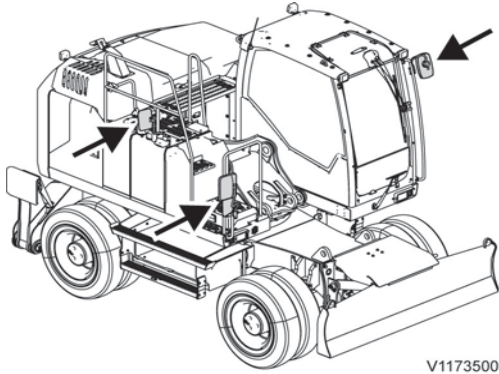

V1173500

Mirrors

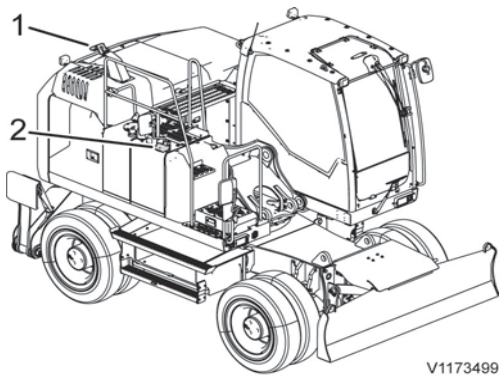

V1173499

Cameras

- 1 Rear view camera
- 2 Side view camera

Vision system

The machine has a lot of equipment for the operator to minimize visibility hazards. Using this equipment, the operator must always have good visibility of the surroundings when operating the machine.

- Mirrors
- Rear view camera
- Side view camera

NOTE!

Any modifications done to the machine that affect the operator's visibility must be verified by a Volvo dealer.

Camera system

The camera screen in the IC (Instrument Cluster) (A) opens by pressing the camera button (B) on the keypad.

The camera button is illuminated when the camera view is displayed.

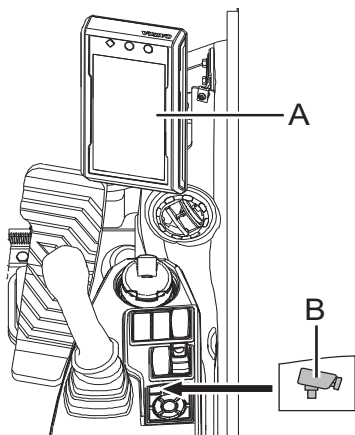

V1151952

- A. IC (Instrument Cluster)
- B. Camera button

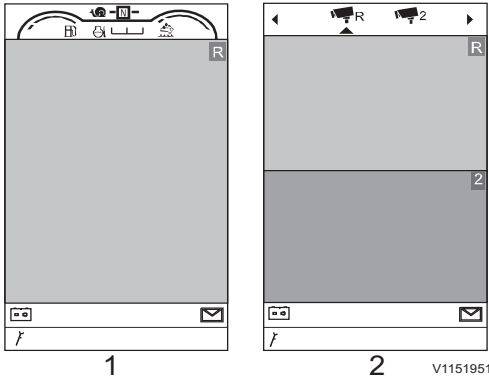

- 1 Camera view with gauges
- 2 Camera view with configuration bar

- **A short press on the camera button shows the camera view with gauges (1):**
This camera view (1) shows the camera screen (depending on the selected configuration) with the fuel level, engine coolant temperature, AdBlue®/DEF level, travel speed, travel direction and the mode.
- **A long press on the camera button shows the camera view with configuration bar (2):**
This camera view (2) shows camera screen with the camera configuration bar on top.
The camera configuration bar is used to show or hide camera views on the IC (Instrument Cluster).
Press the camera button (B) on the keypad to rotate the camera views clockwise.
Select one of the camera icons and press SELECT on the keypad to show or hide this camera view.

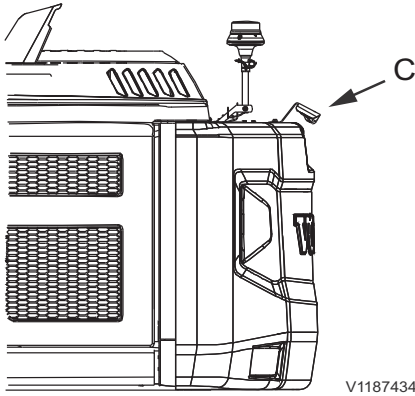

C. Rear view camera

Rear view camera

The rear view camera (C) is installed on top of the counterweight.

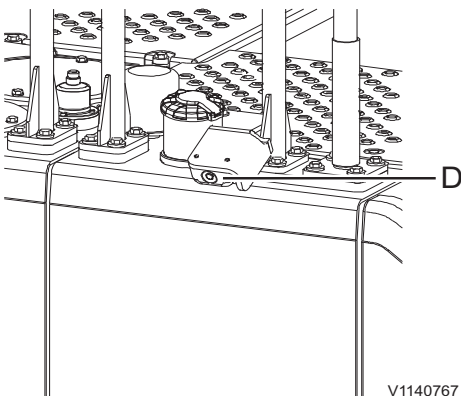

D. Side view camera

Side view camera

The side view camera (D) is installed on the right side of the machine.

132 Other controls
Operator comfort

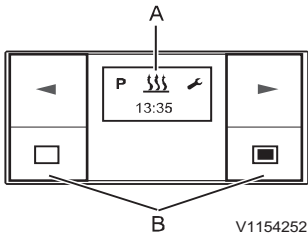

A Display window
B Buttons

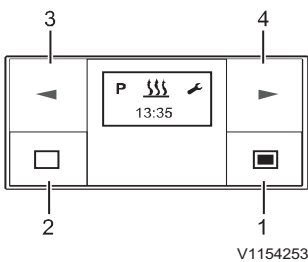

1 Power on / confirm button
2 Power off / cancel / exit setting button
3 Backward button
4 Forward button

CAB auxiliary heater, description

(Optional equipment)

The auxiliary heater timer can be used to make the necessary settings for operation of the heater.

Button functions

If the display is not lit the timer must be activated. SHORTPRESS on one of the four buttons, the start display appears in the display, then continue with the operation or setting.

All functions can be set and, if necessary, changed with only 4 buttons.

1 Power on / confirm button

- SHORTPRESS button
 - if the display shows OFF → Timer On, the start display appears.
 - A selected function is confirmed.
 - Inputs are confirmed.
- LONGPRESS button : The button must be pressed for longer than 2 seconds.
 - The heater is switched on immediately if On or OFF appears in the display.

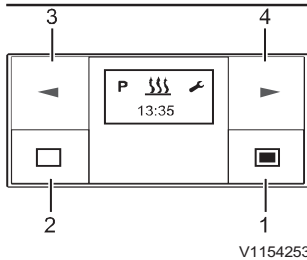

- 1 Power on / confirm button
- 2 Power off / cancel / exit setting button
- 3 Backward button
- 4 Forward button

2 Power off / cancel / exit setting button

■ SHORTPRESS button

- The displayed, activated function is ended, other activated functions are retained.
- With each SHORTPRESS the display changes to a next-higher level up to Timer OFF.
- The start display appears and no function is active: → Timer OFF.
- Timer is in submenu → the setting is exited, already set values are not saved.
- If the display shows OFF → Timer On, the start display appears.

■ LONGPRESS button : The button must be pressed for longer than 2 seconds.

- All functions are ended.
- If the display shows OFF → Timer On, the start display appears.

3 Backward button

- Timer is in the Main menu and the start display appears → in the Menu bar the next, left-hand symbol appears in the middle and flashing.
- Timer is in the submenu → the displayed value is changed (smaller), or the next selection is displayed.
- If the display shows OFF → Timer On, the start display appears.

4 Forward button

- Timer is in the Main menu and the start display appears → in the Menu bar the next, right-hand symbol appears in the middle and flashing.
- Timer is in the submenu → the displayed value is changed (larger), or the next selection is displayed.
- If the display shows OFF → Timer On, the start display appears.

134 Other controls
Operator comfort

Operation and setting/adjustment

Main menu

Menu bar

The following menu items can be selected.

Symbol	Function
	Heating ON / OFF
	Settings
P	Program / Preselection

Status area

If no menu item is activated, the current time is displayed in the status area.

If a menu item is activated (heating, settings or program / preselection), different information is displayed in the status area.

Submenu

In the submenu, the symbol of the selected menu item appears in the middle of the display. The corresponding set value is displayed flashing in the entry area and can be set using the Backward button (3) or Forward button (4) and confirmed with the Confirm button (1).

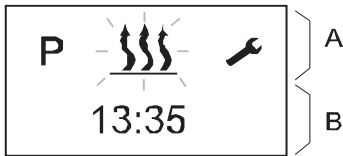

V1154254

Main menu

- A Menu bar
- B Status area



V1154255

Submenu

- A Menu bar : activated function
- B Input area



V1154256



V1154257

Start display after switching ON

if no menu item is activated, the start display appears with a flashing heater symbol in the Menu bar, with the current time in the status area.

Other possible actions are:

- Heating immediately with LONGPRESS button (1).
- Heating on with SHORTPRESS button (1), in addition confirm and set the operating time.
- Select a new menu item.

1 Heating ON / OFF

- Heating immediately with LONGPRESS (without settings)
 - 1 Press the LONGPRESS button (1) for longer than 2 seconds.
 - 2 Screen shows remaining operating time.
 - 3 If LONGPRESS is pressed during heating mode, the display switches to the heating submenu set and set operating time. During heating mode it is possible to switch to another menu item.

Other controls

136 Operator comfort



V1154258

- Heating on with SHORTPRESS and with settings
 - 1 Press the SHORTPRESS button (1) for less than 2 seconds.

NOTE!

The following settings and confirmations (operating time) are always required.

- 2 If necessary, use the BACKWARD or FORWARD button to set the operating time. Press the confirm button (1) to confirm the operating time.

- Heating OFF

- Press the button (2) for longer than 2 seconds. → all active functions are ended.
- Press the button (2) for less than 2 seconds. → heater OFF. After the heating off the start display appears. if the vehicle lighting is off the display lighting goes out after 10 seconds.

The following actions are possible during the heating off display:

- Use the forward or backward button to select a menu item. Press the SHORTPRESS button (2), the start display appears.
- Press the SHORTPRESS button (1), the heating submenu is displayed.

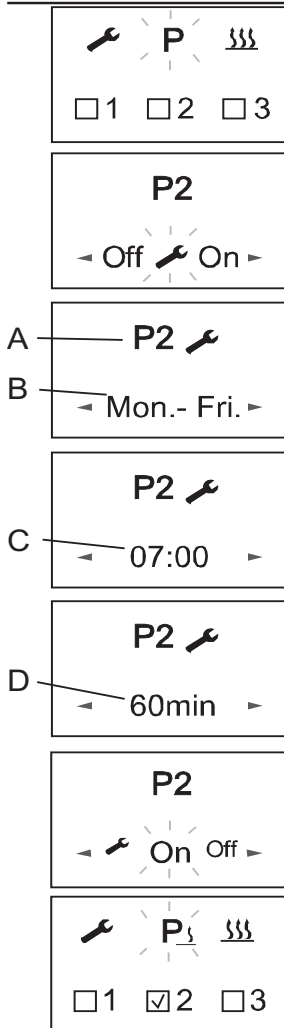

V1154261

- A Preset unit
- B Preset day
- C Departure time
- D Operating time

2 General information on programming the preset time

Timer can be used to program 3 preset times. The 3 preset times can either all take place on one weekday or can be distributed between different weekdays. 3 weekday ranges are available to choose from, these can each be started daily with a preset time.

■ Weekday ranges:

- Day: Once
- Sat-Sun: 2x Heating
- Mon-Fri: 5x Heating
- Mon-Sun: 7x Heating

- If the system is activated with programmed weekday range, all weekdays are worked through consecutively; after that renewed programming is required.
- If the timer with a programmed weekday range Mon – Fri is activated on Wednesday, the heater heats on Thursday and Friday, the heater is not operated on Saturday and Sunday. From Monday to Wednesday of the following week the operation is continued with the set defaults (5x heating). After a weekday range has been worked through renewed programming is required.

■ Departure time operating mode (factory setting)

Under the following conditions the preselected heating mode is not started on the current day.

- The current day and the preselected day are identical.
- The current time lies within the time period, departure time minus operating time.

Example:

Current day / preselected day: Mon

Current time: 06:45

Departure time: 07:00

Operating time: 60 minutes

Duration: 06:00 to 07:00

The current time lies within the time period, the heater is not switched on.

The program will be run during the next week.

■ Program preset times

- 1 Use the backward or forward button to select the Program symbol in the menu bar.
- 2 Confirm the Program menu by pressing the confirm button (1).

If the Program symbol is marked with **P₃**, a or several program memories is/are already activated.

Activated program memories are marked in the display with

a .

Other controls

138 Operator comfort

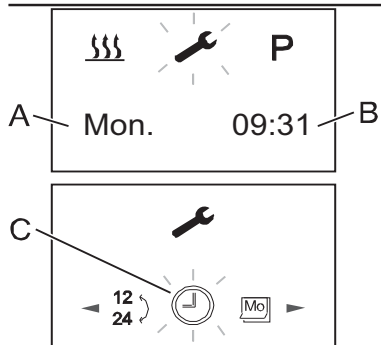

V1154262

- A Current day
- B Current time
- C Settings submenu bar



3 Settings

This function is for setting current day and time.

- 1 Use the backward or forward button to select the setting symbol in the menu bar.
- 2 Confirm the setting menu by pressing the confirm button.
- 3 Use the backward or forward button to select the submenu which want to change the setting.
- 4 Press the confirm button to confirm the setting value.

Error messages

In the event of a fault the following displays are possible:

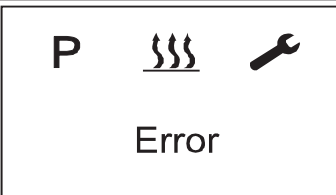
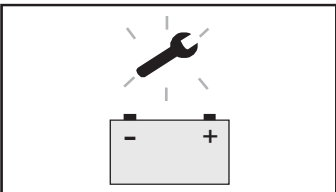
Display	Description	Remedy
 <p style="text-align: right; font-size: small;">V1154443</p>	<ul style="list-style-type: none"> - Automatic detection is active. - The auxiliary heater timer has been disconnected from the power supply and then reconnected. 	<p>Wait until the automatic detection has finished, then set the time and weekday.</p>
 <p style="text-align: right; font-size: small;">V1154444</p>	<ul style="list-style-type: none"> - No communication. 	<p>Check and if necessary renew the heater fuse. Contact a qualified service technician.</p>
 <p style="text-align: right; font-size: small;">V1154445</p>	<ul style="list-style-type: none"> - Heater fault. 	<p>Contact a qualified service technician.</p>
 <p style="text-align: right; font-size: small;">V1154447</p>	<ul style="list-style-type: none"> - Voltage too low. 	<p>Charge battery, if necessary contact a qualified service technician.</p>

NOTE!

If you are unable to remedy the error or fault, contact a qualified service technician.



Operating instructions

This chapter contains rules which must be followed in order to operate the machine safely. However, these rules are to be followed in conjunction with laws or other national regulations applicable to road safety and labour welfare.

Alertness, judgement and respect for applicable safety regulations are conditions for avoiding risk of accidents.

Running-in instructions

During the first 100 hours, the machine should be operated with a certain care. It is important to check oil and fluid levels often during the running-in period.

Visibility



Risk of serious accidents.

Machine parts, equipment or load could obstruct the operator's view. Operating or driving with obstructed operator's view could cause serious accidents.

Use a signal man if operator's view is obstructed.

It may not be possible to provide direct visibility to all areas around the machine. To achieve acceptable visibility, additional devices, such as warning systems, mirrors and closed-circuit television cameras (CCTV) may be used.

For more information about the rear and side view camera system see page 130.

NOTE!

Some parts of the basic machine may restrict visibility, for example the cab's pillars, frames, exhaust pipe, engine hood, as well as optional equipment such as buckets, pallet forks, grapples, and so on. The load that is handled with these attachments may also restrict visibility.

In order to minimize hazards that may be caused by restricted visibility, rules or procedures shall be established by the job site management.

For example:

- Ensure that operators and job site workers have received thorough safety instructions.
- Control the traffic patterns for the machine and other vehicles. Avoid travelling in reverse if possible.
- Restrict the machine's operation area.
- Use a signalman to help the operator. Use signals according to the signal diagram, see 243.
- Provide two-way communication equipment if necessary.
- Ensure that job site workers communicate with the operator before approaching the machine.
- Use warning signs.



Visibility requirements

The Machines meet the standard ISO 5006 "Earthmoving machinery – Operator's field of view". The tests were conducted on stationary machines with equipment and attachments provided by Volvo.

The method used to evaluate visibility cannot include all aspects of the operator's visibility, but gives information to determine if optional equipment for indirect visibility is necessary, e.g., warning systems.

The operator must be informed if other equipment and attachments are used and visibility has been reduced.

NOTE!

If the machine configuration has been changed a new risk assessment and test regarding ISO5006 must be performed.

Mirror and camera settings

Mirrors, adjusting

ISO 5006 states that an imaginary boundary line around the machine must be visible to the operator.

Adjust mirrors until the imaginary boundary line is visible to the operator, see table and figures below.

Stand the unloaded machine straight and on level ground.

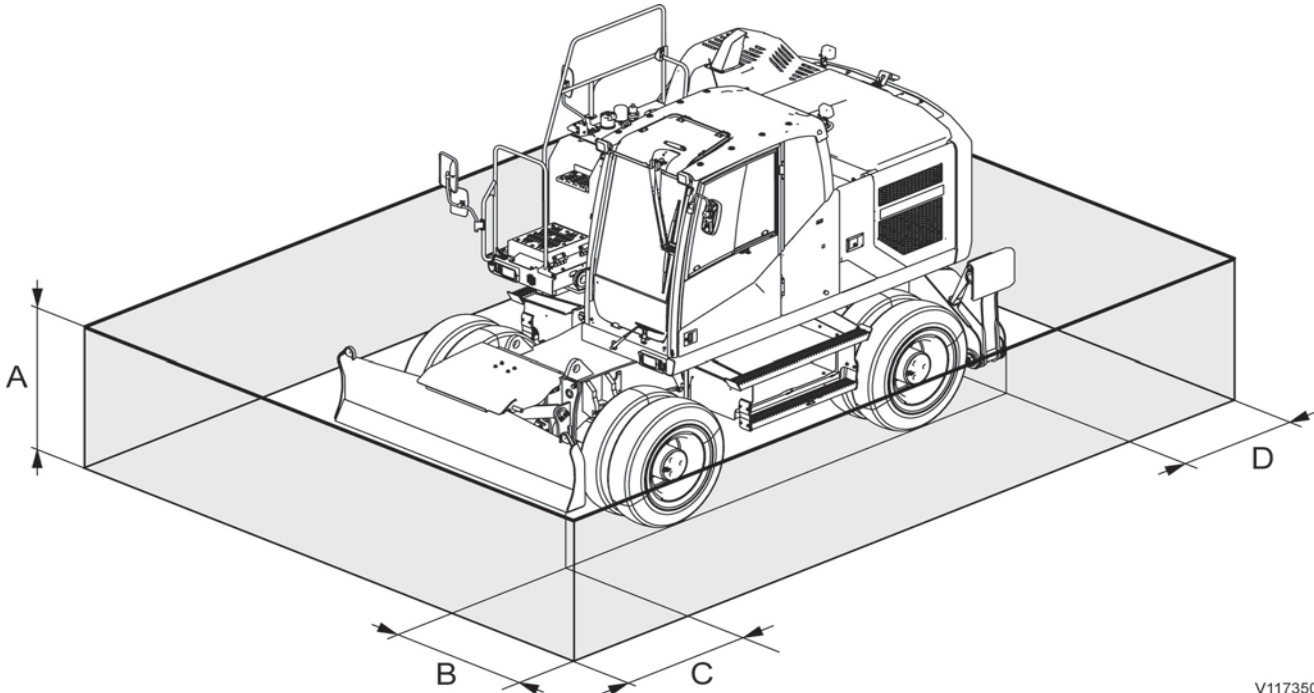

V1173501

Close-up visibility boundary according to ISO 5006 (thick line)

A	1.2 m (47.2 in)
B	1.0 m (39.4 in)
C	1.0 m (39.4 in)
D	1.0 m (39.4 in)

Rear-view mirrors

Using the rear-view mirrors, check that you have as good visibility as possible towards the machine's superstructure and lower frame, and with as wide angle as possible.

If not, adjust the rear-view mirrors until good visibility is obtained, see figures.

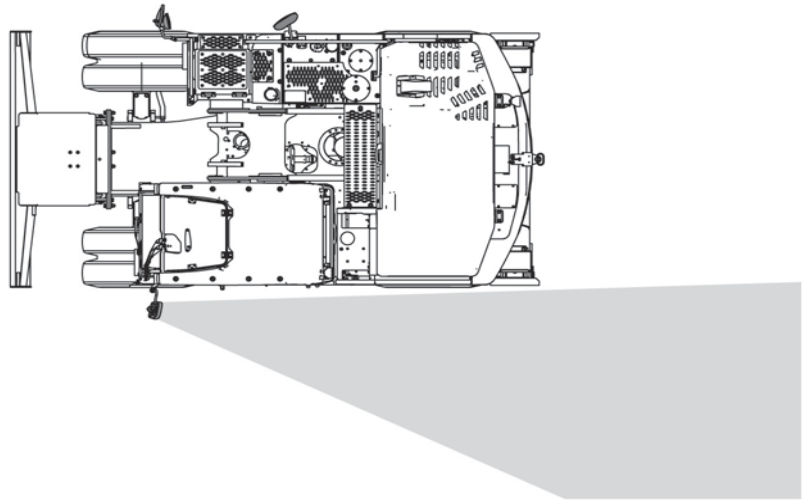
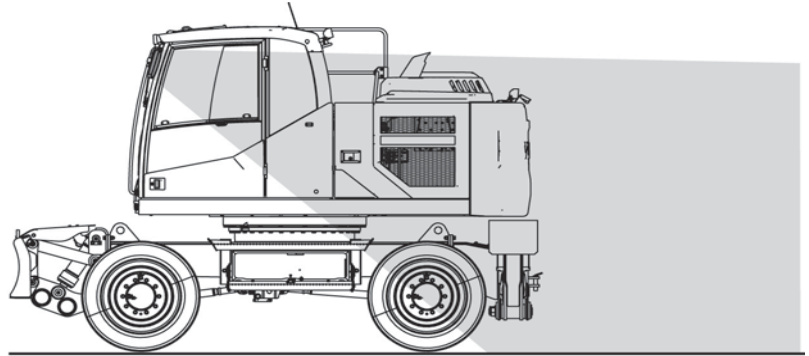
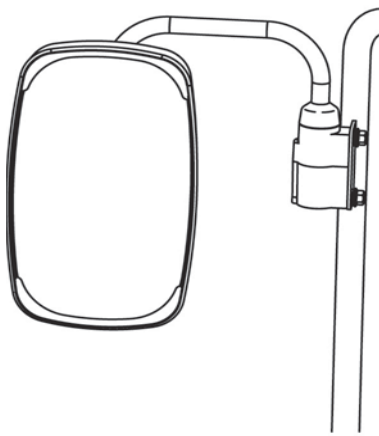

Left mirror

Operating instructions

144

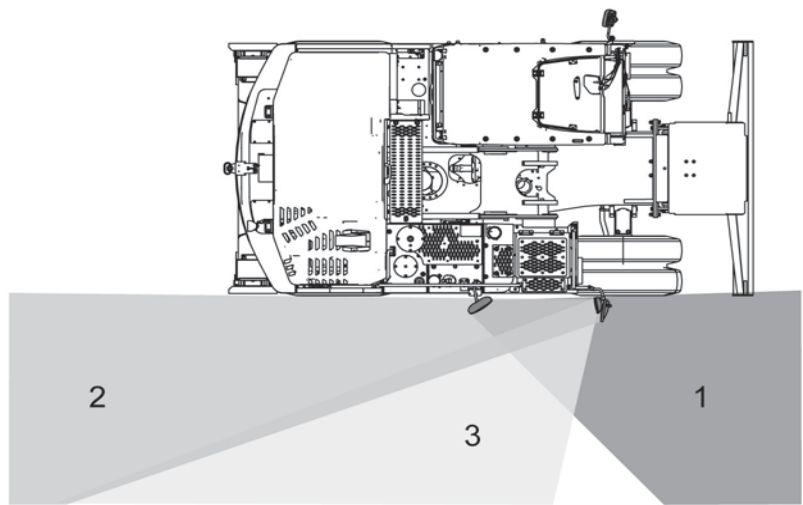
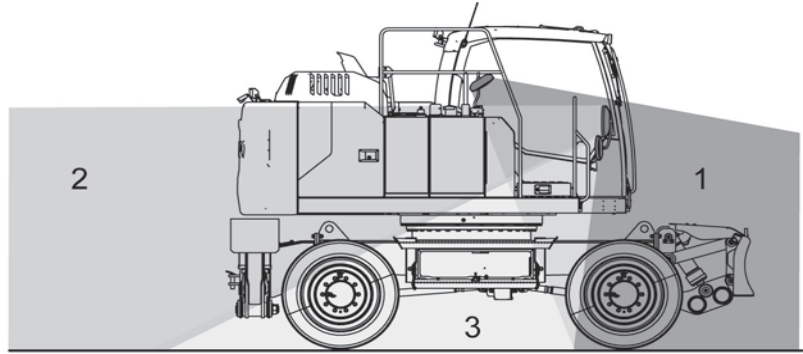
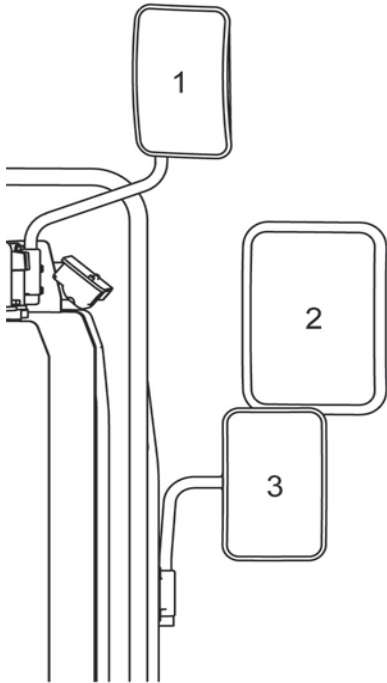

V1173503

Right mirrors



Measures before and during operation

- Walk around the machine and check that there are no obstacles next to the machine.
- Check that mirrors and other visibility-enhancing devices are in good condition, clean, and correctly adjusted.
Clean the cameras (if installed) to always have a clear picture on the screen.

NOTE!

Always use an appropriate ladder or an appropriate platform to get access to the cameras for cleaning purposes.

- Check that the horn, back-up/travel alarm and rotating warning beacon (optional equipment) are working properly.
- Always follow the rules and procedures established by the job site organisation.
- Always pay attention around the machine to identify any obstacles.
- Prevent persons from entering or remaining in the work area, i.e. the area around the machine and at least 7 m (23 ft) beyond the maximum reach of the attachment.
Some applications (e.g. Lifting operation) requires a person in the vicinity of the machine. Depending on the job site organisation the operator may allow a person to remain in the work area, but must then observe caution and operate the machine only when the person is visible or has given clear indications of where he or she is.
Never allow any person to walk or stand under raised equipment or suspended loads.

Safety rules when operating

Follow the safety rules in the Operator's Manual before performing any operation.

Operator obligations

WARNING

Risk of fatal accidents.

Unauthorised persons within the work area around the machine could lead to serious crushing injury.

- Clear all unauthorised personnel from the working area.
 - Keep a lookout in all directions.
 - Do not touch control levers or switches during start.
 - Sound the horn before beginning operation.
- Operate the machine in such a way that the risk of accidents is minimized for both operator and persons present at the work site.
 - You must be thoroughly familiar with how to operate and maintain the machine and should complete adequate training on the machine.
 - You must follow the Operator's Manual rules and recommendations, but also pay attention to any statutory and national regulations or specific requirements or risks which apply at the work site.
 - You must be well-rested and must never operate the machine when under the influence of alcohol, medicine or other drugs.
 - You are responsible for any load carried by the machine while working with the machine.
 - There must be no risk of the load falling off while operating.
 - Refuse to take a load which is an obvious safety risk.
 - Respect the stated maximum load for the machine. Pay attention to the effect of different distances to the centre of gravity and the influence of different attachments.
 - You must check that all mirrors and cameras are in good condition, clean, and properly adjusted for good visibility before operating the machine. For detailed information about adjustment of mirrors and cameras see page 140.
 - You must be in control of the working area of the machine.
 - Prevent persons from walking or standing under raised excavating equipment or suspended loads, unless it has been made safe or supported.
 - Prevent persons from entering or remaining in the work area, i.e. the area around the machine and at least 7 m (23 ft) beyond the maximum reach of the attachment.

Some applications (e.g. Lifting operation) requires a person in the vicinity of the machine. Depending on the job site organisation the operator may allow a person to remain in the work area, but must then observe caution and operate the machine only when the person is visible or has given clear indications of where he or she is.
 - Prevent persons from being in the cab of a vehicle which is placed so that there is a risk that the cab may be hit by other machines or falling objects, for example stones or logs. This does not apply if the cab is sufficiently strong or protected to withstand the impact of such external forces.
 - You may only take an instructor on board, if there is an approved instructor's seat in the machine.
 - Make sure you know the weight limitation of working ground.

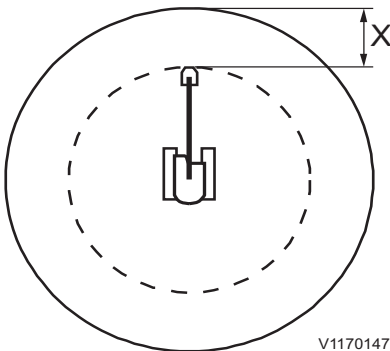

V1170147

WARNING

Risk of fatal accidents.
Using attachments for lifting or transporting persons may lead to fatal accidents with serious crushing injury or death.
Never use attachments for lifting or transporting persons.

Operator obligations — risk of fire

WARNING

Risk of fire.
Operating in environments with flammable or other explosive particulates in the air could increase the risk of fire.
Use special equipment and proper ventilation when operating in hazardous environments.

CAUTION

Risk of fire!
Waste between the machine components could be caused a fire.
To avoid fire hazards, remove all wastes daily.

Operator obligations — risk of high pressure injection

WARNING

Risk of high pressure injection.
Oil or fuel leaks from high pressure hoses could cause serious injury caused by high pressure injection.
If oil or fuel leaks from high pressure hoses or loose screws are found, stop operations immediately and contact a qualified service technician.

Accidents

- Accidents and also incidents should be reported to the site management immediately.
- If possible leave the machine in position.
- Only take necessary action so as to reduce the effect of damage, especially personal injuries. Avoid action which may make an investigation more difficult.
- Wait for further instructions from the site management.

Operator safety

- The machine must be in such condition that functional disorder do not occur which may cause accidents.
- Wear suitable clothing for safe handling and a hard hat.
- Always sit in the operator seat when starting the engine/ machine.
- Keep your hands away from areas where there is a risk of crushing, e.g. covers, door and windows.
- Always use the seat belt. Check that the seat belt is not worn, see page 117.
- Use steps and handholds when entering or leaving the machine. Use the three-point grip, i.e. two hands and one foot or two feet and one hand. Always face the machine – do not jump!
- Only step on surfaces which are provided with anti-slip protection.
- The door must be closed when operating the machine.

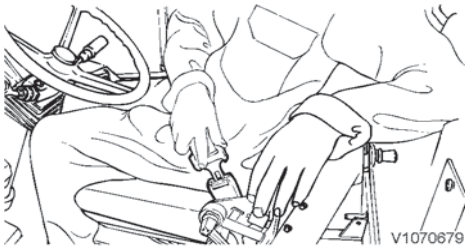

- Check that the attachment is properly attached and locked.
- The vibration (shaking) which arises when operating may be harmful to the operator. Reduce this by:
 - adjusting the seat and tightening the seat belt.
 - picking the smoothest operating surface for the machine (levelling the surface when necessary).
 - adapting your speed.
- The cab is for the protection of the machine operator and it meets the requirements for Roll Over Protective Structures according to the testing standard "ROPS" or "TOPS" (depending on machine configuration). Therefore, hold firmly onto the steering wheel if the machine should roll over - do not jump.
- The cab is also designed to meet the requirements for falling objects (optional equipment), the weight of which agrees with testing methods according to "FOPS".
- The cab has one emergency exit, the rear window.
- During electrical storms, do not enter or exit the machine.
 - If you are off the machine, stay well away from the machine until the storm passes.
 - If you are in the cab, remain seated with the machine stationary until the storm passes. Do not touch controls or anything metal.
- Take part in the emergency plan for the working site or other instructions about measurements in case of accidents.
- During a parked DPF regeneration the exhaust temperature is rising above the normal temperature level, therefore, during a parked regeneration following rules apply:
 - Make sure that there is no flammable material around the machine, this is important to prevent risk of fire.
 - Move the machine to a safe area, if there is a risk that people may get too close and then perform the regeneration.

! WARNING

Risk for fire.

Regeneration generates hot exhaust and causes hot exhaust pipe. Do not perform regeneration in a flammable environment.

Operating on public roads

- Road signs, traffic restricting arrangements and other safety devices, which may be required when considering traffic speed and intensity or other local conditions, must be used.
- When moving the machine with a suspended load, special attention must be observed. When required, request the help of a signal man.
- Use lights, hazard flashers and rotating warning beacon according to national traffic regulations.

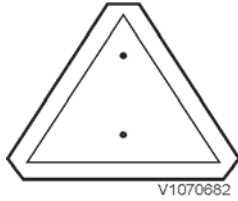

SMV plate

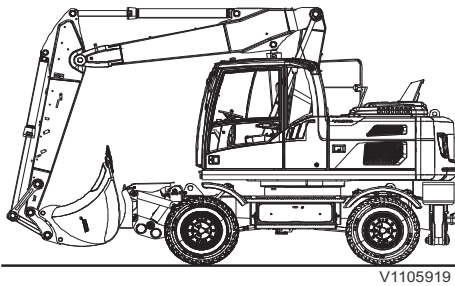

Position of attachment when travelling on public roads

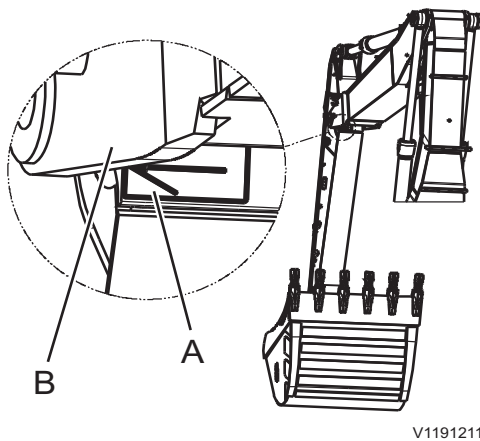

A: Traveling position decal (EW160E, optional)

Travelling on public roads

As a machine operator you are considered to be a road-user and therefore you are obliged to know and follow local regulations and national traffic regulations.

It is important to bear in mind that the machine, in comparison with the rest of the traffic, is a slow moving and wide vehicle, which may cause obstruction. Bear this in mind and pay attention to the traffic behind you. Facilitate overtaking.

The use of a SMV-plate (Slow Moving Vehicle plate) is regulated in law in some countries. Check your national traffic regulations.

Before the machine may be driven (operated) on public roads, it must be prepared as follows:

- Clean the machine from mud and stones to avoid pollution on the road and damage on other vehicles.
- Put the mode selector in T-mode.
- Align the superstructure with the undercarriage. When the superstructure is aligned, the control lamp lights with a fixed light.
- Put the mode selector in W- or C-mode.
- Raise the stabiliser blade, if installed, until the cover on top is horizontal.
- Raise the stabiliser legs fully.
- Empty the bucket and lay it in travelling position.
For EW160E (optional): Watch the decal (A) and move the arm out until the arrowhead is aligned with the underside of the second boom (B).
- If a trailer is attached to the machine during operation on public roads it must not be lifted.
- Put the mode selector back to T-mode and check that the superstructure is still aligned and all hydraulics are locked.
- Close the windscreen(s).
- Switch off the working lights.
- Wear seat belt at all times during machine operation.

NOTE!

Travelling on public roads is only allowed in T-mode (travel mode).

- Always operate the machine in its natural direction of travel, i.e. the steered wheels at the front.
- Use lights, hazard flashers and rotating warning beacon according to national traffic regulations.
- Keep an eye on persons in the proximity of the machine. Ask someone to indicate to you how to move the machine if you are not sure how to do this without risk.
- Never exceed the maximum permitted load for bridges.
- Keep a tab on the permitted axle loads. Bear in mind that the axle loads of the machine may change depending on the attachment.
- Follow the traffic regulations that apply to the machine.

Operating instructions
150 Safety rules when operating

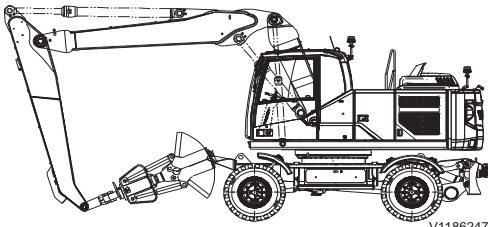

V1186247

Travelling with grab bucket

- Bear the height and length of the attachment in mind.

NOTE!

If the machine is equipped with mesh covers, these have to be removed before travelling on public roads.

Travelling with grab bucket (clamshell bucket)

Machine equipped with a grab bucket (also called clamshell bucket) may only be used for travelling when the bucket is secured to the grab bucket retainer. Grab hold of the retainer with the grab bucket.

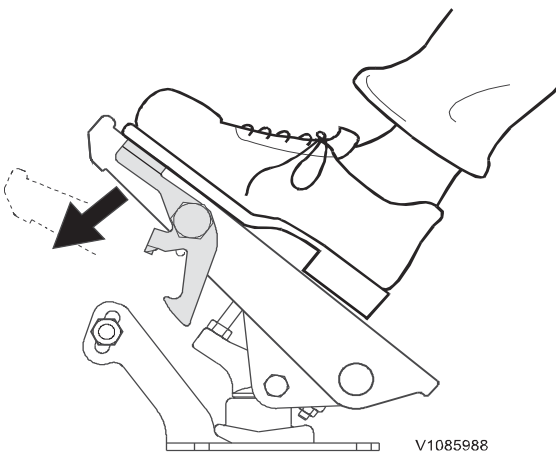

V1085988

Applying the service brake

Travelling on uneven ground

In case of travelling on uneven ground, retract the attachment and raise it 40–50 cm from the ground.

Check national regulations regarding driving on public roads.

NOTE!

When applying the service brake, both the service brake pedal and the digging brake release lever must be depressed together, otherwise the digging brake may be engaged, locking all the wheels.

Align the superstructure with the undercarriage

NOTE!

In T-mode all hydraulic functions are locked if the machine is aligned. If attachment must be moved the mode needs to be changed to W- or C-mode. Make sure to switch back to T-mode before travelling on public roads.

- 1 Put the mode selector in T-mode.
- 2 Swing the superstructure into line with the undercarriage.
When the superstructure is aligned, the control lamp lights with a fixed light.



V1085994

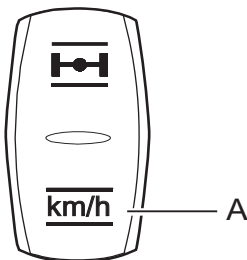

V1152237

A - Axle lock and cruise control switch

Cruise control (optional equipment)

Engage the cruise control by pressing the travel pedal until the desired speed is reached and then press down the lower part of the switch (B) until the cruise control symbol appears in the IC (Instrument Cluster).

For detailed information about speed control and disengagement of the cruise control see chapter instrument panel right starting on page 80.

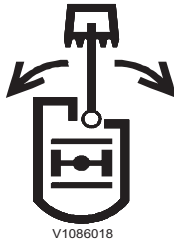

V1086018

Always engage the pivot axle locking when swinging the superstructure.

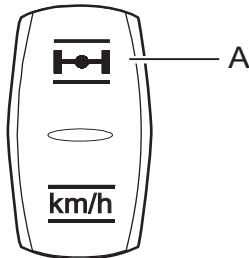

V1151955

A — Axle lock and cruise control switch



V1186331

B — Pivot axle automatically locked (yellow)



V1187370

C — Pivot axle unlocked



V1085794

D — Pivot axle manually locked (green)

Pivot axle locking

⚠ WARNING

Risk of serious accidents.
Swaying load could cause accidents with serious injury.
Always lock the pivot axle before travelling with a suspended load.

NOTICE

Connect the pivot axle lock when the machine is transported on a trailer, when travelling with a load or when operating in situations where the stabiliser legs or stabiliser blade cannot be used.

The front axle is pivoted relative to the undercarriage frame to provide the best possible ground contact when travelling over uneven ground. The maximum pivoting angle is 9 degrees in either direction.

With a locked pivot axle, the traction while driving on uneven ground is limited.

Automatic pivot axle locking

The axle is automatically locked if:

- the engine is not running
- or, the ignition key is off
- or, if P-mode is selected
- or, the control lockout lever is in lower position
- or, the brake pedal is pressed down (brake pressure higher than 60 bar).

In this case the yellow control lamp (B) is shown in the IC (Instrument Cluster).

The automatic axle locking is disengaged if none of the above mentioned conditions is fulfilled and the axle is not manually locked.

If the pivot axle is unlocked the pivot axle unlocked symbol (C) is shown in the IC (Instrument Cluster).

Manual pivot axle locking

The axle can be manually locked by pressing the upper part of the switch (A) on the right instrument panel (see page 80) or with the button on the left control lever (see page 91).

NOTE!

If the machine is in T-Mode a manual locking of the pivot axle is not possible.

It is possible to engage the manual pivot axle locking while it is engaged automatically, so that the axle stays locked when the conditions for automatic locking is not fulfilled any more. In this case the green control lamp (D) is shown in the display unit.

The pivot axle locking can be disengaged manually by pressing the upper part of the switch (A) or the button on the control lever for more than 1 second, if the automatic axle lock is not active.



Operating instructions
152 Measures before operating

Measures before operating

NOTE!

The safety regulations and operating instructions issued by the manufacturer of the machine and attachments must strictly be observed.

- 1 Read the Operator's manual.
- 2 Carry out daily service, see page 268.
In cold weather, make sure that the freezing point of the coolant is sufficiently low and that the lubricating oil and fuel is intended for winter use.
- 3 Make sure the fire extinguisher (if equipped) is fully charged.
- 4 Check that hoods and covers are closed.
- 5 Check that the battery disconnect switch is switched on.
- 6 Check the IC (Instrument Cluster) for failure messages.
- 7 Adjust the steering wheel and the operator seat, see pages 91 and 112.
- 8 Fasten the seat belt.
- 9 Check that there are no persons in the work area of the machine.
- 10 Check that the attachment is securely locked before use.

Starting engine

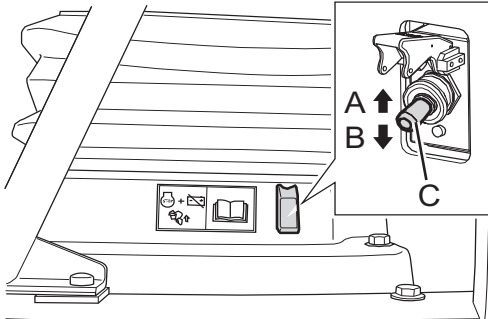

V1149247

Battery disconnect switch

- A OFF position
- B ON position
- C Battery disconnect switch

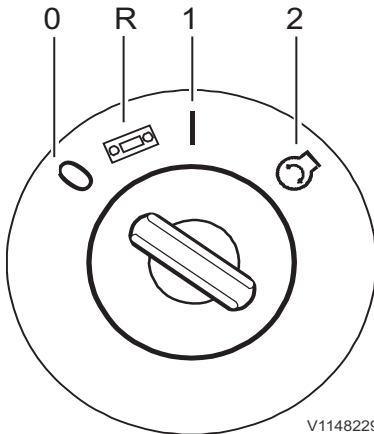

V1148229

Ignition switch

- OFF position (0)
- Radio position (R)
- Operating (preheating) position (1)
- Start position (2)

CAUTION

Risk of accidents.

Uncontrolled machine movement could lead to accidents.

Sit in the operator seat with a good view of the work site and the machine, before starting the engine.

- 1 The battery switch is located inside the cabin.
- 2 Connect the battery by opening the red cover of the battery disconnect switch (C) and pressing the switch to the lower position (B).
- 3 Sound the horn before starting the engine.
Keep an eye on people in the vicinity of the machine.
Ask someone to help by giving signals, if the machine cannot be moved without risks.
- 4 Turn the ignition switch to start position (2) and keep it there until the engine starts. Do not race the engine immediately after start.
- 5 The camera view is shown in the IC (Instrument Cluster) at every machine start, it could be closed with the ESC button.
- 6 If the machine is equipped with anti-theft protection, see page 70.
Cold starting, see page 154.

NOTE!

Do not keep the ignition switch in start position (2) for more than 20 seconds, as this may seriously damage the starting system. If the engine does not start, turn the switch back to OFF position (0) and wait a couple of minutes before the next starting attempt.

NOTICE

Wait until the electronic system is completely shut down before restarting.

- 7 Check the travel lights and working lights. If a travel alarm is installed, check this function.
- 8 Warm up the machine, see page 157.

154 Operating instructions
Starting engine

Starting engine in cold weather

! WARNING

Risk of explosion.
Spraying flammable starting aids into engine components could cause an explosion.
Never use starting aids while attempting to start the engine.

NOTICE

Never race the engine immediately after a cold start. The lubrication of the engine will be jeopardised resulting in a shortened service life and great risk of damage to bearings.

The engine has an automatic preheating element, which is an aid when starting a cold engine. The machine may also be equipped with an engine block heater, see page 154.

NOTICE

Do not abort the starting attempt too early if the engine is cold. If the engine does not start at the first attempt, wait a short while before the next attempt to give the batteries and the starter motor time to recover.

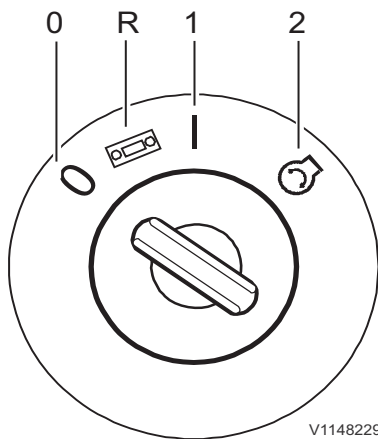

V1148229

Ignition switch

- OFF position (0)
- Radio position (R)
- Operating (preheating) position (1)
- Start position (2)



V1065463

Engine preheating symbol

- 1 Turn the ignition switch to operating (preheating) position (1) and keep it there as long as the engine preheating symbol is displayed in the IC (Instrument Cluster).
- 2 As soon as the preheating symbol has extinguished, turn the ignition switch to start position (2) and keep it there until the engine starts.

NOTICE

Never race the engine immediately after a cold start.

- 3 If the engine should stop: wait for a while before you make the next starting attempt.
- 4 Warm up the machine, see page 157.

Engine block heater

(optional equipment)

This equipment is used to reduce the engine load which cause the wear in the engine when starting the machine in cold weather region.

If an engine block heater is installed in your machine you also have a cable to connect it to the external power supply.

NOTE!

The machine may be equipped with cylinder block heater for either 120 V or 240 V. Before connecting, compare the specified voltage of the external power supply and with that of the engine block heater.

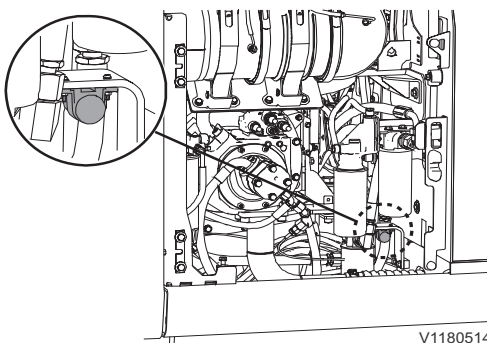

V1180514

Socket for block heater

Starting with booster batteries

When starting with booster batteries, the following must be observed:

Check that the booster batteries or other power source have **the same voltage** as the standard batteries.

WARNING

Risk of explosion.

Batteries could explode due to the current surge if a fully charged battery is connected to a completely discharged or frozen battery.

Do not boost start a machine with a completely discharged or frozen battery.

WARNING

Risk of explosion.

Boost-start can cause flammable gas emission from the battery. Sparks near the battery can cause an explosion resulting in serious injury.

Avoid short-circuits, open flame or electrical spark. The machine being boost-started must not come in contact with the supplying machine.

Follow these steps:

- 1 Turn OFF the battery disconnect switch.
- 2 Remove the protections from the battery pole studs.
- 3 Check that the booster batteries or other power source have the same voltage as the standard batteries.
- 4 Do not disconnect the cables to the standard batteries!
- 5 Connect (+) on the booster battery to (+) on the battery nearest the starter motor.
- 6 Connect the other start cable from (-) on the booster battery to the machine chassis, such as on the frame member close to the starter motor.
- 7 Start the engine with the ignition key in the cab.
- 8 Once the engine has started, remove the start cable between the chassis and the booster battery negative terminal (-). Then remove the start cable between the positive terminals (+).
- 9 Refit the terminal caps on the battery terminals.



Turbocharger

NOTICE

Racing the engine immediately after it has been started may damage the turbocharger.

Run the engine at low idling speed for at least half a minute after start and before it is turned off. This is to ensure the lubrication of the turbocharger.

Hydraulic system, warming up

⚠ WARNING

Risk of crushing injury.

The hydraulic system could respond slowly at low temperatures and could cause unexpected machine movements.

Operate carefully until the hydraulic system has reached operating temperature.

When the oil is cold it is viscous, therefore the hydraulic functions of the machine operate slower than when the oil is warm.

If one or more of the machine functions are forced against the end-of-stroke position without having first warmed up the system, this may result in unexpected movements and machine damage.

NOTE!

During the warming up the operating control lockout lever must be in its unlocked position.

NOTICE

Do not rush warming of the oil, since forced warming can damage the machine.

- 1 Start the engine and leave it running at low idling for five minutes (ten minutes at below $-15\text{ }^{\circ}\text{C}$ (5°F))
- 2 Turn the mode selector switch to working mode (W).
- 3 Increase the speed to approx. 1200 rpm.
- 4 Run the bucket cylinders piston rod to the outer end position and at the same time, run the dipper arm out and in.
- 5 Check on the display unit if the bar graph for the oil temperature is green (see 50).

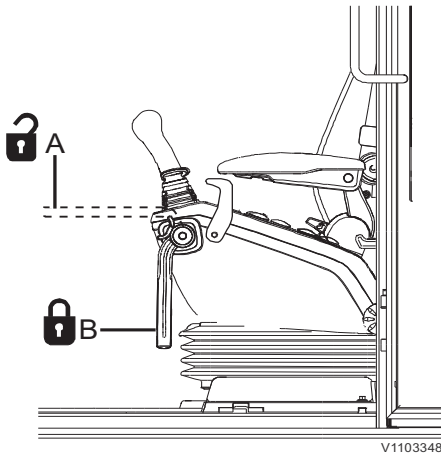

A — Control lockout lever in unlocked position

Travelling a short distance

Moving the machine a short distance (e.g. when loading onto or off a trailer) may be done without a complete warm-up. This operation must be done with great care. Under these conditions the engine speed must not exceed 1200 rpm and the travel speed control switch should be in creep position.

Operating

Always start the engine with the parking brake applied.

The travel direction, forward or rearward, is selected on the right control lever, see page 94.

NOTE!

Countering is allowed, i.e. the machine does not have to be stationary when selecting a change of travelling direction.

Steering

If the machine is equipped with steering wheel and Comfort Drive Control (CDC) function the steering is done with the steering wheel until CDC function is activated with the CDC switch on the right instrument panel.

If the machine does not have a steering wheel the Comfort Drive Control (CDC) function is always activated.

For more information about the CDC function see page 161.

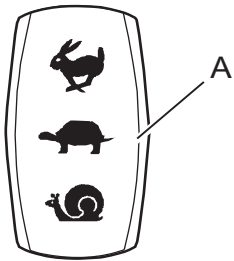

V1184646

A — Travel speed switch

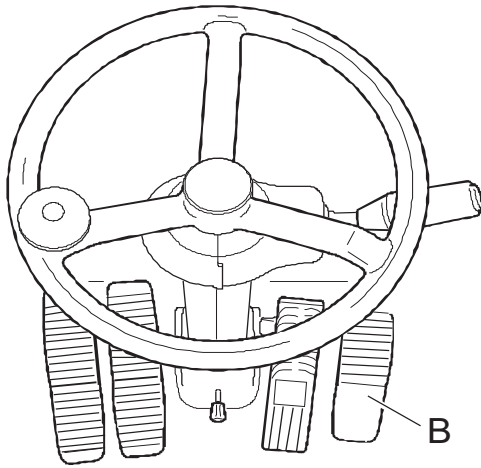

V1184641

B — Travel pedal

Speed

The travel speed (high / low / creep) is selected with the travel speed switch (A) on the right instrument panel and controlled with the travel pedal (B).

For details about the travel speed switch see page 158.

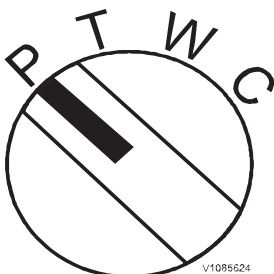

V1085624

Mode selection

Select mode with the mode selector on the right instrument panel.

P = parking mode (parking brake and pivot axle locking are applied)

T = travel mode (public roads)

W = work mode (operating)

C = customer mode (own flow settings)

NOTE!

Power boost is active in T-, W- and C-mode if travel pedal is pressed.

Travelling speed

Select the travelling speed with the button on the right instrument panel, you can choose between high, low and creep travelling speed.

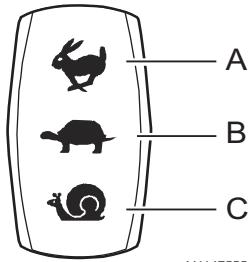

V1147555

Travelling speed button

- A high
- B low
- C creep

NOTICE

When driving down a slope with an inclination of more than 12 %, select the same gear as you would if you were driving up the same slope.

To moderate the speed, particular when travelling downhill, it is always recommended using the service brake and shifting to the next lower gear. If the travel pedal is let up only the hydrostatic brake becomes active, but this brake function is not sufficient to reduce the speed and has also an impact on wear resistance of the driveline because of overheating.

NOTE!

Overheating the hydraulic motor and brake system could cause serious failures, avoid overheating of the machine by operating it carefully.

Steering

Steering

Steering of the machine can be done with the steering wheel or the optional Comfort Drive Control (CDC) function.

The travel speed is selected with the travelling speed button on the right instrument panel, see page 158.

The driving direction is always selected on the right control lever.

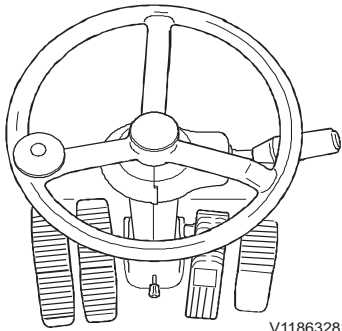

Steering wheel

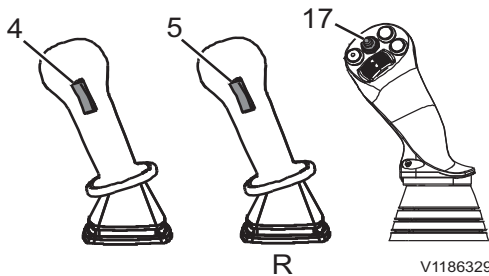

R - Right control lever

Driving direction (Forward/Neutral/Rearward)

The driving direction F/N/R is selected with a dedicated switch on the right control lever.

F/N/R switch:

Button control levers: switch 4

Proportional control levers: switch 5

L8-5 control levers: switch 17

F/N/R switch positions:

Position 1 — Forward

Position 2 — Neutral

Position 3 — Reverse

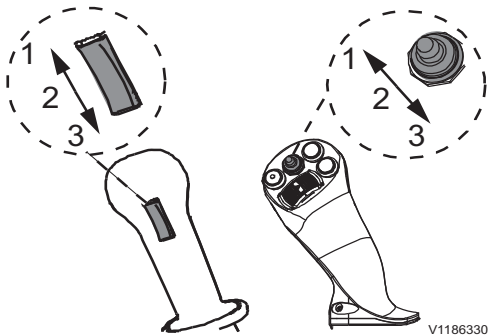

F/N/R switch

Comfort Drive Control (CDC)

(optional equipment)

With the optional Comfort Drive Control (CDC) function the machine can be steered by using a proportional switch on the left control lever.

Forward and reverse is selected with the direction switch on the right control lever.

The CDC option is only available in combination with the L8-5 control levers.

CDC control lever steering

Steering: The steering to the left or to the right is done with the proportional switch (6) on the left control lever.

Proportional switch (6):

moved to left — steer to the left

moved to right — steer to the right

NOTE!

The proportional switch goes back to starting position without moving the wheels as soon as it is released.

Forward/Neutral/Reverse: The driving direction F/N/R is selected with switch (17) on the right control lever.

F/N/R switch (17):

switched forward — Forward

in middle position — Neutral

switched backward — Reverse

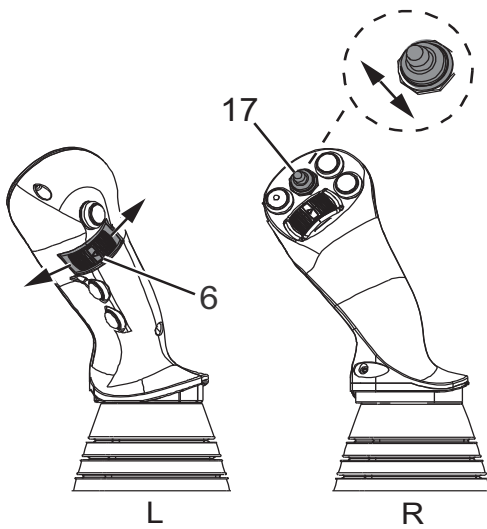

V1184620

L — Left control lever
R — Right control lever

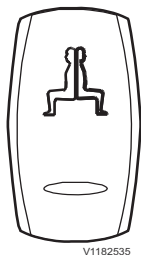

V1182535

CDC activation switch

CDC activation (with steering column)

The CDC function can be activated by pressing the CDC activation switch on the right instrument panel for 2 seconds.

Following conditions must be fulfilled for CDC activation:

- Engine running.
- Mode selector in W- or C-Mode (activation in T-Mode not possible).
- Control lockout lever in upper position.
- Driving speed below 5 km/h (3 miles/h).

NOTE!

It is not allowed to drive on public roads with the CDC function activated!

The CDC function shall only be used in W- or C-mode.

While CDC is active, the maximum speed is limited to 20 km/h (12 miles/h).

If the control lockout lever is lowered while CDC is active, CDC will still be active if the control lockout lever is raised again.

NOTE!

The steering wheel has always priority over steering by the proportional switch.

CDC active at machine start

If CDC is active at shutdown of the machine, CDC will automatically be activated at next machine start when the engine is running and the control lockout lever is in upper position.

CDC display messages (with steering column)

If the CDC activation switch is pressed for 2 seconds the CDC symbol comes up in the IC (Instrument Cluster). After releasing the switch a pop up message comes up with the text "CDC enabled".

While CDC is active the CDC symbol is alight in the lower part of the IC (Instrument Cluster).

If the mode is changed to T-Mode a caution message pops up in the IC (Instrument Cluster) with the text "CDC still active" and the buzzer sounds as long as T-Mode and CDC are active.



V1186165

CDC symbol

CDC activation / display messages (without steering column)

If the machine does not have a steering column it can only be steered with the control levers with Comfort Drive Control (CDC) option.

NOTE!

It is not allowed to drive on public roads with machines without steering column!

The CDC function is always active except if machine is in P-Mode, engine is not running or control lockout lever is down.

The CDC symbol in the IC (Instrument Cluster) is always alight.

CDC steering speed

The CDC steering speed can be adjusted in the Setup menu, see page 58.

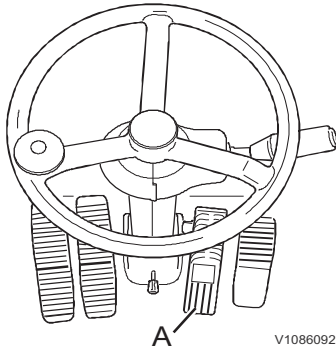

Braking

Service brake

The service brake acts on all wheels and is operated with the service brake pedal (A).

Depress the brake pedal and toggle lever at the same time to apply the service brake.

NOTE!

The digging brake is engaged if the toggle lever on the brake pedal is locked, see page 164.

Parking brake

The parking brake is a negative action disc brake integrated in the travel gearbox. The brake is applied by spring force and hydraulically released.

The parking brake should only be used when the machine is stationary.

- Apply the parking brake by setting the mode selector in P-mode or setting the control lockout lever in the downward position.
- Release the parking brake by setting the mode selector in T-, W- or C-mode and setting the control lockout lever in the horizontal position.

NOTICE

Never apply the parking brake when the machine is moving. Only in an emergency may the parking brake be applied to slow down the travelling speed of the machine.

Operating instructions
164 Braking

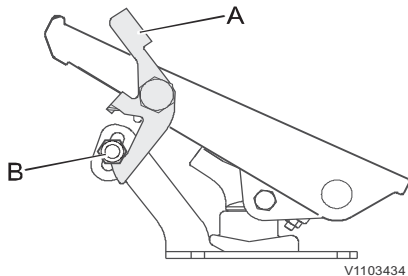

Brake pedal

Toggle lever for brake lock (digging brake)

The digging brake is made up of the service brake and a locking mechanism on the service brake pedal consisting of a toggle lever (A) and a lock pin (B).

- Apply the digging brake by depressing the service brake pedal, without depressing the toggle lever, so that the toggle lever engages the lock pin.
- Release the digging brake by pressing down the toggle lever.

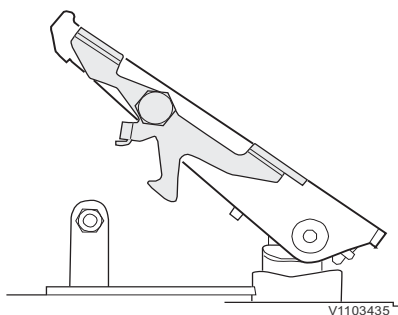

Toggle lever locked in parallel position to the service brake (only possible when equipped with electrical digging break)

Electric digging brake (optional equipment)

If the machine is equipped with electric digging brake, the service brake pedal will lock electro-hydraulically in W- or C-mode when the machine is standing still.

The toggle lever must be locked in a parallel position to the service brake for the electric digging brake to function, otherwise the digging brake will work mechanically, see above.

To lock the toggle lever in a parallel position to the service brake press down the upper end of the toggle lever without depressing the service brake and to release press down the lower end.

Use the switch on the right instrument panel to select and apply the electric digging brake.

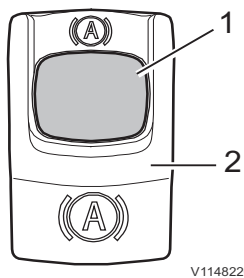

Switch for electric digging break

- Upper end of switch pressed down = electric digging brake is selected or deactivated.
- Releasing the red locking device (1) by pressing it down and pressing down the upper end of the electrical digging brake switch (2) simultaneously = electric digging brake is applied, provided that W- or C-mode is selected, the toggle lever is locked parallel to the service brake and the machine is standing still.

The electric digging brake is released when the engine is running, T-, W- or C-mode is selected, the control lockout lever is in upper position, travel direction is selected and the travel pedal is pressed.

In this case the pivot axle locking is unlocked too.

In case of manually locked pivot axle locking the axles stay locked.

NOTICE

If the brake pressure is too low or if a fault occurs on the electric digging brake, press the upper end of the switch and turn off the engine. Start the engine again and apply the digging brake with the pedal instead.

Exhaust aftertreatment system

Regeneration

WARNING

Risk of burns.

Engine and exhaust system components get very hot and can cause severe burns.

Avoid contact with engine compartment covers, engine components and exhaust system until the engine is cooled down.

NOTE!

Some smoke might be seen coming from the exhaust stack during regeneration of the aftertreatment system on a machine run on diesel fuel with high sulfur content.

The purpose of regeneration is to raise the temperature in the aftertreatment system so that any trapped substances are burned off to allow the system to regain its full capacity.

Normal operation

During normal operation, passive regeneration occurs continuously.

No further action is required from the operator during the passive regeneration.

Only if the machine cannot run a passive regeneration, due to any certain circumstances which are explained on the next pages, a parked regeneration is requested.

166 Operating instructions Exhaust aftertreatment system

Parked regeneration

Parked regenerations have to be run during 500 hours machine service. Or if the soot load in the DPF exceeded the limits for unexpected reasons, e.g. extreme low temperature working or engine combustion problems.

During 500 hours service it is important that the parked regeneration is run before changing the engine oil and replacing the engine oil filter.

It is possible to run a parked regeneration 450 hours after the last parked regeneration was performed using the regeneration menu in the IC (Instrument Cluster).

NOTE!

600 hours after the last performed parked regeneration, the engine power will be derated. After 625 hours, a parked regeneration can only be performed with Volvo's service tool by a qualified service technician!

Alarm messages will first appear in the display 550 hours after the last parked regeneration was run, see table on following pages.

No work can be performed with the machine during a parked regeneration which takes approximately 40 minutes to run. A parked regeneration requires that:

- 1 The engine has reached sufficient working temperature.
- 2 The machine is parked in a fireproof area.
- 3 The control lockout lever is in the lower position to lock the system.
- 4 The engine is running during the entire parked regeneration.

To start a parked regeneration:

Select "Start" in the regeneration menu on the IC (Instrument Cluster).

NOTE!

The regeneration can be started immediately by pressing the SELECT button on the IC (Instrument Cluster) control keypad when an alarm indication for regeneration pops up on the IC (Instrument Cluster).

The HEST (High Exhaust Temperature) light is on, see symbol, to indicate that a parked regeneration is in progress and that the exhaust temperature is high. No further message is displayed. Do not turn off the engine when the HEST-light is on!

NOTE!

The machine must be in an area that is not heatsensitive when the HEST-light is on.

Service regeneration

If a requested regeneration is delayed for too long, the PM (particulate matter)-load in the DPF (diesel particulate filter) will be too high for a safe parked regeneration. Then regeneration must be started with Volvo's service tool in order to perform a safe regeneration.

Fuel consumption

During a parked regeneration, the fuel consumption may increase.

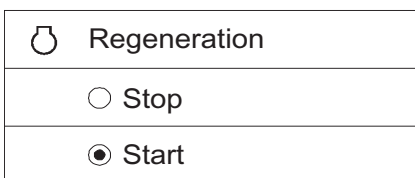

V1147263

Regeneration menu

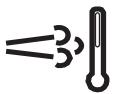

V1083542

HEST-light (High Exhaust Temperature)
(shown when a parked regeneration is in progress)

Delaying regeneration

The regeneration can be delayed by pressing the ESC button on the IC (Instrument Cluster) control keypad when an alarm indication for regeneration pops up on the IC (Instrument Cluster). The alarm indication will pop up again after 15 minutes or when the engine is restarted.

Delayed regeneration may be useful if the machine is in a heat-sensitive environment.

NOTE!

It is important to not delay regeneration unnecessarily.

Possible consequences of delaying regeneration:

- engine derate.
- higher fuel consumption.
- shorter diesel particulate filter service life.
- damage to the aftertreatment system.

Cancelling parked regeneration

NOTE!

Only cancel in an emergency.

- 1 Select "Stop" in the regeneration menu on the IC (Instrument Cluster).

An alarm indication on the instrument panel confirms that regeneration has been cancelled.

Regeneration is cancelled automatically when:













- a malfunction occurs
- machine operation starts and a parked regeneration is in progress
- the machine is turned off



V1135633





Regeneration cancelled

Operating instructions
168 Exhaust aftertreatment system

Alarms that require specific action			
Text on display panel	Display indication	Alarm level	Action
Park soon Parked regeneration needed	Warning, amber   V1128635	- buzzer sounds - amber central warning on	1 Park the machine in a non heat sensitive area. Move the control lockout lever down to lock the system. 2 Start regeneration. NOTE! Regeneration is cancelled if the control lockout lever is set to unlocked position. NOTE! The idle speed increases during the entire regeneration process.
Start regeneration Parked regeneration possible Press [SELECT] to start	Warning, amber   V1128635	- buzzer sounds - amber central warning on	1 Park the machine in a non heat sensitive area. Move the control lockout lever down to lock the system. 2 Start regeneration. NOTE! Regeneration is cancelled if the control lockout lever is set to unlocked position. NOTE! The idle speed increases during the entire regeneration process.
Keep machine parked Regeneration ongoing	Warning, amber   V1128635	- buzzer sounds - amber central warning on	1 Keep the machine parked.
Regeneration cancelled Derate soon	Warning, amber   V1135633	- buzzer sounds - amber central warning on	1 Restart regeneration when possible.
Park machine Parked regeneration required Derate active	Warning, amber   V1128635	- buzzer sounds - amber central warning on - engine derate is activated (but is restored after a completed regeneration)	1 Park the machine. 2 Restart regeneration when possible.
Regeneration cancelled Derate active	Warning, amber   V1135633	- buzzer sounds - amber central warning on - engine derate is activated (but is restored after a completed regeneration)	1 Restart regeneration when possible.



Operating instructions
Exhaust aftertreatment system 169

<p>Park safely Service regeneration needed Derate active</p>	<p>Warning, red</p>  <p>V1128638</p>	<ul style="list-style-type: none"> - buzzer sounds - red central warning on - engine performance is significantly reduced (but is restored after a completed regeneration) 	<ol style="list-style-type: none"> 1 Park the machine in a non heat sensitive area. Move the control lockout lever down to lock the system. 2 Switch off the engine. 3 Contact a qualified service technician for regeneration. <p>NOTE! Regeneration is only possible using Volvo's service tool.</p>
<p>Park machine Service needed Derate active</p>	<p>Warning, red</p>  <p>V1128638</p>	<ul style="list-style-type: none"> - buzzer sounds - red central warning on - engine performance is significantly reduced 	<ol style="list-style-type: none"> 1 Park the machine in a non heat sensitive area. Move the control lockout lever down to lock the system. 2 Switch off the engine. 3 Contact a qualified service technician to have the diesel particulate filter replaced. <p>NOTE! The soot load can only be reset by a qualified service technician.</p>
<p>Regeneration not needed</p>	<p>Warning, blue</p>  <p>V1088268</p>	<ul style="list-style-type: none"> - buzzer sounds - blue central warning on 	<ol style="list-style-type: none"> 1 No action required.
<p>Continue operation Low temperature Regeneration pending</p>	<p>Warning, amber</p>  <p>V1128635</p>	<ul style="list-style-type: none"> - buzzer sounds - amber central warning on 	<ol style="list-style-type: none"> 1 Continue operation.
<p>Service needed Regeneration not possible System failure</p>	<p>Warning, amber</p>  <p>V1128635</p>	<ul style="list-style-type: none"> - buzzer sounds - amber central warning on 	<ol style="list-style-type: none"> 1 Service required.



Operating instructions
170 Exhaust aftertreatment system



Emission compliance

The aftertreatment system is monitored by diagnostic systems in the control units to ensure reduced emissions. If the system does not meet the emission requirements, it should not be possible to use the machine for work as usual. This takes place by a reduction of engine power (derate).

Engine power is reduced if:

- The level in the AdBlue®/DEF tank is too low
- AdBlue®/DEF is of low quality
- There is a problem/malfunction with the aftertreatment system

There are two levels of engine power reduction (derate) that are activated after a certain time depending on the type of problem, as well as if the malfunction reoccurs or not.

Restoring engine function

If the engine is restarted (by turning the ignition off and on) when engine power has been reduced, then full engine power (called restored engine function) can be obtained twice during derate level 1. This can be done in case of a danger or hazard and, e.g., if the machine has to be moved. This will not extend the time for activation of derate level 2.









172 Operating instructions
Exhaust aftertreatment system

Exhaust aftertreatment system, alarms requiring special actions









NOTE!

The display text will show "AdBlue®" in machines for the European market and "DEF" in machines for the US market.

AdBlue®/DEF level monitoring		
Display figure	Alarm level	Action
—	- solid symbol	1 Turn off the engine. 2 Fill AdBlue®/DEF in the AdBlue®/DEF tank.
Refill AdBlue  V1126376 AdBlue empty Derate active	- buzzer sounds 4 times - amber central warning on  V1205598 - flashing symbol - torque reduction	1 Turn off the engine. 2 Fill AdBlue®/DEF in the AdBlue®/DEF tank.
Park safely  V1126376 AdBlue empty Full derate soon	- buzzer sounds continuously - red central warning on  V1205599 - flashing symbol - torque reduction	1 Turn off the engine. 2 Fill AdBlue®/DEF in the AdBlue®/DEF tank.
Refill AdBlue  V1126376 AdBlue empty Full derate active	- buzzer sounds continuously - red central warning on  V1205599 - flashing symbol - forced idle or torque and speed reduction (depending on market)	1 Turn off the engine. 2 Fill AdBlue®/DEF in the AdBlue®/DEF tank.













Operating instructions
Exhaust aftertreatment system 173

AdBlue®/DEF quality monitoring		
Display figure	Alarm level	Action
<p>Replace AdBlue</p>  <p>V1126376</p> <p>Wrong AdBlue quality Derate soon</p>	<ul style="list-style-type: none"> - buzzer sounds 4 times - amber central warning on  <p>V1205598</p> <ul style="list-style-type: none"> - solid symbol 	<p>Contact a qualified service technician.</p>
<p>Replace AdBlue</p>  <p>V1126376</p> <p>Wrong AdBlue quality Derate active</p>	<ul style="list-style-type: none"> - buzzer sounds 4 times - amber central warning on  <p>V1205598</p> <ul style="list-style-type: none"> - flashing symbol - torque reduction 	<p>Contact a qualified service technician.</p>
<p>Park safely</p>  <p>V1126376</p> <p>Wrong AdBlue quality Full derate soon</p>	<ul style="list-style-type: none"> - buzzer sounds continuously - red central warning on  <p>V1205599</p> <ul style="list-style-type: none"> - flashing symbol - torque reduction 	<p>Contact a qualified service technician.</p>
<p>Replace AdBlue</p>  <p>V1126376</p> <p>Wrong AdBlue quality Full derate active</p>	<ul style="list-style-type: none"> - buzzer sounds continuously - red central warning on  <p>V1205599</p> <ul style="list-style-type: none"> - flashing symbol - forced idle or torque and speed reduction (depending on market) 	<p>Contact a qualified service technician.</p>







Operating instructions
174 Exhaust aftertreatment system

SCR-system failure monitoring		
Display figure	Alarm level	Action
Check SCR-system  V1201756 SCR-system failure Derate soon	<ul style="list-style-type: none"> - buzzer sounds 4 times - amber central warning on  V1205598 <ul style="list-style-type: none"> - solid symbol 	Contact a qualified service technician.
Check SCR-system  V1201756 SCR-system failure Derate active	<ul style="list-style-type: none"> - buzzer sounds 4 times - amber central warning on  V1205598 <ul style="list-style-type: none"> - flashing symbol - torque reduction 	Contact a qualified service technician.
Park safely  V1201756 SCR-system failure Full derate soon	<ul style="list-style-type: none"> - buzzer sounds continuously - red central warning on  V1205599 <ul style="list-style-type: none"> - flashing symbol - torque reduction 	Contact a qualified service technician.
Check SCR-system  V1201756 SCR-system failure Full derate active	<ul style="list-style-type: none"> - buzzer sounds continuously - red central warning on  V1205599 <ul style="list-style-type: none"> - flashing symbol - forced idle or torque and speed reduction (depending on market) 	Contact a qualified service technician.
DPF-system failure monitoring		
Display figure	Alarm level	Action
Check DPF-system  V1201756 DPF-system deactivated	<ul style="list-style-type: none"> - buzzer sounds 4 times - amber central warning on  V1205598 <ul style="list-style-type: none"> - solid symbol 	Contact a qualified service technician.



Operating instructions
Exhaust aftertreatment system 175

<p>Check DPF-system</p>  <p>V1201756</p> <p>DPF-system missing</p>	<ul style="list-style-type: none"> - buzzer sounds 4 times - amber central warning on  <p>V1205598</p> <ul style="list-style-type: none"> - solid symbol 	<p>Contact a qualified service technician.</p>
<p>Check DPF-system</p>  <p>V1201756</p> <p>DPF-system failure</p>	<ul style="list-style-type: none"> - buzzer sounds 4 times - amber central warning on  <p>V1205598</p> <ul style="list-style-type: none"> - solid symbol 	<p>Contact a qualified service technician.</p>

Stopping

Stopping

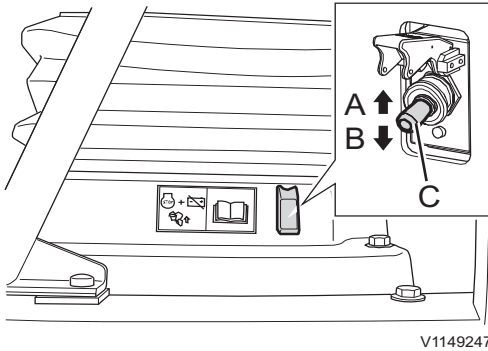

Battery disconnect switch

- A OFF position
- B ON position
- C Battery disconnect switch

- 1 Turn the mode selector on the right instrument panel to parking mode (P).
- 2 Reduce the engine speed to a minimum.
- 3 Make sure the control lockout lever is in locked position.
- 4 Leave the engine running at idling speed for approx. 30 seconds, before shutting off the engine. Otherwise the lubrication of the turbocharger may be jeopardised, resulting in shorter service life and great risk of bearing seizure.
- 5 Turn the ignition switch to OFF position (0).
- 6 Disconnect the battery by opening the red cover of the battery disconnect switch (C) and pressing the switch to the upper position (A).
Wait until the LED on the switch has turned off to be sure that the electronic system is completely shut down.

NOTICE

Wait until the electronic system is completely shut down before restarting.

For information about how to park the machine and how to minimise the burglary and theft risk see page 177.

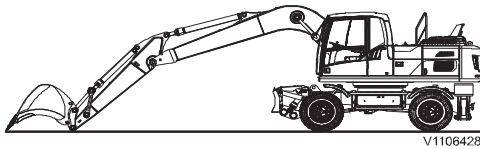

Parking position

V1106428

Parking

- 1 If possible, place the machine on level ground. If this is not possible, block the wheels so that the machine cannot start rolling.
- 2 Park the machine with the boom lowered and the piston rods of the attachment fully retracted. In this way they will be protected against moisture, dust and damage.
- 3 Check that all switches and controls are in the "off" position or in neutral.
- 4 Apply the parking brake after the machine has come to a complete standstill.
- 5 Turn off the engine and take out the ignition key.
- 6 Disconnect the battery pressing the battery disconnect switch in the upper position. Wait until the LED on the switch has turned off to be sure that the electronic system is completely shut down.
- 7 Check that there is enough anti-freezing solution in the cooling system (see page 301) and in the windscreen washer reservoir if the temperature can fall below $-20\text{ }^{\circ}\text{C}$ ($-4\text{ }^{\circ}\text{F}$) during parking.
- 8 Close and lock all windows, doors and covers.

WARNING

Risk of crushing.

Hydraulic or mechanical failure could cause the attachment to fall, resulting in severe personal injury or death.

Never leave the cab with a raised attachment. If a bucket is installed it must be resting against the ground.

Keep in mind that the theft and burglary risk can be minimised by:

- removing the ignition key when the machine is left unattended.
- locking doors and covers after working hours.
- turning off the current with the battery disconnect switch.
- avoid parking the machine with high risk of theft, burglary and damage.
- removing all valuables from the cab such as cellular phone, computer, radio and bags.
- chaining the machine.

By marking in the PIN-number or the national licence plate number of the machine on its windows, it is easier to identify stolen machines.

Long-term parking

NOTICE

If the machine is not used daily, the piston rods of the boom cylinders, which are not retracted, should be lubricated to protect them against corrosion.

- 1 Carry out the measures as described under parking.
- 2 Remember that the ground on which the machine is to stand may shift depending on weather, for example the machine can be frozen to the ground if standing in mud. Therefore take suitable action.
- 3 The temperature must not fall below $-40\text{ }^{\circ}\text{C}$ ($-40\text{ }^{\circ}\text{F}$) or exceed $+70\text{ }^{\circ}\text{C}$ ($158\text{ }^{\circ}\text{F}$).
- 4 Check that the batteries are fully charged.
- 5 Wash the machine and touch up the paint finish to avoid rusting.



- 6 Treat exposed parts with anti-rust agent, lubricate the machine thoroughly and apply grease to unpainted surfaces like lifting and tilting cylinders etc.
- 7 Check the machine for leakages or defect parts. Replace or repair all damaged or worn parts.
- 8 Check the tyre pressure and protect the tyres against strong sunlight.
- 9 Fill the fuel tank and the hydraulic oil tank to the max. marks.
- 10 Cover the exhaust pipe (parking out-of-doors).
- 11 Make sure that the freezing point of the coolant is sufficiently low (in cold weather).
- 12 When storing machines in extreme cold temperatures, remove batteries and store them at room temperature. Make sure to place the batteries over a wooden/plastic/rubber surface.

NOTICE

Start the machine for one hour once a month and run all cycles of functions to operating temperature.

Checks after long-term parking

- Check all oil and fluid levels.
- Check tension of all belts.
- Check air pressure.
- Check air cleaner.
- Check the batteries.
- Check hoses and seals for leakages.
- Check for damaged or worn parts.
- Check for foreign material on the machine.
- Lubricate all greasing points.
- Wipe off grease from piston rods.

If a preservative has been used on the machine to prepare it for long term storage, follow the manufacturer's instructions for any necessary safety precautions and the method of removal.



Retrieving and towing

Towing should only be performed to bring the machine out of a risk area and only if the engine is still running.

NOTE!

If the engine cannot be started, the brake and steering functions will be severely limited. In such cases, towing should only be performed in an emergency situation by experienced and trained personnel and only the shortest possible distance of at most 5 km (3 miles) and with a maximum towing speed of 10 km/h (6 mph). If possible, transport the machine on a trailer.

A manual release of the parking brake is necessary to tow the machine if the engine is not running. See page 180.

WARNING

Risk of serious accidents.

Uncontrolled swinging superstructure could cause serious injury or death.

Ensure the superstructure is secured before towing the machine.

WARNING

Risk of runaway machine.

Improper towing methods or faulty equipment could cause the machine to break away from the towing vehicle, causing accidents, serious injury or death.

Carefully follow the towing instructions and use only certified towing equipment with adequate load rating.

NOTICE

Only use the towing points intended for recovering and towing.

NOTE!

Before towing ensure that the towing linkage is properly connected, adequate for the purposes.

Operating instructions
180 Retrieving and towing

Only for machines with blade:

The cover on top of the blade must be taken away before towing to avoid scratches. Lift the cover up, take the cotter pin (B) and arrange the cover bracket that the cotter pin goes through the hole (A) in the cover bracket and the blade frame. Now as the cover bracket is in a fixed position, open the four screws (B) on top and remove the cover.

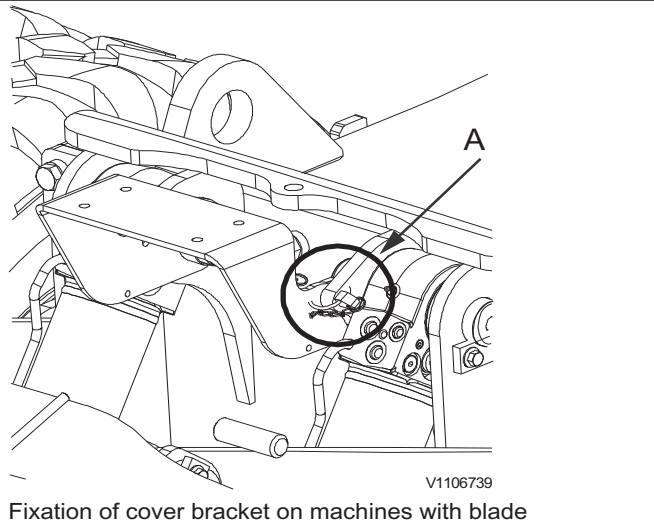

Fixation of cover bracket on machines with blade

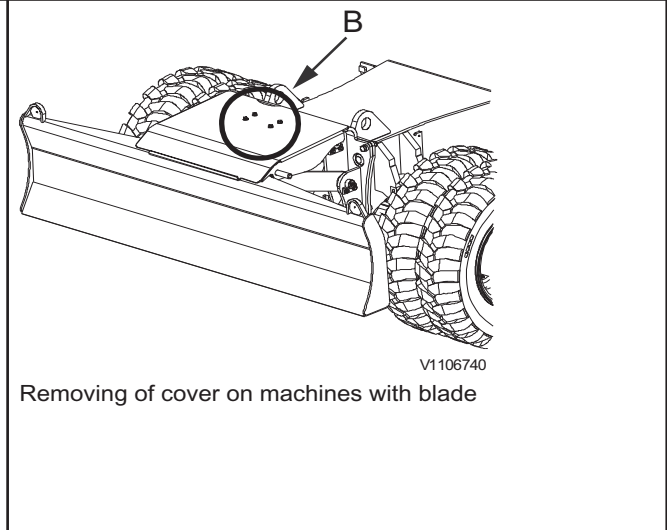

Removing of cover on machines with blade

NOTE!

Take care that the towing device is not scratching over any sharp edges, use a protection if needed.

To avoid oblique loading, pull the machine straight rearwards or forwards. Keep the towline angle as small as possible, maximum angle is 10°.

Maximum temporary force on the towing eyes must not exceed the following:

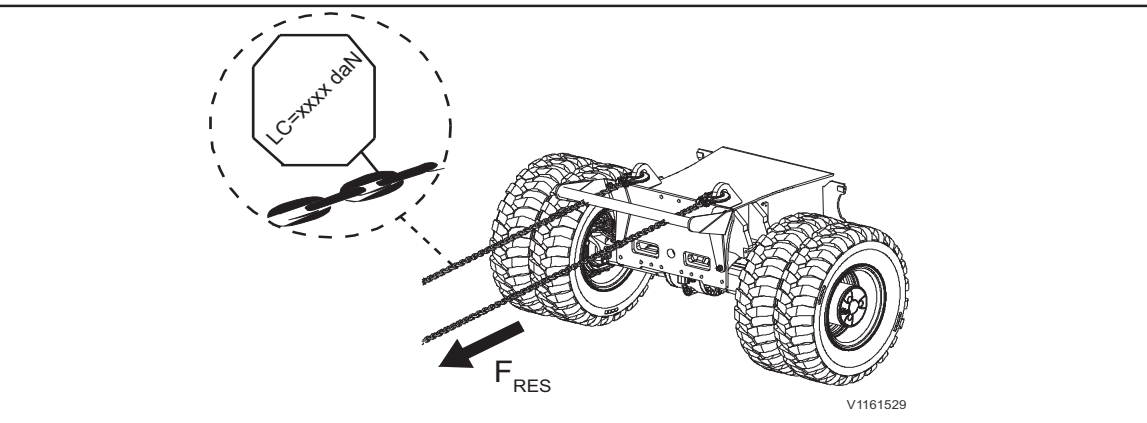

Direction	EW160E	EW180E
F_{Res} / LC (daN)	10350 daN	11050 daN
Maximum towing angle	10 °	10 °
1000kg = 9810N = 981daN = 9,81kN		
Load per device _ 2 devices are required for towing		

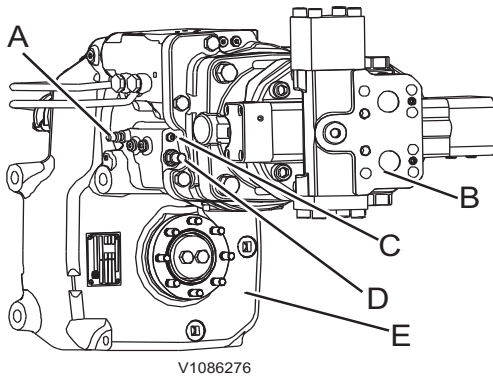

Gearbox

- A Bleed nipple
- B Travel motor
- C Grease nipple only for mechanical release of parking brake
- D Pressure relief valve
- E Gearbox

Parking brake, mechanical release

In case of no servo pressure or a defective travel motor, a manual release of the parking brake is necessary in order to enable to tow the machine.

Max. towing speed is 10 km/h (6 mph) and the max. towing distance is 5 km (3 miles). Exceeding the given limitations will lead to a damage of the gearbox due to lack of lubrication in the gearbox. In case of longer distance, the machine needs to be transported on a trailer.

WARNING

Risk of fatal accidents by runaway machine.

Manually releasing the parking brake could cause unexpected machine movement resulting in crushing injury or death.

Block the wheels before manually releasing the parking brake.

An emergency actuation on the gearbox shall only be done by mechanical personnel.

Activate emergency actuation on gearbox

- 1 Turn off the engine.
- 2 Choose P-mode.
- 3 Press grease into grease nipple (C) with a grease gun until it comes out at pressure relief valve (D).

Deactivate emergency actuation on gearbox

NOTE!

If the following procedure is done incorrectly the transmission could be damaged. This shall only be done by mechanical personnel.

- 1 Loosen bleed nipple (A).
- 2 Start the engine and select on-road gear (high speed). To release the emergency system from grease, a servo pressure of 30–35 bar (435–508 psi) must be applied.
- 3 Tighten the bleed nipple.
- 4 Collect the grease and clean around the nipple.

WARNING

Risk of fatal accidents by runaway machine.

Greasing the nipple for the mechanical parking brake release could cause unexpected machine movement resulting in crushing injury or death.

Never grease the grease nipple for mechanical parking brake release during machine maintenance.

Operating instructions
182 Retrieving and towing

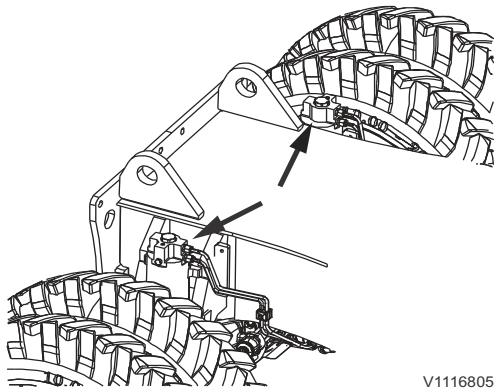

V1116805

Pivot axle lock cylinders

Pivot axle lock cylinder, manual release for towing

In case the engine is not running or if there is no servo pressure the pivot axle is locked and can only be released manually.

Never tow a machine long distance, max. 5 km with a max. speed of 10 km/h.

Releasing axle lock cylinders manually

A manual release of the axle lock cylinders shall only be done by mechanical personnel.

NOTE!

This procedure shall be done on both cylinders.

- 1 Turn off the engine.
- 2 Choose P-mode.
- 3 Clean the area around the plug (1) and the air vent (2).
- 4 Place a container under the cylinder to collect any oil spills.
- 5 Loosen the air vent (2) with 2–3 turns to release the encased pressure.
- 6 Remove the plug (1) carefully.
- 7 Remove the spring (3) and store it clean.
- 8 Reinstall the plug (1) with a tightening torque of 235–265 Nm (173–195 lbf ft).
- 9 Tighten the air vent (2).

NOTE!

After towing, the cylinders have to be restored.

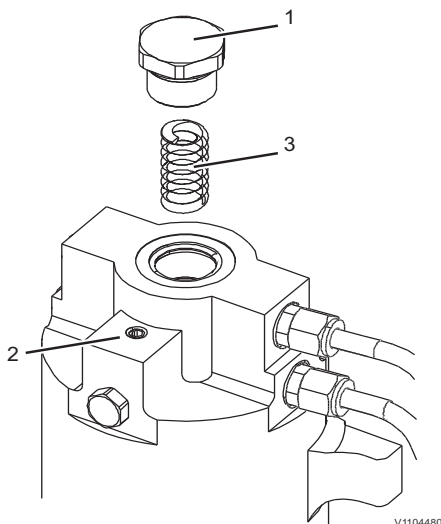

V1104480

Pivot axle lock cylinder, spring removal

- 1 Plug
- 2 Air vent
- 3 Spring

Attachments, alternative lowering

WARNING

Risk of high pressure injection.

The hydraulic oil is under high pressure and will cause serious injury when injected into the skin.

Keep away from oil that is spraying out. Use cardboard or similar for locating leaks. Do not use your hands to locate leaks.

Alternative lowering with servo pressure

As long as there is servo pressure in the accumulators, the attachment can be lowered even if the engine or servo pump are not functioning. In case of an engine stop, lower the attachment immediately, while there is servo pressure in the accumulators.

- 1 Turn the ignition switch to operating (preheating) position (1) and move the control lockout lever to the unlocked position.
- 2 Operate the attachment slowly downward until it rests on the ground.

WARNING

Risk of burns.

Hot oil can cause severe burns to unprotected skin.

Always wear personal protective gloves, goggles and clothing when handling hot oil.

NOTE!

Hydraulic oil is hazardous to the environment. Immediately use barriers to contain spilled oil and follow local regulations concerning hazardous materials.

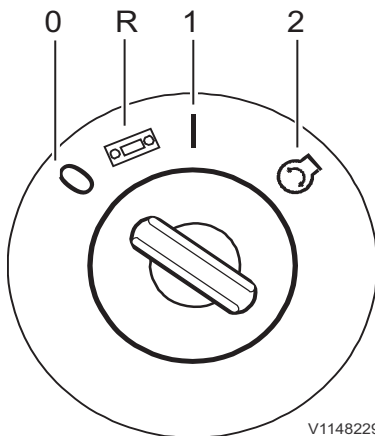

V1148229

Ignition switch

- OFF position (0)
- Radio position (R)
- Operating (preheating) position (1)
- Start position (2)

Operating instructions

184 Attachments, alternative lowering

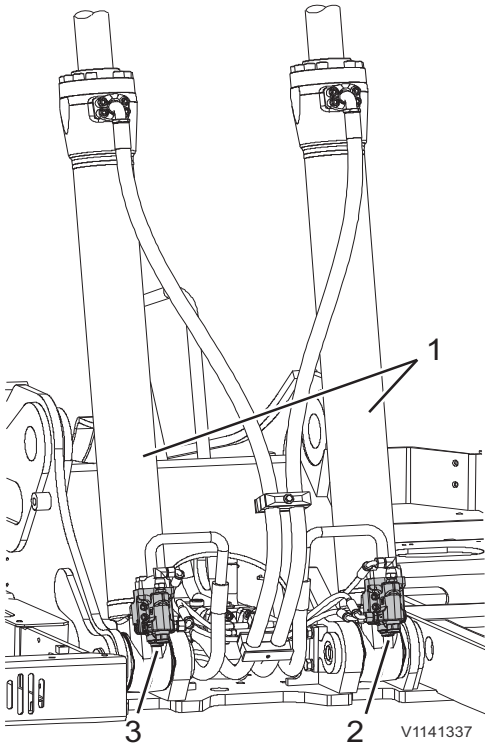

Line rupture valves on boom cylinder

- 1 Boom cylinder
- 2 Line rupture valve left
- 3 Line rupture valve right

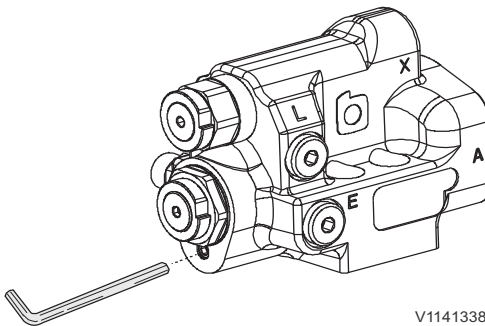

Adjusting screw on line rupture valve

Alternative lowering without servo pressure (with line rupture valves)

It is not possible to lower the attachment with the control lever if the servo pressure has been lost. In such cases the attachment should be lowered by opening the oil channel from the boom cylinders to the tank (secondary lowering) as follows.

! WARNING

Risk of crushing.

Incorrect function of the line rupture valves may cause uncontrolled lowering of the attachment.

Do not enter under the attachment when working with the alternative lowering function.

- 1 Use a 4 mm allen key, select one line rupture valve and turn the screw counterclockwise until the boom starts lowering. The screw cannot be completely unscrewed.
- 2 Lower the boom to the required position.
- 3 Tighten the screw again to restore the valve's function. Tightening torque: 7 Nm (5.2 lbf ft)

Line rupture valves

Line rupture while raising or lowering the boom

The two interconnected line rupture valves are mounted directly on the boom cylinder bottom sides. The main function of the valves is to prevent the boom from making an uncontrolled movement towards the ground in case of a line rupture between the main valve block MCV and the line rupture valves.

If the line ruptures while raising the boom, the pressure disappears immediately, the non-return valve closes and the movement of the boom stops.

If there is a line rupture while lowering the boom, this will limit the increase of the lowering speed within the control range. The movement of the boom can be stopped or continued, as if the line had not ruptured. When the boom is lowered, after a line rupture, the oil has to be collected in a suitable vessel.



Operating instructions

Attachments, alternative lowering

185

! WARNING

Risk of burns.

Hot oil can cause severe burns to unprotected skin.

Always wear personal protective gloves, goggles and clothing when handling hot oil.

NOTE!

Hydraulic oil is hazardous to the environment. Immediately use barriers to contain spilled oil and follow local regulations concerning hazardous materials.

Servicing line rupture valves

Any service on the line rupture valves must be done by a qualified service technician.

! WARNING

Risk of serious injury.

A valve under pressure could result in serious injury.

Do not disassemble the line rupture valves, contact a qualified service technician.

A line rupture valve may be under pressure from the oil in the boom cylinder, even if the rest of the hydraulic system is without pressure.

A pressurised line rupture valve must never be removed as its content will shoot out with great force and may injure persons in the vicinity.

Transporting machine

Measurements before transporting machine

NOTICE

The person in charge of the transport must see to that loading, positioning, lashing and transporting the machine on a trailer or other vehicle is done according to applicable laws and regulations for the country or state in question. For further information, contact your dealer.

Inspections and actions before transport:

- Inspect lifting or tying-down attachment points on the machine and the trailer for wear and damage before transport and at each service. If they are worn or damaged they must be replaced before transport.
- Choose adequate lashing equipment according to the tables on the next pages.
- Inspect lashing equipment before use. If it shows signs of wear or damage it must not be used, replace it immediately.
- Check that the loading surface of the trailer is free of oil, dirt and ice.
- Clean the machine from mud and stones to avoid pollution on the road and damage on other vehicles.
- Fold down or remove antennas and the rotating beacon on the machine.
- Do not move the machine before you know how to operate the steering and the control system.

NOTE!

Various steering options are available, for information about the Comfort Drive Control (CDC) see page 160.

- Engage the pivot axle locking and swing brake on the machine before loading on the trailer, see page 150
- Make sure that all covers and doors on the machine are locked before starting the transport.

WARNING

Risk of crushing injury.

The hydraulic system could respond slowly at low temperatures and could cause unexpected machine movements.

Operate carefully until the hydraulic system has reached operating temperature.

Tying down machine

Both the front and the rear of the undercarriage must be lashed down. Tie the machine down using attaching points. Links can be secured to the attachment at the arm or the bucket. The links must be thoroughly tightened, with, for example, turnbuckles. Blocks must be placed in front of and behind each wheel.

Buckets or other types of attachments need to be secured separately.

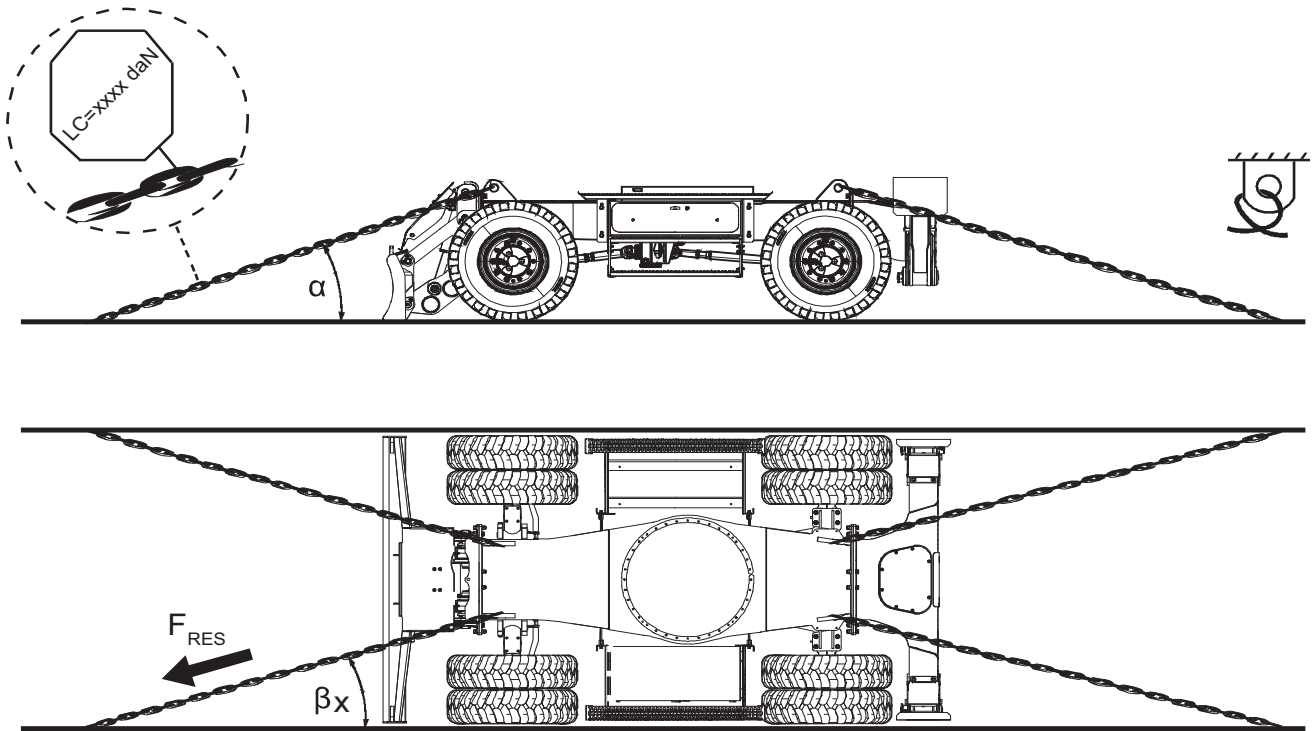

V1185216

Use 2 lashings on front and 2 on the rear of the machine as shown on the picture.
Cross lashing is permitted if angle areas are not exceeded.



Operating instructions
188 Transporting machine

Tying down machine for road transport		
Model	EW160E	EW180E
Friction coefficient (μ)	0.2 μ (rubber tyres on dirty and wet steelsurface)	
F _{RES} / LC (daN)	10200 daN	11000 daN
Angle α (°)	15 ° – 45 °	15 ° – 45 °
Angle β_X (°)	15 ° – 35 °	15 ° – 35 °
Friction coefficient (μ)	0.5 μ (with rubber anti slip mat on contact areas)	
F _{RES} / LC (daN)	6000 daN	6000 daN
Angle α (°)	15 ° – 45 °	15 ° – 45 °
Angle β_X (°)	15 ° – 35 °	15 ° – 35 °
1000 kg = 9810 N = 981 daN = 9,81 kN		
4 tying down devices are required Do not exceed angle areas!		

Tying down machine for rail transport		
Model	EW160E	EW180E
Friction coefficient (μ)	0.2 μ (rubber tyres on dirty and wet steelsurface)	
F _{RES} / LC (daN)	12200 daN	13000 daN
Angle α (°)	15 ° – 45 °	15 ° – 45 °
Angle β_X (°)	15 ° – 35 °	15 ° – 35 °
Friction coefficient (μ)	0.5 μ (with rubber anti slip mat on contact areas)	
F _{RES} / LC (daN)	8000 daN	8000 daN
Angle α (°)	15 ° – 45 °	15 ° – 45 °
Angle β_X (°)	15 ° – 35 °	15 ° – 35 °
1000 kg = 9810 N = 981 daN = 9,81 kN		
4 tying down devices are required Do not exceed angle areas!		

Tying down machine for sea transport		
Model	EW160E	EW180E
Friction coefficient (μ)	0.2 μ (rubber tyres on dirty and wet steelsurface)	
F_{RES} / LC (daN)	14000 daN	15000 daN
Angle α ($^{\circ}$)	15 $^{\circ}$ – 45 $^{\circ}$	15 $^{\circ}$ – 45 $^{\circ}$
Angle β_X ($^{\circ}$)	25 $^{\circ}$ – 35 $^{\circ}$	25 $^{\circ}$ – 35 $^{\circ}$
Friction coefficient (μ)	0.5 μ (with rubber anti slip mat on contact areas)	
F_{RES} / LC (daN)	8000 daN	8000 daN
Angle α ($^{\circ}$)	15 $^{\circ}$ – 45 $^{\circ}$	15 $^{\circ}$ – 45 $^{\circ}$
Angle β_X ($^{\circ}$)	25 $^{\circ}$ – 35 $^{\circ}$	25 $^{\circ}$ – 35 $^{\circ}$
1000 kg = 9810 N = 981 daN = 9,81 kN		
4 tying down devices are required Do not exceed angle areas!		

Temporary force on the towing hook on outrigger		
Model	EW160E	EW180E
Direction		
F_X	12300 daN	12300 daN
F_Y	1000 daN	1000 daN
1000 kg = 9810 N = 981 daN = 9,81 kN		
Load on pull pin device.		

Counterweight

WARNING

Risk of crushing!
Incorrect handling of counterweight could cause serious crushing injury or death.

Never remove or install the counterweight by yourself!
Always contact a qualified service technician to remove or install the counterweight.

When removing/installing counterweight – contact a qualified service technician.

190 Operating instructions
Transporting machine

Lifting machine

! WARNING

Risk of personal injury.
Faulty or improper lifting equipment could cause the machine to break away from the lifting vehicle, causing accidents, serious injury or death.

Use certified cables, lifting straps, slings, shackles and hooks with adequate load capacity and never lift the machine with a person in or on the machine.

NOTE!

Lift the machine on flat, even and level ground.

NOTE!

Only use the lifting points intended for lifting and do not use the lifting eyes to lift more than the total machine weight.

- 1 Start the engine, and arrange the bucket, arm and boom as illustrated below.
- 2 Move the control lockout lever down to lock the system securely.
- 3 Stop the engine, check the safety around the machine.
- 4 Close and lock windows, doors and hoods securely.
- 5 Remove the covers from the lifting points on top of the counterweight.
- 6 Attach the lifting slings according to the decal on the right side of the cab.
- 7 At the beginning of the lift, check that the machine is level before continuing the lift.
- 8 Maintain good visibility of the machine at all times during the lift. And continuously check that the machine is level.

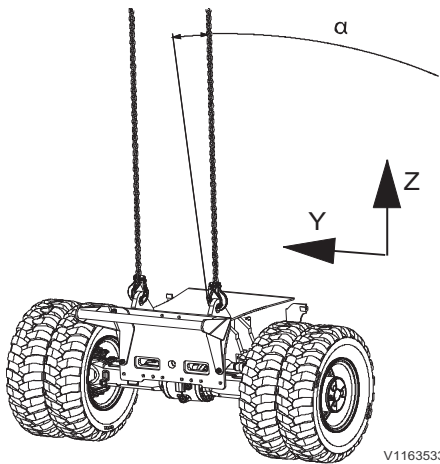

V1163533

Lifting		
Direction	EW160E	EW180E
F _{Res} / LC (daN)	5250 daN	5600 daN
Angle α max.	15 °	15 °
1000kg = 9810N = 981daN = 9,81kN		
Load per device _ 4 devices are required for lifting		

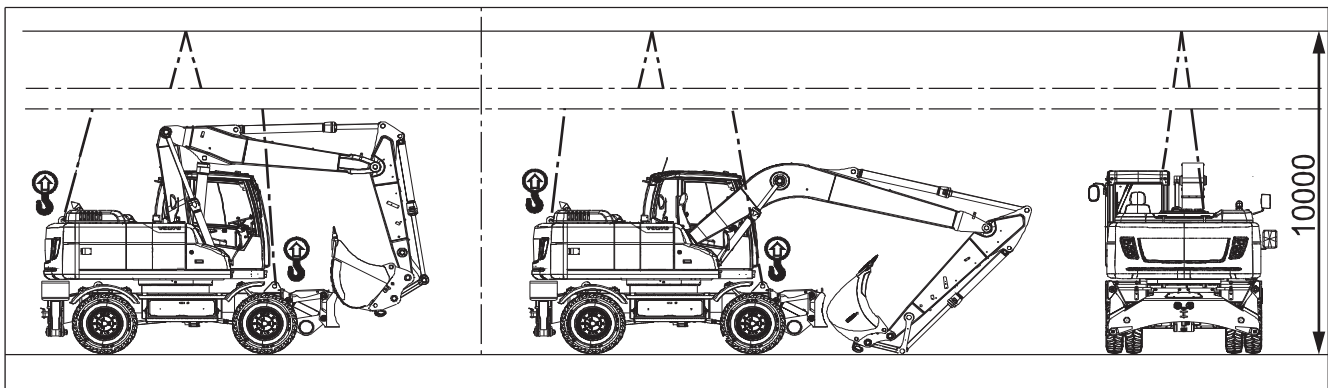

V1101213



Operating techniques

The excavator is a multi-task machine capable of being fitted with multitude special attachments to perform many types of work. This chapter contains information and instructions regarding the best operating practices to improve efficiency, including examples on how the most common attachments are used. It is important that the correct technique is used to obtain safe and efficient use of the machine.

This machine is equipped with load-sensing hydraulics, which means that the oil in the system is supplied proportionally according to the position (deflection) of the control levers. If the control levers are in neutral position, consequently no oil is supplied from the pumps.



Eco driving

ECO mode function

The ECO Mode function is an assistant system to reduce fuel consumption and noise during working and travelling by reducing the engine speed. The ECO mode is activated automatically each time you start the machine and a sign is visible in the display.

In the ECO Mode the engine speed you select on the mode selector in W- and C-Mode is reduced. Also the maximum engine speed in T-Mode is reduced accordingly. The idle speed remains unchanged.

It can be turned off and on again at any time on the keypad by pressing the ECO button, see 80, if it is turned off the display sign disappears.

Operating behaviour

To utilise the system in the best way and at the lowest fuel consumption, the engine speed should be kept low during all operations. The lifting speed and force are sufficient already at a low engine speed, which will result in a lower fuel consumption, lower sound level and a higher degree of comfort, but in many cases sufficient productivity level. Operating to reduce fuel consumption also lowers wear on the machine and is environmental friendly. Additionally to the ECO mode function also the operating behaviour has an influence on economical machine operating.

Always try to:

- 1 Avoid unnecessary machine motions.
- 2 Plan your work site.
Take stock of your work area and plan its layout with regard to the machines that will work there, your work will be much more productive and organized. Keep the ground even and free from larger stones or other objects that form obstacles.
- 3 Cooperate
Consult with other operators so that machines and trucks work together in the most effective way.
- 4 Use the right equipment.
The right equipped machine saves on fuel and maintenance. See this chapter for further information about equipment.
- 5 Use the correct tyre pressure, see 344

Contact your local Volvo Construction Equipment dealer for further information and the possibility to attend a Volvo training for fuel efficient machine operating.



Whole-body vibrations

Whole-body vibration emission on construction machinery are affected by a number of factors, such as working mode, ground conditions, speed, and so on.

To a large extent the operator can influence the actual vibration levels, because the operator controls the speed of the machine, its working mode, the travel path, and so on.

Therefore, the result can be a range of different vibration levels for the same type of machine. For cab specifications, see page *Cab*.

Guidelines for reducing vibration levels on earthmoving machines

- Use the proper type and size of machine, with optional equipment and attachments for the application.
- Keep the terrain and haul roads in good condition.
 - Remove any large rocks or obstacles.
 - Fill any ditches and holes.
 - Provide equipment and schedule time to maintain terrain conditions.
- Adjust the speed and travel path to minimize the vibration level.
 - Drive around obstacles and rough terrain conditions.
 - Reduce the speed when it is necessary to go over rough terrain.
- Maintain machines according to the manufacturer's recommendations.
 - Track tensions. (crawler machine only)
 - Tire pressures. (wheel machine only)
 - Brake and steering systems. (wheel machine only)
 - Controls, hydraulic system and linkages.
- Keep the seat maintained and adjusted.
 - Adjust the seat and its suspension according to the weight and size of the operator.
 - Inspect and maintain the seat suspension and adjustment mechanisms.
 - Use the seat belt and adjust it correctly.



194 Operating techniques Whole-body vibrations

- Steer, brake, accelerate, shift gears, and move the attachments smoothly. (wheel machine only)
- Minimize vibrations for long work cycle or long distance travelling.
 - Use suspension systems if available.
 - If no suspension system is available, reduce speed to prevent bouncing.
 - Transport machines when there are long distances between worksites.

Back pain associated with whole-body vibrations may be caused by other risk factors.

The following guidelines can be effective to minimize risks of back pains:

- Adjust the seat and controls to achieve good posture.
- Adjust the mirrors to minimize twisted posture.
- Provide breaks to reduce long periods of sitting.
- Avoid jumping down from the machine.
- Minimize repeated handling and lifting of loads.
- Maintain reasonable weight and physical condition.

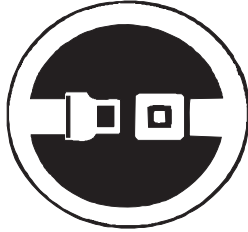

V1086032

Always use the seat belt.

Rules for digging

WARNING

Risk of serious injury.

More than one person in the cab while operating could cause accidents and serious injury.

Only the operator, seated in the operator's seat, may be in the cab when operating. All other persons must keep at a safe distance from the machine.

First read the safety rules for operating, see pages 146, 146, 147, 147 and 148.

- Always prepare work by carefully studying drawings and regulations that apply to the site. Also study the ground conditions and what the risk areas on the site look like. Turn off gas, electricity and water supplies, if this is necessary. Mark the position of cables and pipes.
- Fence off the area around the machine, if there is a risk that people may get too close. Pay attention to a swinging machine.
- Look after your workmates! Make sure that they take care. No persons, apart from the operator, may be present within the working area of the machine. Teach them to be on their guard against collapsing banks and rolling stones and to be prepared to dash for safety. Changes in stress in a bank immediately prior to a landslip are indicated by small streams of loose material just where the cracks are forming.
- If the machine is provided with optional equipment, which is operated with the pedals or control levers, the operator must assure him or her self of that the anticipated movements are obtained when actuating the pedals. An unexpected movement may entail risk of an accident.
- A cab provided with protective grill over the roof window meets the requirements for falling object guard in accordance with stated testing methods (FOPS/ISO 3449). Use the falling object guard when there is risk of heavy, falling objects.

NOTICE

With certain attachment combinations there is a risk that the attachment may strike the cab. Avoid damage by being careful when working close to the machine.

- Before beginning to dig, apply the digging brake, see page 164.
- Work with the excavator unit over the rear axle. The machine capacity is then utilised most efficiently.
- The machine must not be equipped with a larger bucket/attachment than permitted.
- Take care when digging, the teeth on the bucket may damage the tyres.
- When digging at great depth, there is a risk that the boom cylinders or the cylinder operating the two-piece boom may be damaged against the undercarriage. Operate with care when digging in great depth to avoid that the cylinders striking the undercarriage.
- Lower stabiliser legs / stabiliser blade for best stability.
- If uncontrolled movements should occur, first release levers and pedals, then pull the release lever to put the control lockout lever in locked position and then shut off the engine

immediately by turning the ignition switch to the OFF position (0).

- If a red warning lamp lights up and/or the buzzer sounds, stop the engine immediately and investigate the cause.
- In case of fire, the battery disconnect switch should be turned off if possible.

While working, do not:

- swing the bucket or load above people.
- use the bucket or other attachment for chopping.
- extend the hydraulic cylinder to its end of stroke. This can overload the stop in the cylinder and shorten the life span of the machine. Work with as much clearance as possible.
- operate closer than 10 cm (4 in) from the hydraulic cylinders end-of-stroke positions when using equipment which generate knocks or vibrations, e.g. hammer.
- use the swing force for raking over the ground, demolition of buildings or thrusting bucket teeth into the ground. It may cause damage to the machine and attachments.
- work by slamming the bucket into the ground. Do not perform digging by dropping the boom, or using the bucket instead of a pick. Striking digging or continuous striking can overload the rear of the machine or damage the attachment. It is also very dangerous.
- carry out lifting work. Basically, using this machine as a crane is prohibited. However, local or national regulations may allow it on some markets. If permitted, a properly installed rated bucked hook and certified slings / shackles are required. Contact an authorised dealer for more information.

Loading on to a vehicle

- If possible, position the machine higher than the vehicle to be loaded.
- Place the vehicle to be loaded so that the machine does not have to swing and lift more than necessary.
- Make sure that the operator of the vehicle to be loaded stays outside the working area of the machine and never swing the bucket over the cab of the vehicle to be loaded.
- Do not load the vehicle unevenly and avoid unnecessary spillage when loading. Do not make the load so high that earth and stones fall over the platform sides.
- Place large stones on a layer of finer material at the rear of the platform, so that the platform is not damaged when dumping the load.
- Release the load carefully.

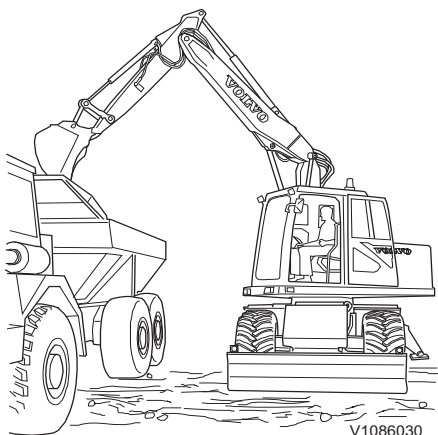

WARNING

Risk of crushing.

Material may fall off when loading a vehicle.

Make sure that no persons are standing near the vehicle while loading.

Boom Suspension System (BSS)

Boom Suspension System (BSS)

(Suspension of digging equipment / optional equipment)

The boom suspension system absorbs shocks when travelling across uneven ground. This increases the operator comfort and the stability of the machine.

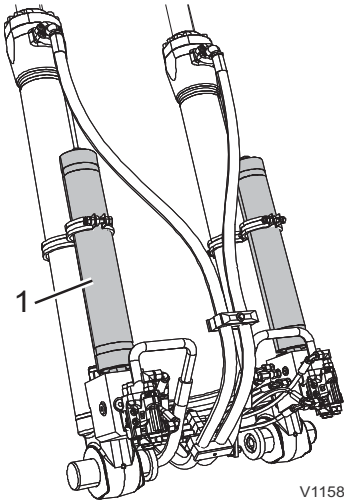

V1158560

- 1 Boom suspension accumulators on two-piece boom

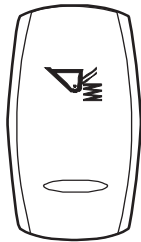

V1091822

BSS switch



V1069834

BSS symbol in the display

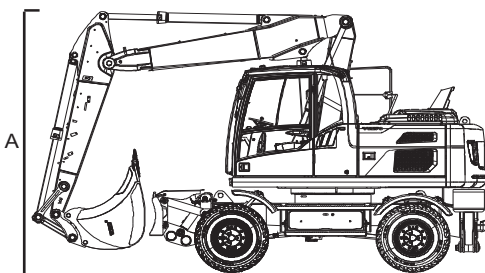

V1128262

Travel position with BSS (two-piece boom)
A Maximum machine height of 4 m (13 ft 1,5 in)

Engaging the boom suspension system

Press the upper end of the BSS switch down to engage the system.

The BSS symbol appears in the display.

- BSS symbol yellow: BSS preparation
- BSS symbol green: BSS is active

NOTE!

The boom can move slightly up or down when engaging the system.

The BSS activating speed value in W- and C- mode is by default 5 km/h (3,11 mph), below that speed the system is deactivated. In T-mode the activation is not speed related.

When selecting T-mode and the superstructure is aligned with the undercarriage, the boom suspension system will stay active all the time.

NOTE!

The activation speed for W- and C-mode is adjustable by a parameter, this can only be done by a service technician.

Travel position with BSS

A maximum machine height of 4 m (13 ft 1,5 in) must not be exceeded when travelling on public roads.

The travel position with the boom suspension varies from the normal travel position: The boom cylinder must not be fully extended, it should remain slightly below the end stop position.

NOTE!

With the boom suspension system the attachment can swing up or down. The operator must take care for the maximum machine height.



Operating techniques
198 **Boom Suspension System (BSS)**

Disengaging the boom suspension system

To disengage the boom suspension system press the lower end of the BSS switch down. The BSS symbol is not shown in the display if the system is switched off.

Working within dangerous areas

NOTE!

The machine operator is responsible for being aware of and complying with the relevant, legally prescribed, national and regional safety instructions. These special instructions for working within dangerous areas are applicable only in cases where no specific legislated safety instructions are in force.

- Observe great care at marked danger areas.
- Do not operate too close to the edge of a quay, ramp, and so on.
- Move slowly when working in confined spaces and check that there is sufficient room for machine and load.
- When working under ground, special equipment, for example certified engine is required within the EU and in EES countries. Talk to your dealer.
- When working in low light conditions, for example buildings and tunnels, use head lights (optional equipment).
- Do not operate the machine when visibility is poor such as a heavy fog, snow or rain.
- When working in an area which is contaminated or dangerous to one's health, the machine must be especially equipped for this purpose. Talk to your dealer. Check also local regulations before entering the area.

High voltage overhead power line



Always contact the facility owner before working near a high-voltage facility.

DANGER

Risk of electrocution

Working near or making contact with overhead power lines may lead to electrical flashover and electrocution.

Always keep the minimum clearance from overhead power lines.

High voltage is lethal and may be powerful enough to destroy both the machine and attachment. Always contact the responsible power company before starting to work near high voltage power lines. Review the special instructions that the power company has issued for working or being close to power lines.

Consider all power lines to be 'live' with electric power, even those that are supposed to be without electric power. At any time, working when the machine or its load is closer to the power line than the minimum safety distance entails a very serious risk, see the table below.

Voltage Volt (V)	Distance	
	m	ft
~50,000	3	10
50,000~69,000	4.6	15
69,000~138,000	5	16.4
138,000~250,000	6	20
250,000~500,000	8	26
500,000~550,000	11	35
550,000~750,000	13	43
750,000~	14	46



- Remember that the voltage in the power line determines the safety distance. Electrical flashovers may damage the machine and injure the operator at relatively great distances from the power line.
- Find out what actions need to be taken if an operator has been exposed to an electrical flashover.

NOTICE

Also when transporting the machine, take overhead power lines into consideration.

Railroad overhead contact system

Keep in mind that the power lines for the adjacent tracks may also be live.

Loading and unloading is only permitted between the designated limit signs. The signs may be installed on the contact line or on special posts.

- Contact authorised railroad personnel for permission to load or unload.
- After a break in the work, always take new contact with railroad personnel.



Underground cables and pipes

Make sure that authorities or companies responsible for cables and pipes have been contacted and that their instructions are followed. Also check which rules apply to ground personnel regarding exposing cables and pipes. Normally only the service companies' own personnel may expose and arrange provisional suspension of cables.

Make use of a signal man when you cannot see the actual point where you are working or when the position of the pipe or cable is critical, see page 243. The position of the pipe or cable may deviate from the drawing or distances may be incorrectly determined. Regard all electrical cables as live.

Working on slopes

NOTICE

In order not to jeopardise the lubrication of the engine, the machine must not be inclined more than 35 degrees in either direction. In addition it may be unsuitable to operate at this inclination as the machine may become unstable and unbalanced, depending on the load.

- Be careful when opening or closing the doors on a slope, operational force may be changed rapidly. Make sure to keep the doors closed.
- Do not descend backward on a slope.
- Make sure to keep the doors closed. Do not descend backward on a slope.
- Operate the travel function slowly when approaching or descending a slope.
- Do not change direction or travel across on a slope. Change direction on level ground, if necessary first come down to level ground and make a detour.
- If the machine slides, immediately lower the bucket to the ground. The machine can turn over due to unbalance. Especially, do not swing with loaded bucket. In unavoidable case, pile up earth on the slope, and then make the machine level and stable.
- While travelling on a slope, keep the angle between boom and arm at 90–110°, raise the bucket 20–30 cm (8–12 in) from the ground.
- If the engine shuts down on a slope, lower the attachment to the ground. Do not operate the swing function since the upper structure may be swung under its own weight and cause tipping or side slipping.

NOTE!

Keep in mind while working on a slope that the lifting charts are only valid if the machine is placed on firm level ground. Also the liability of the overload function is limited if the machine is standing in a slope.

Working in water and on boggy ground

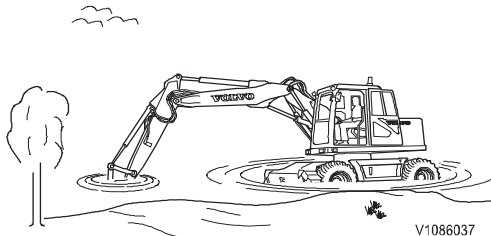

V1086037

When wading with the machine across a water course, use the bucket as a "feeler" if the water is muddy. The water course may have hidden obstacles under the surface or the depth may change suddenly, endangering the operator and the machine. While wading, stop the machine now and then and swing the bucket sideways just above the bottom. This operation reveals stones or other obstacles. Prod the bottom with the bucket to measure the depth in order to discover any dangerous hollows.

- After working in water, the lubrication points on the undercarriage, which have been under water, must be lubricated, so that the water is driven out. Check also that no water has entered the travel gearbox and axles.



NOTICE

Do not exceed the maximum permissible water depth. The water must not reach higher than the middle of the wheel.

- Heavy timber mats can be used to support the machine when working on boggy ground. The mats should be kept as flat and clean as possible.

Working where there is risk of landslip

Always check ground conditions before beginning to work. If the ground is soft, great care must be taken when positioning the machine. Thawing of frozen ground, rain, traffic, piling and blasting are factors which increase the risk of landslip. The risk also increases on sloping ground. If it is not possible to dig with sufficiently slanting trench sides, the machine must be shored up.

- Do not place excavated material too close to the edge as its weight may cause a landslip. Loose clay should be placed at least 5 m (16 ft) away from the edge.
- Do not dig under the machine.
- Do not operate too close to the edge of a steep slope or road bank. Take care when working in a place where the machine may tip.
- Dig with the excavator unit over the rear axle, with the stabiliser legs / stabiliser blade down. In this way the greatest stability is obtained and the machine will be easy to drive away.
- Take care when working on river banks or in other similar places where the ground is soft. There is a risk that the machine, because of its own weight and own vibrations, may sink and this could lead to accidents.
- Keep in mind that the ground conditions may have changed after heavy rain. Therefore, be careful when restarting work. This is particularly important when working near the edge of ditches, road verges or similar, as the ground may easily give way after it has been raining.

Working in cold weather

DANGER

Risk of electrical shock.

Personal injury results if a body part comes into contact with a machine that conducts electric power.

Disconnect the electrical engine heater before working on the machine.

WARNING

Risk of frostbite.

Bare skin can freeze stuck to cold metal which could cause injury. **Use personal protective equipment when handling cold objects.**

WARNING

Risk of crushing injury.

The hydraulic system could respond slowly at low temperatures and could cause unexpected machine movements.

Operate carefully until the hydraulic system has reached operating temperature.

Read the advice for starting, see page 153.



204 Operating techniques Working within dangerous areas

The windows must be free from ice and snow before putting the machine to work.

- Watch out for ice on the machine causing slippery conditions. Step only onto anti-slip surfaces.
- Use an ice scraper on a long handle or a ladder when removing ice from the windows.

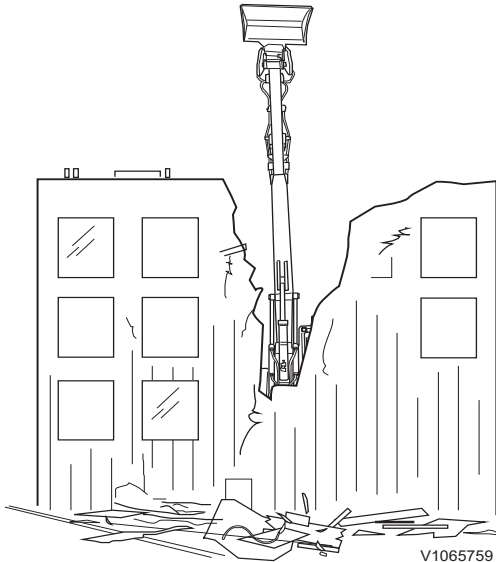

V1065759

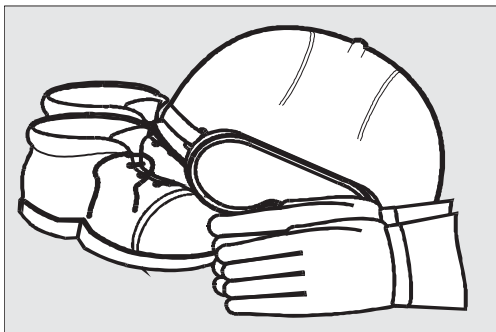

V1067189

Demolition work

The machine is often used for demolition work. Be extremely careful and study the work site thoroughly. Use fall protection over the cab against falling objects.

- Make sure that the material, on which the machine is standing, cannot collapse or slide.
- Operate the machine on firm level ground, if necessary prepare the area with another machine first.
- Do not work close to free-standing walls, which may fall over the machine.
- At all times be aware of where your workmates are. Do not work if anyone is dangerously close to the demolition object.
- Leave sufficient space in front of the machine for debris to fall to the ground and not hit the cab.
- Fence off the dangerous part of the work site.
- Spray water over the demolition site to prevent harmful dust from spreading.

Boots with steel reinforcements in the soles and toe caps, protective goggles and a hard hat are obvious protective items to be worn on a demolition site.

If the machine is equipped with special demolition equipment, read the supplied instruction booklet about the safety risks that might occur and how the demolition equipment is used.

206 Operating techniques
Working within dangerous areas

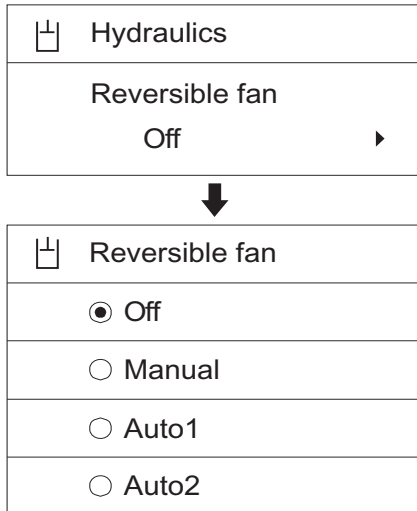

V1137864



V1068779

Reversible fan

(Optional equipment)

The reversible fan is designed to clean the cooling module (clogging net, radiator and oil cooler fins), maintain the cooling performance and also extend the cleaning interval.

Modes and setting

The reversible fan is set up by the IC (Instrument Cluster) menu as one of "Off", "Manual", "Auto1", "Auto2" mode. It also allows the operator to select a reversible fan mode. The "Off" mode is set up as default initially.

- **Off mode:** Maintain normal rotation or revert to "Off" mode by stopping reverse rotation. Also selecting the "Off" mode during the "Manual" mode cancels the reverse rotation and returns to previous setting mode.
- **Manual mode:** Reverses the rotation one cycle immediately after setting the mode. After finishing the "Manual" mode, returns to the previous setting mode. Reverse rotation time is set up as 60 seconds and changeable between 20 to 180 seconds by Volvo's service tool. Contact a qualified service technician.
- **Auto1 mode:** Repeats a cycle consisting of normal rotation and reverse rotation. Normal rotation time is set up as 60 minutes and changeable between 5 to 120 minutes by Volvo's service tool. Contact a qualified service technician. Reverse rotation time is set up as 20 seconds and not changeable.
- **Auto2 mode:** Repeats a cycle consisting of normal rotation and reverse rotation. Normal rotation time is changeable between 5 and 20 minutes. Reverse rotation time is set up as 20 seconds and not changeable.

NOTE!

The reversible fan indicator is shown on the indicator screen of IC (Instrument Cluster) during reverse rotation.

NOTE!

When operating in travel mode the reversible fan is automatically deactivated.



Attachments

WARNING

Risk of fatal accidents.

Using attachments for lifting or transporting persons may lead to fatal accidents with serious crushing injury or death.

Never use attachments for lifting or transporting persons.

Using the correct attachment for a particular job is a deciding factor when it comes to the capacity of the machine.

The machine has either direct-mounted attachments or attachments mounted with a hydraulically controlled quick coupler which allows rapid changes of attachments.

Always follow Volvo recommendations when choosing attachments. If other attachments are used, follow the Operator's manuals from the respective suppliers.

It is the responsibility of the machine owner to make sure that these attachments are approved for mounting on the machine. The machine owner is responsible for the safety of the combination machine – attachment.

For more detailed information regarding the choice of attachments, contact a Volvo Construction Equipment dealer.

The machine is prepared for several types of attachments, e.g. hammer, tiltrotator, grading bucket and clamshell bucket. In order to be able to connect these hydraulically to the machine, the pressure in the hydraulics must be released, see page 221.

The certification of each attachment and separate Operator's manual should be provided to the customers by the manufacturer of the attachment.

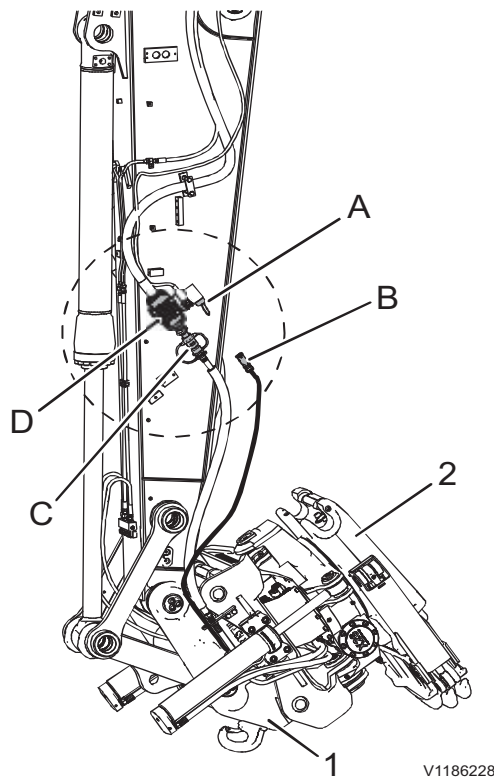

V1186228

- 1 Machine's quick coupler
- 2 Tiltrotator's quick coupler
- A Protection plug
- B Electrical connector tiltrotator
- C Hydraulic connectors
- D Stop valve for X1

Tiltrotator control system, description

Operating

The machine's quick coupler lock (1) can not be opened when the electrical connector on the tiltrotator is connected to the machine. This is a safety feature to ensure opening is not done by mistake when operating the tiltrotator.

Instead the quick coupler switch is used for attaching the attachment to the tiltrotator's quick coupler (2).

WARNING

Risk of crushing.

Hydraulic or mechanical failure could cause the attachments to fall, resulting in severe personal injury or death.

Always place the attachment on the ground when installing or removing it and make sure nobody enters the working area.

Installing the tiltrotator

- 1 Attach the tiltrotator to the machine's quick coupler (1) according to information about quick couplers in the quick coupler section on page 210.

NOTE!

Be careful so no hydraulic or electrical lines are damaged on the tiltrotator.

- 2 Place the tiltrotator on the ground and position the machine for best access to the hydraulic connectors.
- 3 **Stop the engine and depressurize the hydraulic system, see page 221.**
- 4 Connect the hydraulic lines on the tiltrotator to the connectors (C) on the machine. Start with the one on the right hand side (tank side).
- 5 Open the stop valves for X1 (D) with a wrench slowly. There is one stop valve on each side.
- 6 Open the protection plug (A) for the electrical connector on the dipper arm and place it next to the electrical connector.
- 7 Connect the electrical connector (B) on the tiltrotator to the dipper arm.
- 8 Install the attachment according to information about the quick coupler in the quick coupler section on page 210.

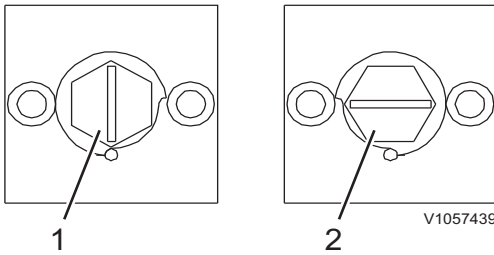

Stop valve for X1, positions

- 1 Open
- 2 Closed

NOTE!

Remember that the hydraulic system must be pressurized in order to make the quick coupler lock or unlock. Build up the pressure by carefully operating any of the features in the tiltrotator.

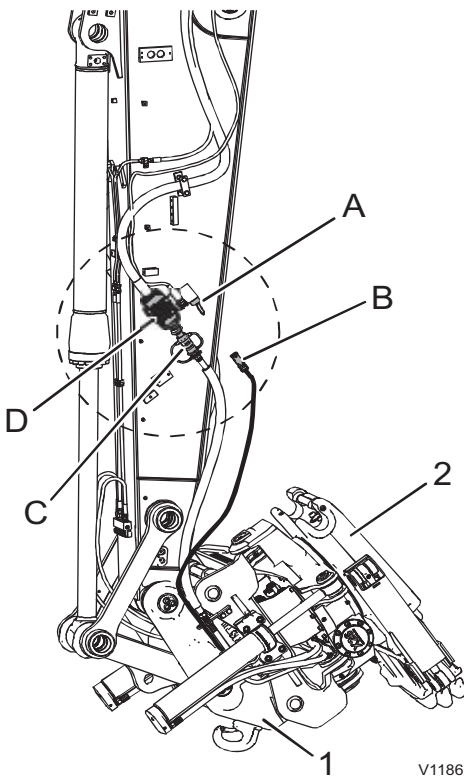

- 1 Machine's quick coupler
- 2 Tiltrotator's quick coupler
- A Protection plug
- B Electrical connector tiltrotator
- C Hydraulic connectors
- D Stop valve for X1

Removing the tiltrotator

- 1 Remove the attachment from the tiltrotator's quick coupler (2).
- 2 Put the tiltrotator flat on the ground.
- 3 **Stop the engine and depressurize the hydraulic system, see page 221.**
- 4 Close the stop valves for X1 (D) with a wrench slowly. There is one stop valve on each side.
- 5 Remove the electrical connector (B) and reinstall the protection plug (A) for the electrical connector on the dipper arm.
- 6 Remove the hydraulic lines from the hydraulic connectors (C) on the dipper arm.
- 7 Remove the tiltrotator from the machine's quick coupler (1) according to information about the quick coupler in the quick coupler section on page 210.

NOTE!

Be careful so no hydraulic or electrical lines are damaged on the tiltrotator.

210 Operating techniques
Attachments, connecting and disconnecting

Attachments, connecting and disconnecting

Attachment quick coupler

The machine can be equipped with a quick coupler between the dipper arm and attachment. With a hydraulic attachment quick coupler, changing attachments is carried out from the cab.

Different types of attachment quick couplers are available for your machine which are explained on the following pages.

WARNING

Risk of crushing.

Falling attachment could result in severe injury or death.

Make sure that the attachment, hydraulic hoses and connections are undamaged and securely fastened.

WARNING

Risk of crushing.

If the pressure in the attachment quick coupler cylinder drops, the attachment could fall off and cause serious crushing injury or death.

Never install shut-off valves in the lines leading to the cylinder for the attachment quick coupler.

Lifting hook

An optional lifting hook on the attachment quick coupler can be used for lifting operations. As the lifting hook is fitted on the attachment quick coupler, it can be used without an attachment. This improves visibility for the operator and increases the maximum permissible load.

NOTE!

Read the information in the Operator's Manual about lifting objects before using the lifting hook.

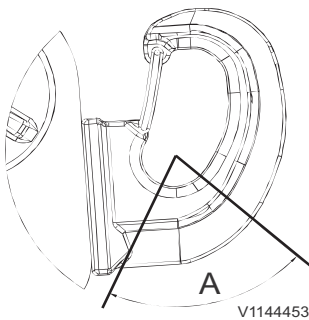

V1144453

Lifting hook

Do not lift outside of the hooks lifting area (A).

Attachment quick coupler

S60 / S70 attachment quick coupler (optional equipment)

S60 and S70 is operated hydraulically and consists of a flat mounting plate, which is attached to the end of the arm and the bucket link.

Buckets for S60 and S70 are equipped with two pins, which means that the bucket can be installed both for face shovel operation and backhoe excavation.

An additional feature is the front pin lock (FPL) which is a locking mechanism at the front of the S60 / S70 attachment quick coupler that hinders the tool to drop in case of incorrect locking of the rear pin.

Operating techniques

Attachments, connecting and disconnecting 211

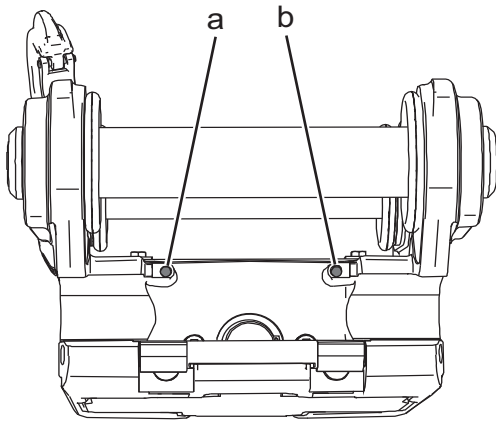

V1148418

S60 / S70 (with front pin lock)

a – Red indicator pin
b – Green indicator pin

Indicator pin S60 / S70

S60 / S70 (with front pin lock)

At the front on the attachment quick coupler there are two indicator pins. The following applies:

- Red indicator pin (a) fully extended = Front pin lock in unlocked position. Attachment quick coupler is open.
- Green indicator pin (b) fully extended = Front pin lock in locked position. Attachment quick coupler is closed.
- If both the red and green indicator pins are visible the attachment quick coupler is incorrectly locked to the rear pin. Start the connecting procedure from the beginning until the attachment quick coupler is closed.

Connecting attachment

WARNING

Risk of crushing!

Attachments that move unexpectedly can cause injuries.

Make sure people stay out of the working area when connecting or disconnecting attachments.

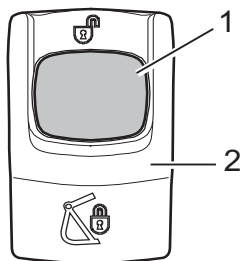

V1148410

2 - Attachment quick coupler switch (right instrument panel)

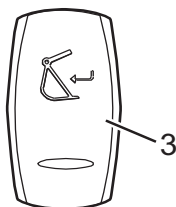

V1148413

3 - Attachment quick coupler confirmation switch (left instrument panel)

- 1 Initiate the opening of the attachment quick coupler as follows: Push the red button (1) of the attachment quick coupler switch (2) on the right instrument panel and push down the upper end of this switch simultaneously. The switch will be locked in this position.
A yellow quick coupler symbol and a check message for unlocked quick coupler will appear in the IC (Instrument Cluster). Additionally the buzzer sounds continuously.
- 2 Open the attachment quick coupler as follows: Press down and hold the upper end of the spring returned quick coupler confirmation switch (3) on the left instrument panel for 1 second.
A red quick coupler symbol and a warning message for unlocked quick coupler will appear in the IC (Instrument Cluster).
- 3 Check that the red indicator on the quick coupler is fully extended to indicate that the quick coupler is unlocked.

212 Operating techniques Attachments, connecting and disconnecting

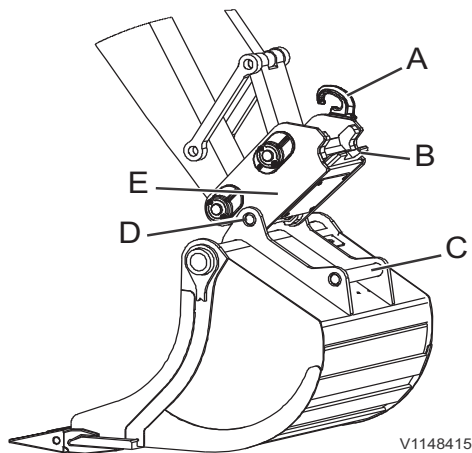

S60 / S70

- A Lifting hook
- B Lock wedge
- C Attachment rear pin
- D Attachment front pin
- E Attachment quick coupler

- 4 Operate the dipper arm so that the two hooks on the quick coupler engage the front pin of the attachment.
- 5 Move the quick coupler slowly towards the attachment until the quick coupler makes up correctly against the attachment.
- 6 Check that the quick coupler is correctly aligned against the tip of the attachment, adjust if necessary.
- 7 Press the lower end of the attachment quick coupler switch (2) to close the quick coupler.
A yellow quick coupler symbol and a check message for quick coupler locking confirmation will appear in the IC (Instrument Cluster) and the buzzer sound will continue.
- 8 Check that the red indicator pin is completely withdrawn and the green indicator is visible (depending on the attachment quick coupler version).
When the attachment is correctly locked in the attachment quick coupler, this has to be confirmed by pressing the upper end of the attachment quick coupler confirmation switch (3) for 1 second.
A yellow quick coupler symbol and a check message for quick coupler locking confirmation will disappear in the IC (Instrument Cluster) and the buzzer sound will stop.

WARNING

Risk of crushing.

If the red warning lamp for open attachment bracket lights up while working, the attachment could fall off and cause serious crushing injury or death.

Stop working with the machine immediately and make sure the attachment bracket is properly locked before starting to work again.

NOTE!

Even if the red indicator pin has been withdrawn and the green indicator is visible (depending on the attachment quick coupler version), the following tests must be carried out to check that the attachment is firmly fixed:

- Press the attachment against the ground. In this position move the bucket cylinder in and out to check that the lock wedge is in the correct position.
- If you are uncertain about whether the attachment is securely locked, exit the machine and check if the lock wedge is properly locked.

NOTE!

Do not use the machine, if the attachment quick coupler is not working.

Contact a qualified service technician if anything is wrong.

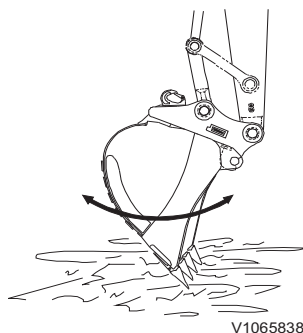

Disconnecting attachment

WARNING

Risk of crushing!

Attachments that move unexpectedly can cause injuries.

Make sure people stay out of the working area when connecting or disconnecting attachments.

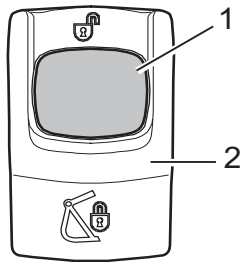

V1148410

2 - Attachment quick coupler switch (right instrument panel)

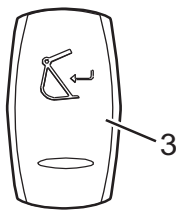

V1148413

3 - Attachment quick coupler confirmation switch (left instrument panel)

- 1 Place the machine on level and firm ground and lower the boom.
Curl the bucket fully towards the machine to protect the bucket from falling down during opening procedure.
- 2 Initiate the opening of the attachment quick coupler as follows: Push the red button (1) of the attachment quick coupler switch (2) on the right instrument panel and push down the upper end of this switch simultaneously. The switch will be locked in this position.
A yellow quick coupler symbol and a check message for unlocked quick coupler will appear in the IC (Instrument Cluster). Additionally the buzzer sounds continuously.
- 3 Open the attachment quick coupler as follows: Press down and hold the upper end of the spring returned quick coupler confirmation switch (3) on the left instrument panel for 1 second.
A red quick coupler symbol and a warning message for unlocked quick coupler will appear in the IC (Instrument Cluster).
Curl the bucket fully in to open the quick coupler. If necessary, the release pressure can be increased by driving the bucket cylinder to its end position.
- 4 When the red indicator pin on the quick coupler extends fully and the green indicator is completely withdrawn (depending on the attachment quick coupler version), release the attachment from the quick coupler by carefully moving the bucket cylinder to its inner position (bucket out).
If the red indicator pin not extends fully and the green indicator is not completely withdrawn (depending on the attachment quick coupler version), increase the hydraulic pressure to the locking cylinder by carefully moving the bucket cylinder to its outer end position (bucket in).

214 Operating techniques Attachments, connecting and disconnecting

Attachment quick coupler

Applies to models: EW160E

S6 attachment quick coupler (optional equipment)

The S6 is operated hydraulically and consists of a flat mounting plate, which is attached to the end of the arm and the bucket link. Buckets for S6 are equipped with two pins, which means that the bucket can be installed both for face shovel operation and backhoe excavation.

A hydraulic cylinder on the attachment quick coupler actuates the lock wedges on the bracket. Hydraulic pressure from the servo circuit keeps the bucket locked. This means that the lock wedges adjust themselves and continuously eliminate any play.

The attachment bracket (quickfit) is opened with hydraulic pressure from the working hydraulics circuit.

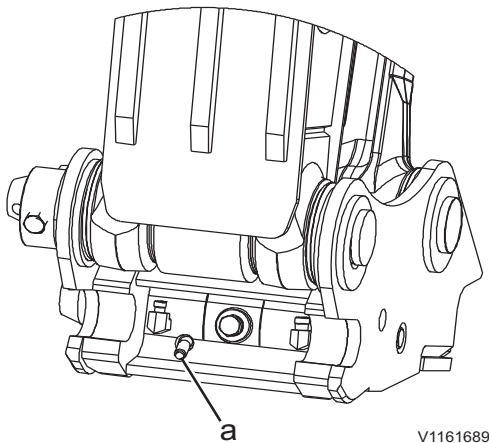

V1161689

S6 attachment quick coupler
a - indicator pin

Lifting hook

An optional lifting hook on the attachment quick coupler can be used for lifting operations, see page 210 "Lifting hook" for a detailed description of the lifting hook.

Indicator pin

At the front on the attachment quick coupler there is an indicator pin.

- Indicator pin (a) not visible: S6 attachment quick coupler closed.
- Indicator pin (a) visible: S6 attachment quick coupler open.

Connecting and disconnecting attachment

For connecting and disconnecting attachment on S6 attachment quick coupler, see description for S60 attachment quick coupler "Connecting attachment" and "Disconnecting attachment".

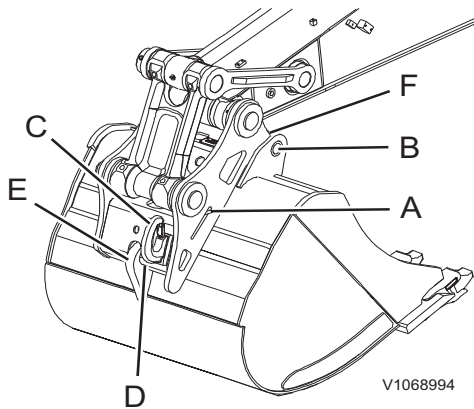

S1 attachment quick coupler

- A Red indicator pin
- B Bucket shafts
- C Lifting hook (optional)
- D Locking wedge
- E Bucket rear hook
- F Hooks for gripping attachment

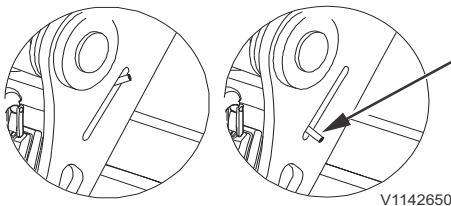

Indicator pin on S1

Attachment quick coupler

S1 attachment quick coupler (optional equipment)

The S1 attachment quick coupler consists of flat mounting plates assembly which are attached to the end of dipper arm and bucket link. There are two hooks (F) on the plate for the pins (B) on the bucket.

An optional lifting hook (C) on the attachment quick coupler can be used for lifting operations, see page 210 "Lifting hook" for a detailed description of the lifting hook.

The attachment quick coupler is equipped with a double-acting hydraulic cylinder. The locking wedge (D) is fitted to its piston rod. Servo pressure acts on the piston of the locking cylinder, locking the bucket in place against rear hook (E). This means that the locking wedge adjusts itself and provides gap-free locking.

When the servo pressure is transferred to the piston rod side, the locking wedge (D) is released. If necessary, the release pressure can be increased by driving the bucket cylinder in its end position.

Indicator pin

There is an indicator pin on the left side of the attachment quick coupler.

- Indicator pin not visible: Attachment quick coupler is closed.
- Indicator pin visible: Attachment quick coupler is open.

Connecting and disconnecting attachment

For connecting and disconnecting attachment on S1 attachment quick coupler, see description for S60 / S70 attachment bracket "Connecting attachment" and "Disconnecting attachment" on page 210.

216 Operating techniques Attachments, connecting and disconnecting

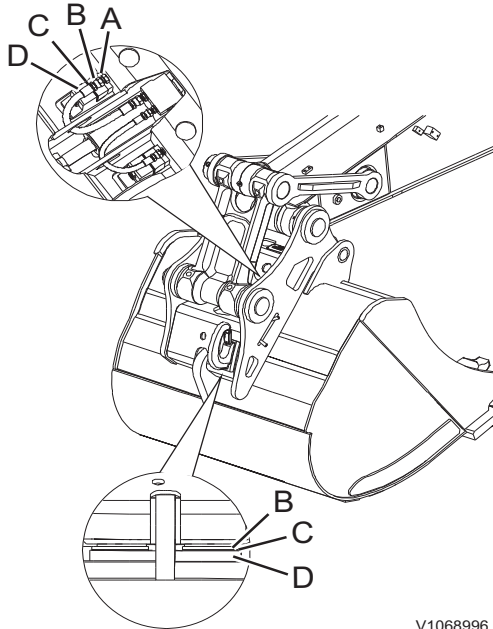

V1068996

S1 (new version)

- A Attachment bracket (quickfit)
- B Spacer
- C Shim
- D Screw holder

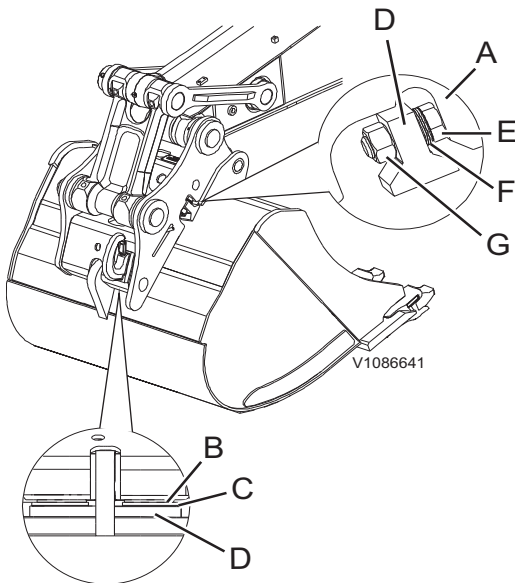

V1086641

S1 (former version)

- A Attachment bracket (quickfit)
- B Spacer
- C Shim
- D Screw holder
- E Screw
- F Washer + shim
- G Nut

S1 attachment bracket (quickfit) , adjusting

Adjusting — New version of the S1

! WARNING

Risk of crushing!

Attachments that move unexpectedly can cause injuries.

Make sure people stay out of the working area when connecting or disconnecting attachments.

- 1 Disconnect the attachment.
- 2 Remove any shims between the screw holder (D) and the spacer (B).
- 3 Hook on and lock the attachment.
- 4 Check whether spacers and attachment bracket are fitted correctly (4 places).
- 5 Check the gap between the spacers and attachment bracket. The attachment bracket should be completely matched against the spacers.
- 6 If there exists a gap between them, adjust it with shims as follows:

■ Disconnect the attachment.

■ Fit the requisite number of shims between screw holder and spacer.
If necessary, use both thicker shim and thinner shim.

■ Connect the attachment.

■ Check the gap again, if there still is a gap repeat the same procedure.

Adjusting — Former version of the S1

! WARNING

Risk of crushing!

Attachments that move unexpectedly can cause injuries.

Make sure people stay out of the working area when connecting or disconnecting attachments.

- 1 Disconnect the attachment.
- 2 Remove any shims between the screw holder (D) and the screw (E), between the screw holder (D) and the spacer (B).
- 3 Hook on and lock the attachment.
- 4 Check whether spacers and attachment bracket are fitted correctly (4 places).
- 5 Check the gap between the spacers and attachment bracket. The attachment bracket should be completely matched against the spacers.
- 6 If there exists a gap between them, adjust it with shims as follows:

■ Disconnect the attachment.

■ Fit the requisite number of shims between screw holder and spacer.

If necessary, use both thicker shim and thinner shim.

Operating techniques

Attachments, connecting and disconnecting 217

- Connect the attachment.
- Check the gap again, if there still is a gap repeat the same procedure.

Attachment quick coupler

Universal attachment quick coupler (optional equipment)

The universal attachment quick coupler is equipped with a double-acting hydraulic cylinder.

The hook for gripping the attachment is fitted to its piston rod. Working pressure acts on the piston on the lock cylinder, locking the attachment in place against the rear bucket pin. This means that the hook adjusts itself and provides gap-free locking.

Another feature of the universal attachment quick coupler is the front pin lock (FPL).

Front pin lock (FPL) is a locking mechanism at the front of the universal attachment quick coupler which hinders the tool to drop in case of incorrect locking of the rear pin.

Lifting eye

With the aid of the lifting eye, the machine can be used for lifting operations. As the lifting eye is positioned on the attachment quick coupler, it can be used without a bucket. This improves visibility for the operator and increases the maximum permissible load.

Connecting attachment — universal attachment quick coupler

⚠ WARNING

Risk of crushing!
Attachments that move unexpectedly can cause injuries.
Make sure people stay out of the working area when connecting or disconnecting attachments.

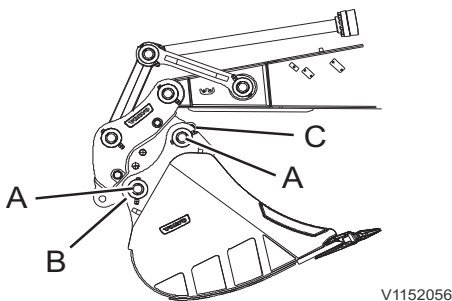

- A. Bucket pins
- B. Locking hook
- C. Front pin lock (FPL)

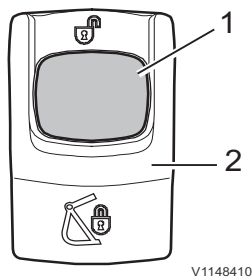

- 2. Attachment quick coupler switch (right instrument panel)

- 1 Position the machine on firm level ground.
- 2 Place the attachment quick coupler above the bucket. Make sure the locking hook (B) is fully retracted before connecting. To fully retract the locking hook curl in the bucket completely towards the machine.
- 3 Initiate the opening of the empty attachment quick coupler as follows:
Push the red button (1) of the attachment quick coupler switch (2) on the right instrument panel and push down the upper end of this switch simultaneously. The switch will be locked in this position.
A yellow quick coupler symbol and a check message for unlocked quick coupler will appear in the IC (Instrument Cluster). Additionally the buzzer sounds continuously.

218 Operating techniques Attachments, connecting and disconnecting

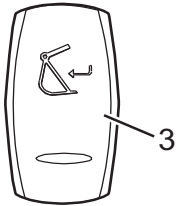

V1148413

3. Attachment quick coupler confirmation switch (left instrument panel)

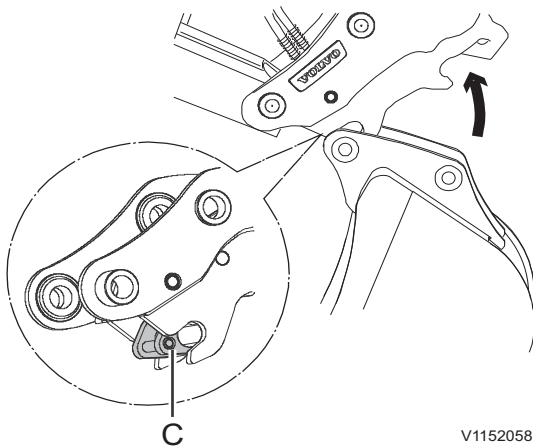

V1152058

C - Front pin lock (FPL)

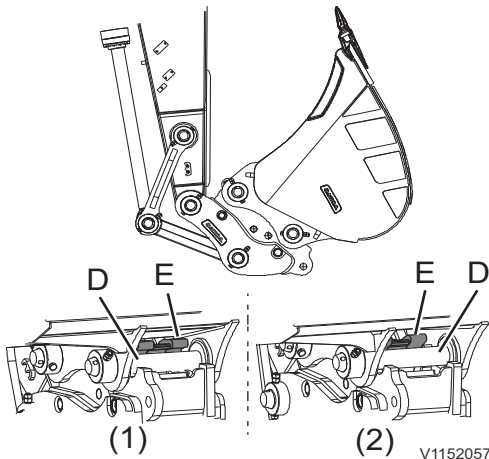

V1152057

D. Bucket pin

E. Locking hook

(1) Locking hook fully extended, locked position

(2) Locking hook fully retracted, unlocked position

- 4 Open the attachment quick coupler as follows:
Press down and hold the upper end of the spring returned quick coupler confirmation switch (3) on the left instrument panel for 1 second.
A red quick coupler symbol and a warning message for unlocked quick coupler will appear in the IC (Instrument Cluster).
- 5 Ensure that the rear locking hook (B) is unlocked before hooking onto the bucket pin. Otherwise the bucket pin could not be engaged properly.
- 6 Curl the attachment quick coupler and hook it onto the bucket pin.
- 7 Slowly curl in the attachment quick coupler towards the bucket.
- 8 Press the lower end of the attachment quick coupler switch (2) to close the quick coupler.
A yellow quick coupler symbol and a check message for quick coupler locking confirmation will appear in the IC (Instrument Cluster) and the buzzer sound will continue.

NOTE!

Visually check that the front pin lock is fully engaged.

- 9 Lift and curl in the bucket fully towards the dipper arm and hold it there for approximately 5 seconds to ensure the attachment quick coupler has fully locked on to the bucket.
A visual indicator that the bucket is locked in the universal quick coupler is the position of the locking hook (E) on the bucket pin (D), see illustration.
- 10 When the attachment is correctly locked in the attachment quick coupler, this has to be confirmed by pressing the upper end of the attachment quick coupler confirmation switch (3) for 1 second.
A yellow quick coupler symbol and a check message for quick coupler locking confirmation will disappear in the IC (Instrument Cluster) and the buzzer sound will stop.
- 11 Test if the attachment quick coupler is securely fastened with the following procedure:

Operating techniques

Attachments, connecting and disconnecting 219

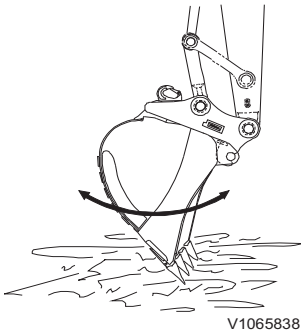

- Press the bucket against the ground. In this position, curl the bucket in and out to check that it is locked in the correct position.
- If you are unsure whether the bucket is securely locked to the attachment quick coupler, get out and check if the locking hook (B) is correctly locked. The initial locking of the bucket to the coupler is done by the rear locking hook (B). Also the front pin lock (A) should be fully engaged as this is an additional device to increase the safety.

WARNING

Risk of crushing.

If the red warning lamp for open attachment bracket lights up while working, the attachment could fall off and cause serious crushing injury or death.

Stop working with the machine immediately and make sure the attachment bracket is properly locked before starting to work again.

NOTE!

Do not use the machine if the attachment quick coupler is not working.

Contact a qualified service technician if anything is wrong.

Disconnecting — universal attachment quick coupler

WARNING

Risk of crushing!

Attachments that move unexpectedly can cause injuries.

Make sure people stay out of the working area when connecting or disconnecting attachments.

- 1 Position the machine firm level ground with the bucket resting on the ground.
- 2 Curl in the bucket completely towards the dipper arm (to release the locking mechanism).
- 3 Initiate the opening of the attachment quick coupler as follows: Push the red button (1) of the attachment quick coupler switch (2) on the right instrument panel and push down the upper end of this switch simultaneously. The switch will be locked in this position.

A yellow quick coupler symbol and a check message for unlocked quick coupler will appear in the IC (Instrument Cluster). Additionally the buzzer sounds continuously.

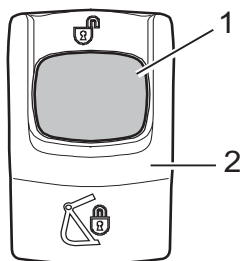

2. Attachment quick coupler switch (right instrument panel)

220 Operating techniques Attachments, connecting and disconnecting

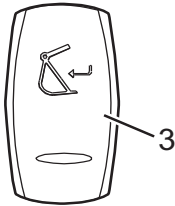

V1148413

3. Attachment quick coupler confirmation switch
(left instrument panel)

- 4 Open the attachment quick coupler as follows:
Press down and hold the upper end of the spring returned quick coupler confirmation switch (3) on the left instrument panel for 1 second.
A red quick coupler symbol and a warning message for unlocked quick coupler will appear in the IC (Instrument Cluster).
Curl the bucket fully in to open the quick coupler. If necessary, the release pressure can be increased by driving the bucket cylinder to its end position.
- 5 Ensure the front pin lock (C) is unlocked to hook off from the bucket pin. Otherwise the bucket pin can not be disengaged properly.
- 6 Lower the bucket and curl out to lift up the attachment quick coupler from the bucket.
- 7 Place the bucket flat on the ground and unhook it.

Maintenance — universal attachment quick coupler

Besides the greasing (see page 278), the universal attachment quick coupler has also another maintenance interval which is the adjustment of the set screw every 500 hours, see page 298.



Pressure release

Hydraulic system, releasing pressure

WARNING

Risk of high pressure injection.

Residual pressure in the hydraulic system could lead to oil under high pressure jetting out and cause serious injury, even if the engine has not been running for some time.

Always release the pressure before any kind of service of the hydraulic system is carried out.

- 1 Start the engine in order to build up servo pressure and charging the pressure accumulator.
- 2 Place the machine in a suitable service position, see page 247.
- 3 After engine is shut down, turn ignition key to running position (Do not start engine).
- 4 Move the control lockout lever up to unlock the system.
- 5 Move the operating levers forwards/rearwards/left/right to their respective end positions a couple of times.
- 6 Release the pressure in the tank by pressing the knob on the ventilation filter.

Buckets

Working with buckets

The bucket is manoeuvred with the left and right control levers, see page 94. For information about the Volvo tooth system, see page 314.

- Before beginning to dig, apply the digging brake, see page 163.
- Work with the superstructure longitudinal to the undercarriage. The machine capacity is then utilised most efficiently.
- Lower stabiliser legs/stabiliser blade for best stability.

Float position

Float position means that the piston rod sides of the boom cylinders are connected to the hydraulic tank when the function is activated.

The boom can float freely and it is only the weight of the digging equipment and the load that lowers the boom when the control lever is moved forwards.

Use the float position when the attachment is to follow uneven ground, for example when clearing rocks, clamshell handling and when unloading barges and truck platforms. The float position also provides a smoother action when emptying.



V1186171

Float position symbol

Float position activation

- When the boom float position switch on the right control lever, see page 94, has been pushed the float position symbol appears in the IC (Instrument Cluster). Now the float position function is preselected but not active.
- When the control lever is being actuated to lower the boom the float position becomes active. The boom can then move freely upwards or downwards depending on the ground conditions, when the control lever is being held in the forward position.
- As long as the float position is active the cylinder piston rod sides are connected to the tank even if the control lever is in the neutral position.
This can be an advantage for e.g. working with a hydraulic hammer (hydraulic breaker).

Power Boost

Power Boost is used when additional power is required, e.g. when lifting heavy objects. When Power Boost is engaged, a higher hydraulic pressure is obtained and thereby greater digging forces. However, the digging movements will be somewhat slower.

Power Boost remains engaged for approx. 10 seconds by default, this time can be adjusted.

- Activate Power Boost with a button on the right control lever, see page 94. A control lamp on the display unit lights up.



V1186172

Power boost symbol

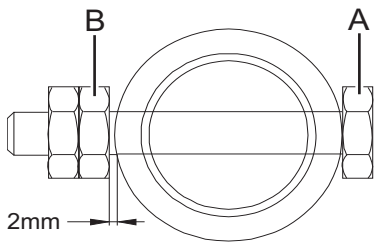

V1065823

A Lock bolt
B Nut

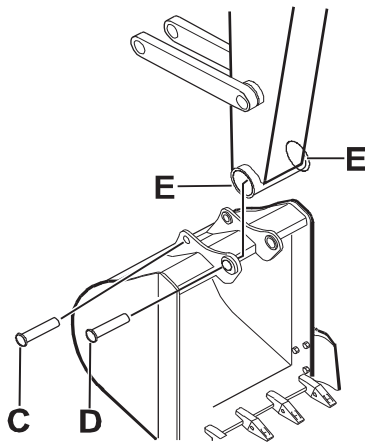

V1086072

C Pin
D Pin
E O-ring

Changing bucket

Remove bucket

WARNING

Risk of splinter injury.
Striking the bucket pin with a hammer could cause metal chips to fly around and cause serious splinter injury.

Always wear face and eye protection, hard hat and gloves while removing and installing the bucket pins.

- 1 Lower the bucket lightly on the ground.
- 2 Remove nuts (B) and then lock bolt (A) of each pin.
- 3 Remove pins (C and D) and O-rings (E), then remove the bucket.

NOTICE

Block the removed bucket to stabilise it. Keep the pins clean and do not damage the O-ring.

Install bucket

CAUTION

Risk of cutting and crushing.
Loose parts could cause crushing and cutting injury.
Never use your fingers for checking alignment between loose parts. Always use a tool.

- 1 Align the arm to bucket hole and link hole.
- 2 Apply grease to the hole.
- 3 Put O-ring (E) at the arm position
- 4 Insert pins (C and D).
- 5 Install lock bolt (A) and nuts (B) of each pin.

NOTICE

Make sure that there is a clearance of at least 2 mm (0.08 in) between nut and pin boss. Lubricate the pin.

Grab bucket

(Clamshell bucket)

A grab bucket (also called clamshell bucket) is an optional equipment.

The grab bucket can be connected to X1 or the X3 hydraulic line, depending on the specifications of the attachment.

If the machine is equipped with bucket cylinder grapple lines, see page 225 for details.

Operating a grab bucket

- Close (A) and open (B) the grab bucket with the right control lever (R).
- **Grab bucket on X1:** Rotate the bucket counter-clockwise with the button or roller switch (C) and clockwise with (D) on the right control lever (R).
- **Grab bucket on X3:** Rotate the bucket counter-clockwise with the button or roller switch (C) and clockwise with (D) on the left control lever (L).

224 Operating techniques
Buckets

For operating a grab bucket in combination with a tiltrotator see page 102.

NOTE!

Bear in mind that the rotation of the bucket may vary depending on how the hydraulic hoses are connected.

	<p>Grab bucket on X1 R - Right control lever A Close bucket (R) B Open bucket (R) C Rotate counter-clockwise (R) D Rotate clockwise (R)</p>
	<p>Grab bucket on X3 L - Left control lever / R - Right control lever A Close bucket (R) B Open bucket (R) C Rotate counter-clockwise (L) D Rotate clockwise (L)</p>

Pivot axle locking is recommended, see page 80. Unnecessarily great swinging of the bucket may cause material to fall out and make the bucket difficult to control.

NOTICE

A grab bucket (clamshell bucket) without oscillation brake should not be disconnected when in a standing position, as the attaching plate will then lie on one side or the other. This may cause injuries and make it more difficult to re-attach to the machine.

NOTE!

Release the pressure from the hydraulic system before attaching or disconnecting a grab bucket, see page 221.

Attaching grab bucket

- 1 Move the attachment quick coupler on the machine into line with the grab bucket attaching plate and lock the parts together (make sure that no hoses become pinched).
- 2 Connect the hydraulic hoses.

Disconnecting grab bucket

NOTE!

When the bucket is standing on the ground, the rubber stop on the attaching plate should be placed against the grab bucket before the attachment quick coupler is disconnected.

- 1 Place the grab bucket firmly on the ground with the jaws apart, or lay the bucket on its side on the ground.
- 2 Disconnect the hydraulic hoses from the bucket.

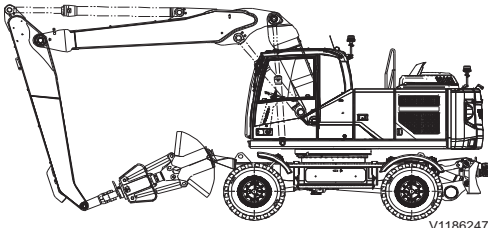

Travelling on public roads

3 Disconnect the attachment.

NOTE!

When travelling on public roads with a two-piece boom and grab bucket, the bucket must be suspended as shown in the figure.

NOTE!

For certain attachment combinations there is risk that the attachment may strike the cab. Take care when working close to the machine.

Bucket cylinder grapple lines

This instruction is valid for connecting a grab bucket (also called clamshell bucket) on the optional bucket cylinder grapple lines. The grab bucket is then controlled with the right control lever bucket function, see page 94.

Depending on if bucket or grab bucket is used select the correct position by turning the valves with the supplied lever as shown in the picture.

Release the pressure from the hydraulic system before changing the valve position, see page 221.

Turn the two valves completely in the required position for the bucket (A) or the grab bucket (B). Both valves must click in the required position to lock it.

NOTE!

If the above stated conditions are not respected, the inner sealing of the valve could get damaged. That would finally lead to a creeping of the bucket cylinder during operation.

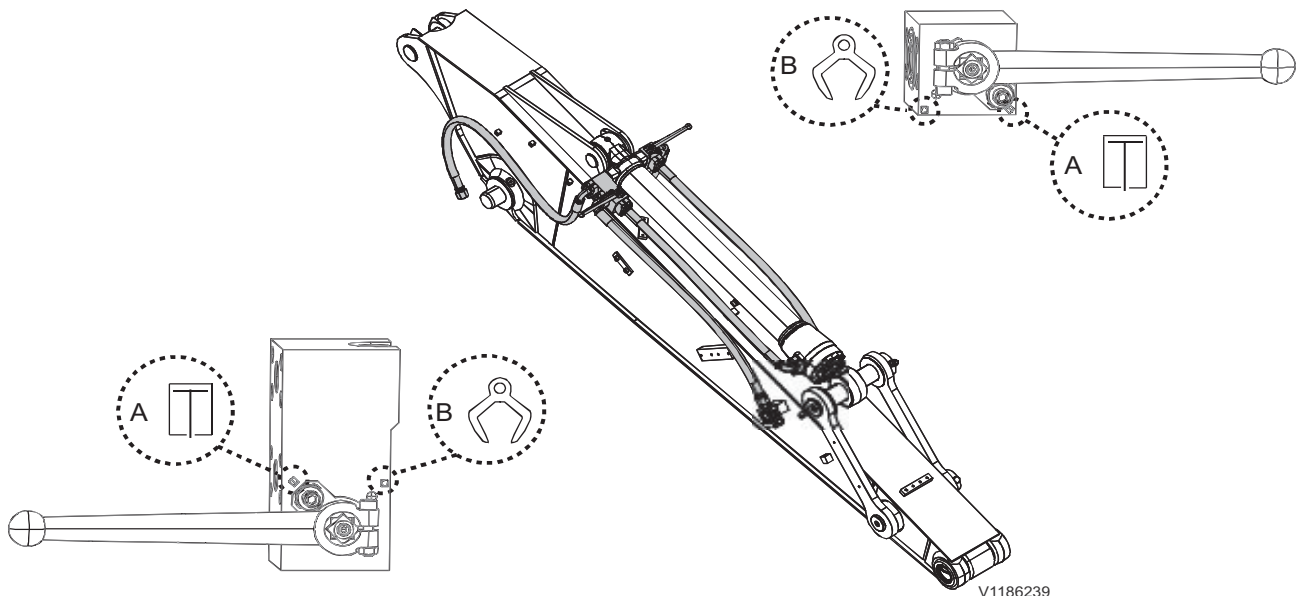

- A Bucket position
- B Grab bucket position

**NOTE!**

Due to minimal internal leakage of the cylinder, the piston rod of the bucket cylinder might creep out during operating the grab bucket.

This is a normal behavior of the machine.

To move the cylinder in again, it is not necessary to switch over the shut off valves.

This functionality is already integrated in the shut off valves, merely the function "bucket out" has to be actuated.

Move the control lever in direction "bucket out" until the piston rod is moved in completely, see page 94.

Offset boom

Mono-block offset boom

(Optional equipment)

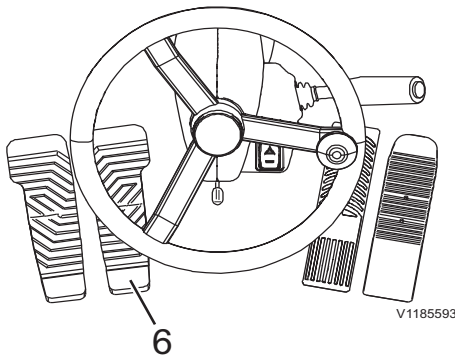

WARNING

Risk of tipping over.

Excavating with a fully angled offset boom affects the balance of the machine and could cause the machine to tip over.

Always lower the stabiliser legs and operate with greatest care when excavating with the boom in the offset position.

The end of the boom can be angled sideways to the left and to the right.

The angle on the boom is controlled with optional equipment pedal (6).

Pedal forward = left

Pedal rearward = right

Two-piece offset boom

(optional equipment)

WARNING

Risk of tipping over.

Excavating with a fully angled offset boom affects the balance of the machine and could cause the machine to tip over.

Always lower the stabiliser legs and operate with greatest care when excavating with the boom in the offset position.

The two-piece offset boom has one more joint, allowing the boom to be angled at one further point.

The two-piece offset boom is activated with a button on the left control lever, see page 94. Keep this button pressed down and operate the offset boom with optional equipment pedal (6).

If the button is not pressed down, the pedal will operate the two-piece boom.

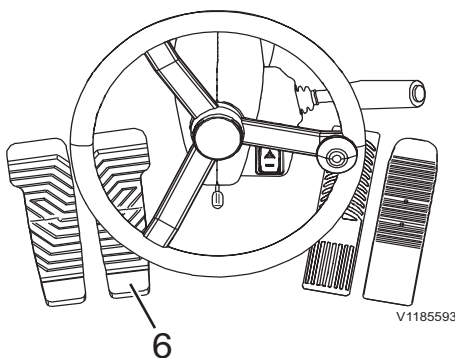

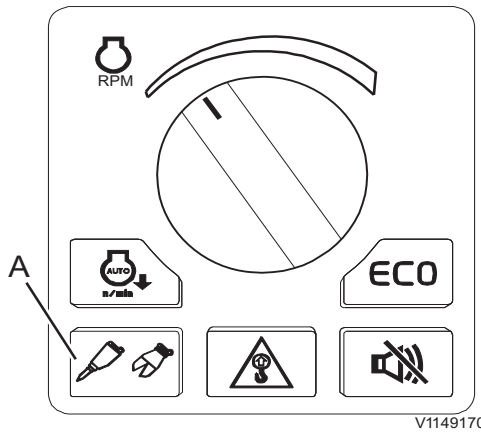

Hammer/shear button on keypad

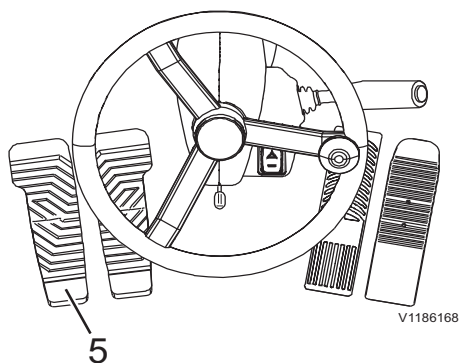

Hammer

Hammer/shear

For complete instructions for the hammer, read the separate Operator's Manual for the hammer.

NOTE!

Please note when the grapple bucket change over function is activated, X1 always works double-acting and with maximum volume flow, independent of the X1 tool setting. The X1 pressure setting is still active.

! WARNING

Risk of severe personal injury.

While working with the hammer flying chips of rock could cause severe injury.

Provide protective nets for the windscreens. Keep windows and door closed and prevent persons from entering the risk zone when operating the hydraulic breaker.

Protective net for the windscreens is available as an option, contact your local dealer.

Working with hammer

- Select the X1 tool with the button (A) on the keypad.
- Operate the hammer/shear with the buttons or roller switch on the right control lever or with the pedal for optional equipment (5).

Bear the following in mind when working with a hammer:

- Do not operate the hydraulic cylinders closer to their end positions than 10 cm (4 in).
- If the machine is provided with an attachment quick coupler, this must be checked every day at the same time as rectifying any play.
- Lubricate the excavator unit bearings twice a day.
- When a new machine is delivered, pipe clamps on the excavator unit should be check-tightened. (Repeat at intervals of a couple of days until the clamps remain "tight".)
- Remove stone chips and other objects that have found their way into the machine. These can easily get stuck and cause damage by chafing on for example the hydraulic hoses.

NOTICE

Never move the machine when the hammer bar is applied. Never use the hammer as a support when loading on a trailer. The hammer may be damaged.

- The best working area is in the longitudinal direction of the undercarriage and within an approximate 45° sector in both directions.
- Avoid sideways forces on the hammer as these increase the wear on the hammer bushings. This thereby reduces the risk of the bar slipping. Bear in mind that the hammer is not a tool for breaking or prizing, but a striking tool.

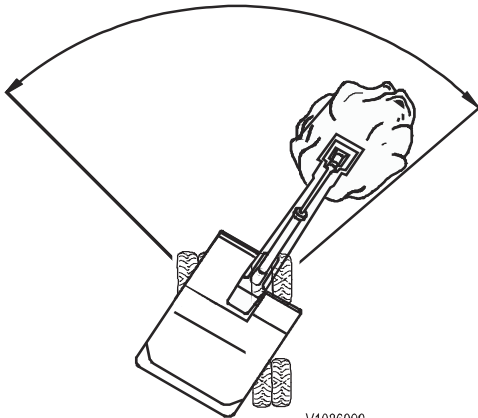

V1086090

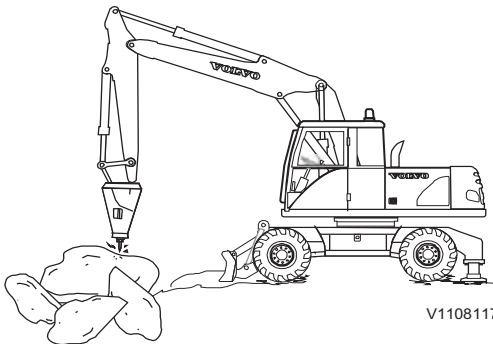

V1108117

- If there is no special automation for making an initial mark, this can be facilitated like this: Make a short series of strokes with a light feeding force, so that a chipped-out indentation like a punch mark is made.
- Adapt the load on the hammer during the stroke sequence in order to keep the vibrations in the machine to a minimum while at the same time the hammer is working most efficiently. On larger machines, the float position, may, however, provide a suitable load on the hammer.
- Do not transfer so much load onto the hammer that the front end of the machine begins to be raised off the ground.
- If the block has not cracked after a series of approx. ten strokes, change the point of attack.
- It is easier to load the hammer correctly, when the arm is held close to the vertical line. The arm and bucket cylinders are then also far from their end positions, which is preferable.
- Avoid working with the hammer horizontally as this will cause great wear.
- When the material breaks, "catch hold of" the hammer, before the block breaks up completely. Switch off the hammer immediately to avoid idle strokes, otherwise the locking of the hammer bar may be damaged, at the same time as the strain on the excavator equipment increases.

If the hammer does not work, check the following:

- 1 Are the hydraulic oil hoses, supplying the hammer with oil, blocked? Check that any quick-action couplings are properly pressed in and that shut-off valves are fully open.
- 2 Do the hoses vibrate strongly? Check that the pressure in the pressure accumulator is correct.

If the hammer still does not function correctly in spite of the above mentioned measures, get in touch with the supplier of the hammer.

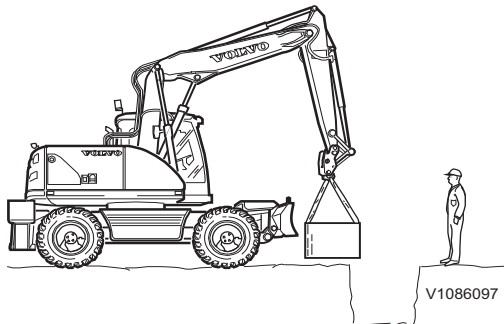

Lifting objects

NOTICE

In certain countries there are local regulations for when the machine is used for lifting purposes, for example when lifting a freely suspended load. Contact an authorised dealer for further information.

NOTICE

Make sure that the piston rods of the hydraulic cylinders are not in their end position when lifting. The piston rods or attaching points may otherwise be damaged.

Safe lifting make great demands on the operator, therefore read the below recommended steps before starting any lifting.

- Use qualified and properly trained operators who have:
 - Specific machine knowledge and training.
 - Read and understood the operator's manual and its load charts, see page 373.
 - Specific machine knowledge and training how to properly rig the load.
 - Full responsibility for all aspects of the lift.
- Interrupt the lift if not fully confident of a safe lift.
- Select machine with sufficient capacity for the total expected load, reach and swing. Ideally, load should be less than the load listed on the load chart at maximum reach across the undercarriage, see page 373.
 - Know the mass (weight) of the item to be lifted.
 - Know the start and finish positions, load lifting position and setting position.
 - Know the machine configuration, especially the dipper arm and boom lengths and counterweight mass.
 - Choose the correct lifting chart taking into account all attachments and rigging materials that will be used during the lift. The weight of the rigging materials and attachments, should be deducted from the load capacity.
- Warm up the machine to normal working temperatures.
- Position the machine on firm level ground.
- Properly set outriggers and blade when applicable.
- Visually inspect the rigging materials for defects, cracks, or any other damage before lifting objects.
- Once the load is properly rigged, ensure all ground workers are clear of the load and the machine. If guiding of the load is necessary, use ropes or other type of slings tied to the load to keep ground workers at a safe distance.
- Use a trained signaller to direct all aspects of the move.
- Do not use the swing or arm-in operation to drag a load.

Stability

The stability of working machines is highly changeable and exposed to great variations.

In order to carry out the work safely, the operator must himself or herself think about and take into consideration the particular conditions that apply at a specific moment.

- A condition for good stability is that the machine is standing on level, firm and safe ground.
- Lift with the excavator unit over the rear axle. The machine capacity is then utilised most efficiently.

- Be ware of soft, uneven or sloping ground and of landslips, sideways loads and other similar risks. If the machine is standing on sloping ground, the centre of gravity is displaced and, when lifting, the machine may take up a position where it will be close to tipping over.
- Make sure that the ground is firm and safe. Unstable ground, for example loose sand or soft earth, may make the work unsafe, if loads, close to the maximum values in the loading table (page 373), are taken.
- Do not make fast slewing movements with a suspended load. Bear the centrifugal force in mind.

Slinging long loads

- Boards, planks, reinforcing irons or similar should have the sling arranged so that they cannot fall out.
- When lifting girders, a pair of girder scissors should preferably be used.
- Place for example cut-up air hoses between the sling and sharp edges.
- The sling should be well tightened.

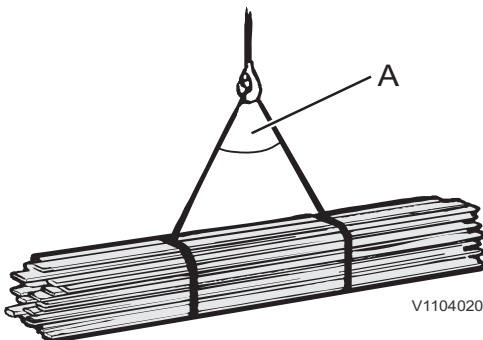
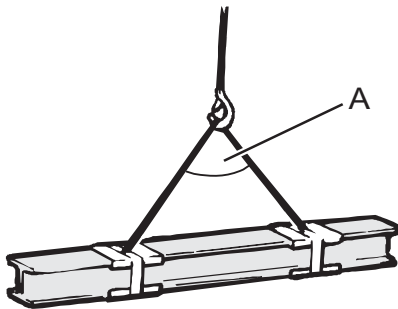
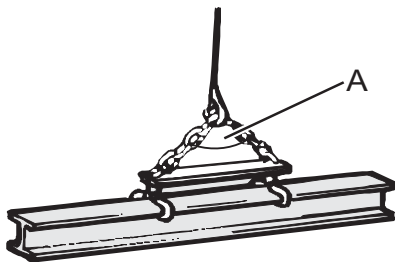

A - Maximum 120°

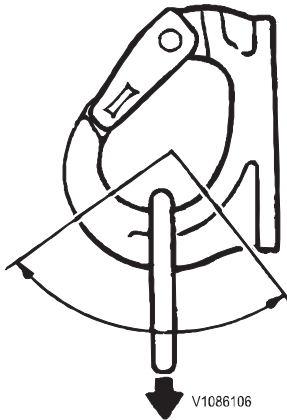

Permissible working range of lifting hook

Lifting hook

! WARNING

Risk of crushing.

A lifting hook loaded outside the permissible working range could cause the load to fall off and lead to serious crushing injury or death.

Never load the lifting hook outside the permissible working range.

There is an optional lifting hook on the attachment quick coupler. It must not be exposed to lateral loads. The load must be applied in the longitudinal direction of the hook. While operating, check that the load at all times lies within the permissible lifting area of the hook.

NOTE!

Only use lifting device recommended by Volvo in order to avoid damage to the machine. Contact an authorised dealer for information regarding other lifting device.

NOTE!

When lifting, the pivot axle locking must be engaged, see page 80.

NOTE!

Bear in mind that the lifting capacity of the machine is greater when the attachment is pulled in closer to the machine. The lifting hook is made for lifting a maximum of 5000 kg (11000 lb).

Lifting equipment and lifting hook must be clean and in a serviceable condition. Before lifting, check that the lifting device is correctly secured.

! WARNING

Risk of fatal accidents.

A suspended load could drop if the hydraulic system fails and cause fatal accidents and serious injury or death.

Never leave the machine with a suspended load.

Lifting device on connecting rod (optional equipment)

Lifting device (2) on connecting rod (1) is designed to lift the marked permissible load on the lifting device. Consider also the lifting capacity of your machine, see page 373.

Transporting load

! WARNING

Risk of serious accidents.

A moving load could cause serious injury if it hits persons.

Always watch the load while operating.

NOTICE

The overload warning must always be engaged when lifting a suspended load.

NOTE!

Use an assistant when required.

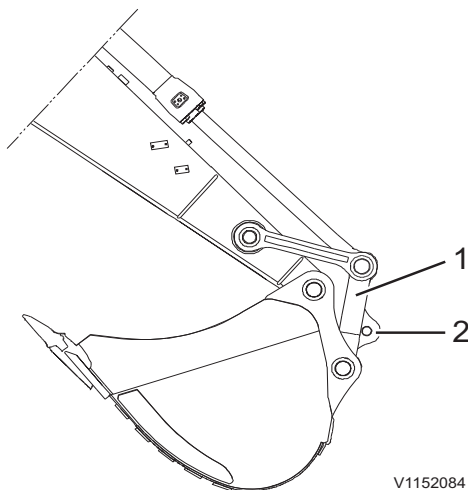

- 1 Connecting rod
- 2 Lifting device on connecting rod



- Always check that the load is safely suspended.
- If the visibility is limited by the load, great care must be exercised. When required, ask an assistant to guide you past critical areas. Do not lift the load until the assistant has reached a safe position, but is still fully visible.
- Always keep your eyes on the bucket or the load while it is moving. Stop the machine instead of taking your eyes off the load.
- Only use approved and undamaged lifting straps, chains and other lifting equipment. They must meet applicable national regulations for lifting devices. Make sure that the maximum load is stated and not exceeded.
- Volvo disclaim all responsibility for all lifting equipment.
- Never overload the machine. Permissible load is stated in the specification chapter, see page 373.
- Put the travelling speed control in creep speed, see page 80.

NOTE!

The limit for permissible load may be exceeded if reach or boom angle are altered.

- Lift the load using an approved and functioning safety hook.
- If needed, when lifting heavy loads, the power boost function may be activated to achieve more lifting power, see page 94.
- Avoid jerks, lift slowly.
- Never leave the machine with a suspended bucket or load.
- The undercarriage should be aligned with the superstructure in order to achieve best stability.

NOTE!

The pivot axle locking must be engaged, see page 80.

Overload warning

NOTICE

The overload warning does not give the actual machine limit, but constitutes an indication of a potential risk of tipping over in case of deteriorating stability.

The overload warning is engaged and disengaged with the button on the machine control keypad, see page 80.

NOTICE

The overload warning must always be engaged when lifting a suspended load.

When an overload is registered, the central warning lamp and the control lamp are alight on the IC (Instrument Cluster) and the buzzer sounds. When digging, the overload warning should be disengaged.

Overload warning system, checking

NOTE!

A check of the overload warning equipment must be carried out every 1000 hours, see page 300.



Equipment towing

Trailer towing solution (TTS)

(optional)

The trailer towing option is intended to be used for short transports of work side equipment with a trailer on the excavator. The trailer hitch for towing is attached either on the blade or on the outrigger (depending on option) and can be installed if needed and removed for normal machine operation.

This section about trailer towing contains rules that must be followed in order to operate the machine safely with a trailer. However, these rules are to be followed in conjunction with laws or other national regulations applicable in the area where the machine is operated.

CAUTION

Risk of crushing.

An open jaw of a trailer hitch could close unexpectedly and crush your fingers.

For all work on the trailer hitch the jaw must be closed.

Install and remove trailer hitch on blade

The trailer hitch is removable and can be installed only if needed. If the coupling device is removed a plug must be installed in the hole for normal machine operation on work side.

- 1 Park the machine on firm level ground.
- 2 Remove the plug (1) in the blade by opening the safety clip (2) on the back side and removing the bolt (3).

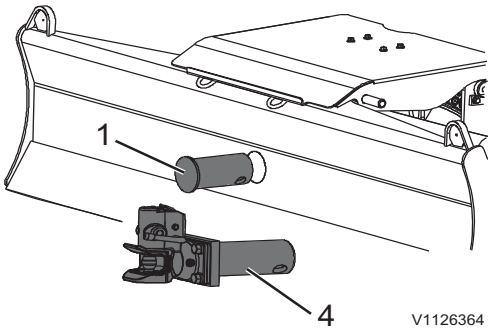

- 3 Install the trailer hitch (4) and secure it on the back side with the bolt (3) and the safety clip (2) from the plug.

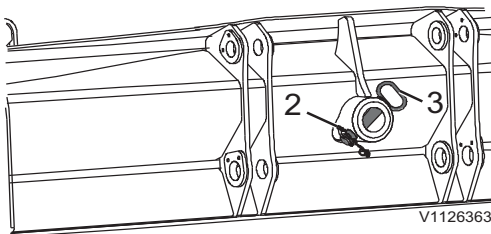

- 4 Stand on the right side of the blade hoist, right side means when facing the front side of the blade. Connect the mechanical fixation (5) behind the blade on the lower end of the blade hoist and secure it with the bolt (6).

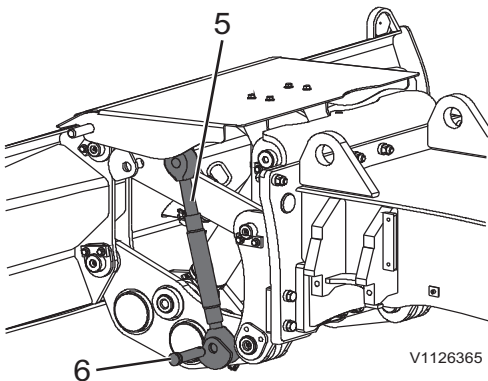

- 5 Install the safety clip (7) for the bolt (6) on the inner side of the blade hoist by reaching with your hands between the two mechanical parts (8).

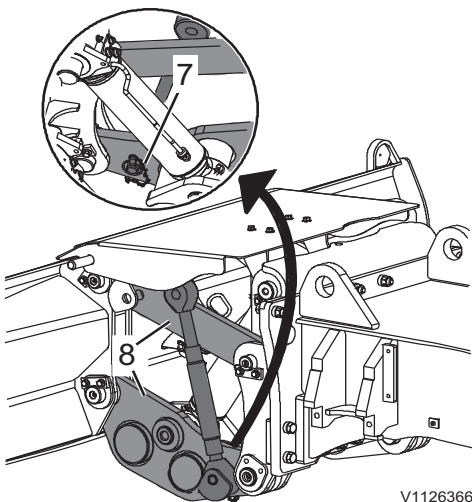

236 Operating techniques
Equipment towing

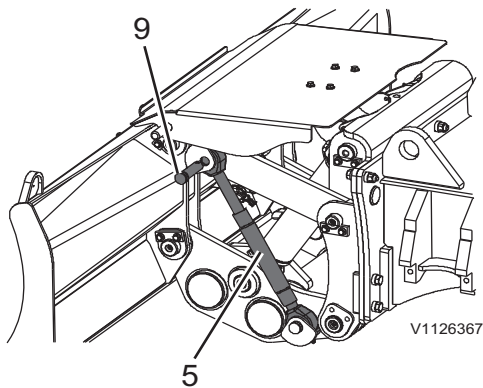

- 6 Connect the mechanical fixation (5) with the bolt (9) on the upper end of the blade hoist.

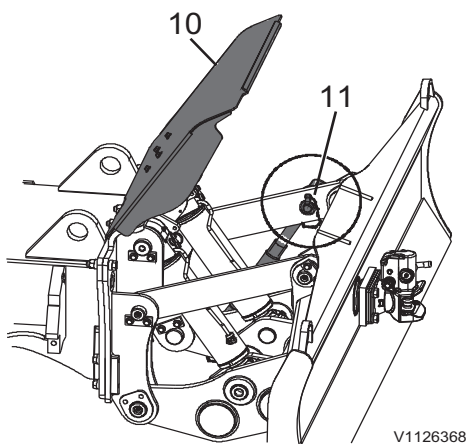

- 7 Stand in front of the blade. Lift the cover (10), hold it and secure the bolt with the safety clip (11). Lower the cover (10) slowly again afterwards.

NOTICE

Risk of machine damage.

Lowering or lifting the blade with mechanical fixation installed could damage the fixation and blade hoist.

Remove the mechanical fixation before lowering or lifting the blade.

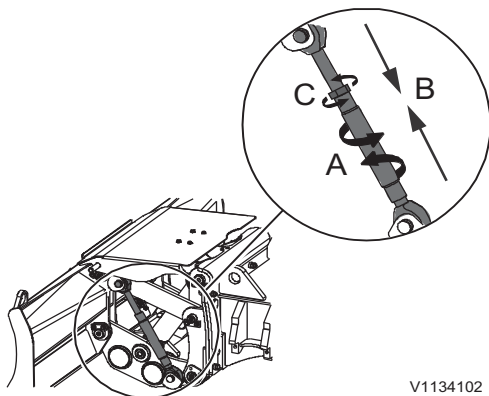

- 8 Tension the mechanical fixation without play by screwing it (A) in direction B and lock it with the lock nut (C).

- 9 If the trailer hitch is not needed, unlock and remove it and reinstall the plug (1) again. Also the mechanical fixation (5) must be removed in order to be able to use the blade for normal machine operation.

NOTE!

To remove the mechanical fixation you must loosen the lock nut (C) and loosen the tension (A) before removing it in the reverse order of the installation.

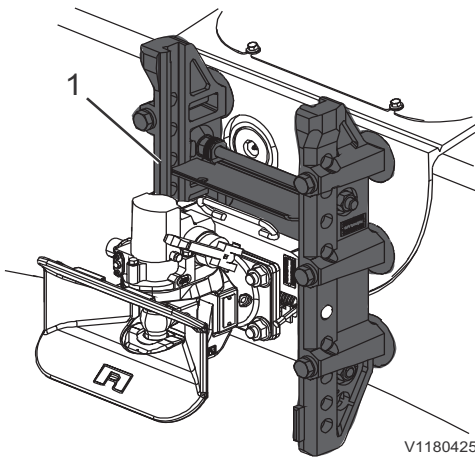

Hitch block

V1180425

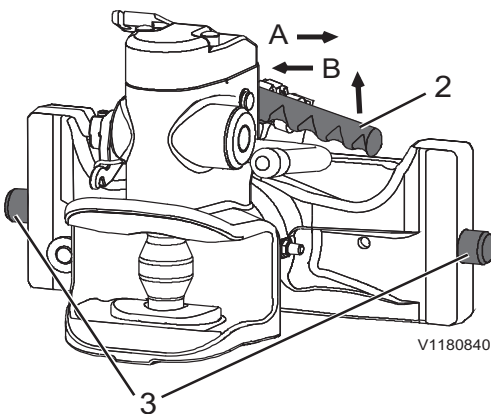

a) 40 mm drawbar eye
Trailer hitch coupling

V1180840

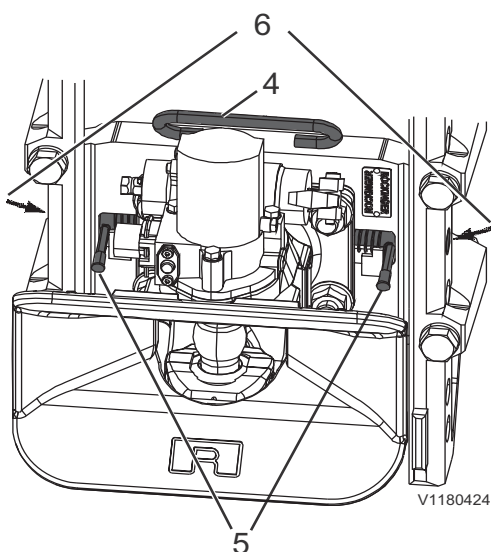

b) 50 mm drawbar eye
Trailer hitch coupling

V1180424

Install and remove trailer hitch on outrigger

The coupling part of the trailer hitch on the outrigger is removable and can be installed only if needed. The coupling device should be removed for normal machine operation on work side.

- 1 Park the machine on firm level ground.
- 2 Check the slip-through protection on the hitch block.
- 3 **a) For 40 mm drawbar eye trailer hitch:** Move both locking bolts (3) inside by putting the hand lever (2) up and then to the left (B).
- b) For 50 mm drawbar eye trailer hitch:** Move the locking bolt (6) on one side of the hitch inside with the small hand lever (5) and do the same on the other side.
- 4 Put the trailer hitch coupling from the top into the slideway of the hitch block (1).

NOTE!

Keep the coupling in your hand, do not use any tools to lock the coupling as this could damage the device.

5 Install

a) For 40 mm drawbar eye trailer hitch: Choose the required height for the coupling and put the hand lever (2) up and then to the right (A) to move the locking bolts (3) outside and lock the coupling device.

The coupling device is locked if the hand lever cannot be moved more than 4 mm (0,16 in) to the left.

b) For 50 mm drawbar eye trailer hitch: Hold the trailer hitch coupling on the handle (4) on top with one hand and choose the required height for the coupling. With the other hand pull the small hand lever (5) on one side of the hitch up, to the outside and then down to move the locking bolt (6) on one side of the hitch outside. Do the same with the small hand lever (5) on the other side to move the other locking bolt (6) outside.

NOTE!

Check that the trailer hitch coupling is correctly locked on the hitch block (1) before hitching a trailer to it.

6 Remove

a) For 40 mm drawbar eye trailer hitch: Pull the hand lever (2) up and then to the left (B) to move the locking bolts (3) on both sides of the hitch inside.

b) For 50 mm drawbar eye trailer hitch: Hold the trailer hitch coupling on the handle (4) on top with one hand. With the other hand pull the small hand lever (5) on one side of the hitch up, to the center and then down to move the locking bolt (6) on



one side of the hitch inside. Do the same with the small hand lever (5) on the other side to move the other locking bolt (6) inside.

Maintenance

For information about greasing of the trailer hitch see page 283. More information about the wear checking and maintenance of the trailer hitch can be found in the Service manual.

Hitching and unhitching a trailer

WARNING

Risk of accidents.

Towing a damaged trailer could lead to serious accidents.

Never tow any trailer if hitch and/or trailer show signs of damage.

Safety instructions for hitching and unhitching:

- The legal regulations for hitching and unhitching in the area where the machine is operated must be observed.
- Make sure the trailer has the allowed dimensions to tow it with your machine, check the specifications beforehand.
- Check the trailer voltage for the lights and direction indicators is 24 V DC and the trailer has a 7-pin connector.
- Use a signal man when hitching or unhitching a trailer.
- During hitching or unhitching, nobody is allowed to stand between the excavator and the trailer.
- Only carry out hitching or unhitching operations on firm level ground.
- Make sure the trailer hitch is installed correctly and not damaged.
- Check for visually damages on the trailer and the machines towing device.
- Never reach into the opened coupling with your hand.
- After every hitching operation the correct locked status of the trailer hitch must be checked, only drive the machine with the trailer if the hitch is correctly locked.

NOTE!

If the trailer requires a breakaway cable according to national regulations this must only be connected to the machine at the designated points A, B or C (see picture). Follow the instructions given in the documentation of the trailer.

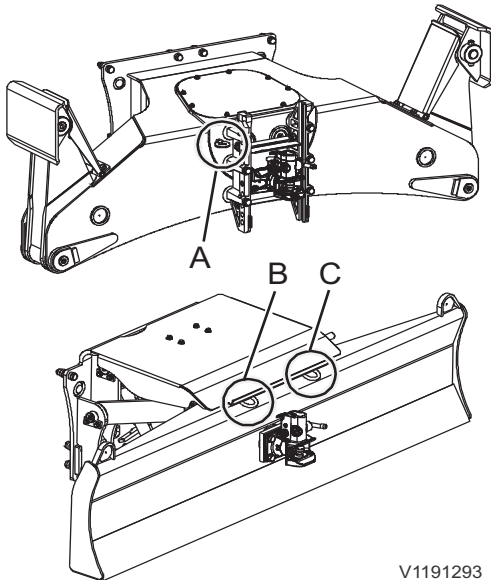

V1191293

240 Operating techniques Equipment towing

Hitching a trailer:

- 1 Read the safety instructions before hitching a trailer.
- 2 Place the drawbar eye at the centre of the jaw.

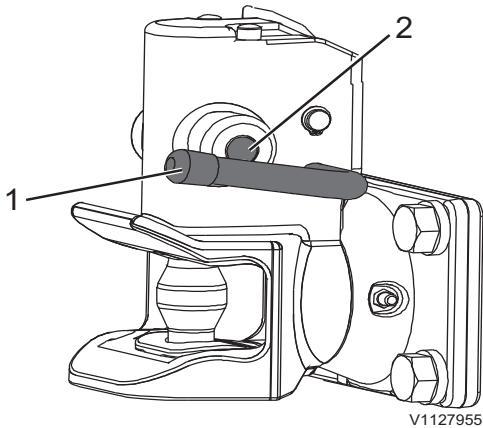

a) 40 mm drawbar eye
Trailer hitch blade

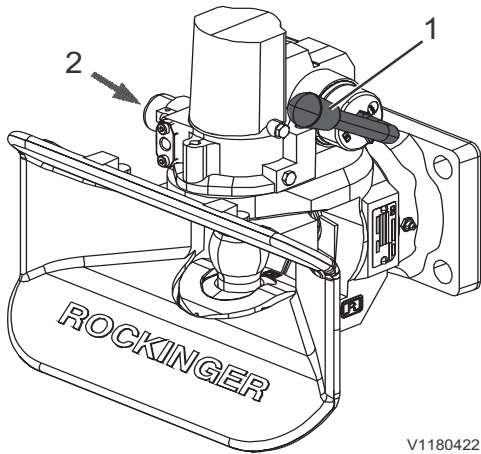

b) 50 mm drawbar eye
Trailer hitch blade

- 3 Press the hand lever (1) upwards until it engages.
- 4 Release the brake on the front axle of the steerable drawbar trailer.
- 5 When connecting with a rigid drawbar trailer, the drawbar eye must be as close to the centre of the jaw as possible, otherwise there is a risk of damage.
- 6 Reverse the excavator slowly.

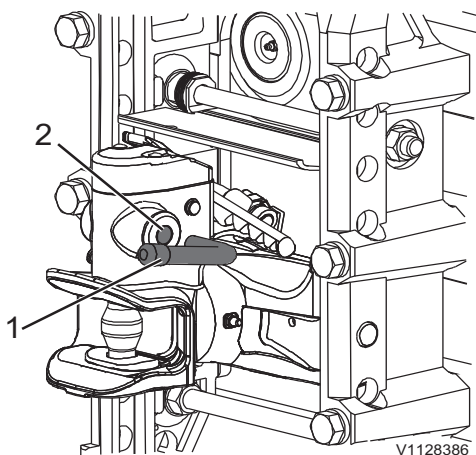

a) 40 mm drawbar eye
Trailer hitch outrigger

- 7 After hitching, the control pin (2) must not be visible outside of the control sleeve anymore. If it is not completely in, the trailer is not correctly attached.
In this case drive approx. 1 m (3 ft 3,4 in) forwards and then backwards and check the control pin again.
- 8 Connect the electric 7-pin connector for trailer lightning to the machine.
Make sure the connector is plugged in properly and check the functionality of the trailer lights and direction indicators.

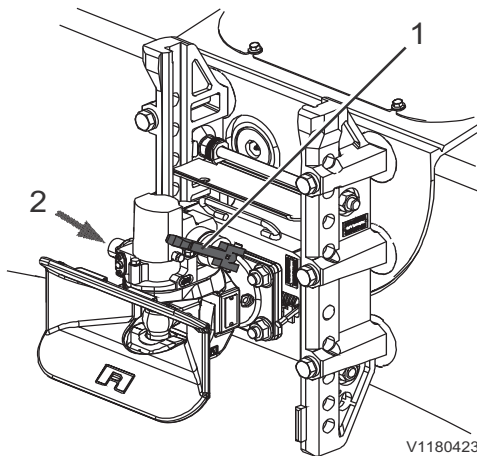

b) 50 mm drawbar eye
Trailer hitch outrigger

NOTE!

If one of the trailer direction indicator lights is damaged, the frequency of the direction indicator control lamp in the cabin is changing, see page 34.

- 9 Connect the hydraulic connector from the trailer hydraulics to the machine.
Make sure that the hydraulic connector is plugged in properly and there is no leakage.

NOTE!

When driving on public roads, travel mode must be engaged and mechanical fixation bracket must be installed on blade hoist if the trailer hitch is installed on the blade.

Unhitching a trailer:

- 1 Read the safety instructions before unhitching a trailer.
- 2 Make sure the dump trailer is not lifted when unhitching, it must be in the lowest position.
- 3 Secure the trailer against rolling away or extend support feet.
- 4 Remove the electric connector for the trailer lightning from the machine.
- 5 Remove the hydraulic connector of the trailer from the machine.
- 6 Open the coupling.
- 7 Move the excavator forwards.

NOTICE

Risk of machine damage.

The machine has a different behavior with a trailer attached and the different forces that occur while working with a trailer attached can damage the trailer and machine parts.

Always unhitch the trailer before working with the excavator.



242 Operating techniques
Equipment towing

Specification table for trailer towing

The trailer hitch is compatible with following tow bars with a diameter of 40 mm (1,58 in):

DIN11026-ISO5692-2

DIN11043

DIN74054-ISO8755

The trailer hitch is compatible with following tow bars with a diameter of 50 mm (1,97 in):

DIN74053-ISO1102

NOTE!

The maximum allowed axle loads by law can be below the maximum technical axle loads.

	EW160E – with 40 mm and 50 mm drawbar eye	EW180E – with 40 mm and 50 mm drawbar eye
D-Value	60 kN (13489 lbf)	60 kN (13489 lbf)
Max. vertical hitch load	1000 kg (2205 lb)	500 kg (1102 lb)
Max. trailer mass without brakes on trailer	3000 kg (6614 lb)	3000 kg (6614 lb)
Max. trailer mass with brakes on trailer	8000 kg (17637 lb)	8000 kg (17637 lb)
Height hitch blade *	500–830 mm (19,69–32,68 in)	500–750 mm (19,69–29,53 in)
Height hitch outrigger *	400–895 mm (15,75–35,24 in)	400–895 mm (15,75–35,24 in)
Hydraulic max. pressure	350 bar (5076 psi)	350 bar (5076 psi)
Hydraulic connector	ISO 7241–A ø 30 mm (ø 1,18 in)	ISO 7241–A ø 30 mm (ø 1,18 in)

* dependent on tyres

Signalling diagram

Manual signalling to an operator of a mobile excavator as per SAE J1307.

The primary use of hand signals is for a signalman to direct the lifting, handling, and placement of loads attached to working equipment. Hand signal usage may also be applicable to earth moving operations and/or machine travel when the operator's visibility is obstructed.

If a rapid lifting, lowering or moving movement is required, the dipper arm movements should be carried out more lively. If two different machines are used for lifting the same load, there should be an agreement beforehand how the lift should be carried out and what signals should be given to the respective operators.

<p>V1065920</p>	<p>V1065921</p>	<p>V1065923</p>
<p>RAISE LOAD VERTICALLY With either forearm vertical, forefinger pointing up, move hand in small horizontal circles.</p>	<p>LOWER LOAD VERTICALLY With either arm extended downward, forefinger pointing down, move hand in small horizontal circles.</p>	<p>MOVE LOAD IN HORIZONTALLY With either arm extended, hand raised and open toward direction of movement, move hand in direction of required movement.</p>
<p>V1065924</p>	<p>V1065925</p>	<p>V1065926</p>
<p>MOVE LOAD OUT HORIZONTALLY With either arm extended, hand raised and open toward direction of movement, move hand in direction of required movement.</p>	<p>RAISE BOOM With either arm extended horizontally, fingers closed, point thumb upward.</p>	<p>LOWER BOOM With either arm extended horizontally, fingers closed, point thumb downward.</p>
<p>V1065927</p>	<p>V1065928</p>	<p>V1065929</p>
<p>SLEW With either arm extended horizontally, point with forefinger to direction of slew rotation.</p>		<p>DIPPER ARM INWARD With both hands clenched, point thumbs inward.</p>
<p>V1065930</p>	<p>V1104049</p>	<p>V1104050</p>

Operating techniques
244 Signalling diagram

<p>DIPPER ARM OUTWARD With both hands clenched, point thumbs outward.</p>	<p>RETRACT TELESCOPIC BOOM With both hands clenched, point thumbs inward.</p>	<p>EXTEND TELESCOPIC BOOM With both hands clenched, point thumbs outward.</p>
<p>V1065931</p>	<p>V1065932</p>	<p>V1104051</p>
<p>CLOSE BUCKET Hold one hand closed and stationary. Rotate other hand in small vertical circle with forefinger pointing horizontally at closed hand.</p>	<p>OPEN BUCKET Hold one hand open and stationary. Rotate other hand in small vertical circle with forefinger pointing horizontally at open hand.</p>	<p>TURN Raise forearm with closed fist indicating inside of turn. Move other fist in vertical circle indicating direction of track or wheel rotation.</p>
<p>V1104052</p>	<p>V1065936</p>	<p>V1065937</p>
<p>TURN Raise forearm with closed fist indicating inside of turn. Move other fist in vertical circle indicating direction of track or wheel rotation.</p>	<p>COUNTER ROTATE Place hand on head indicating side or reverse track or wheel rotation. Move other hand in vertical circle indicating forward rotation of other track or wheel.</p>	
<p>V1065939</p>	<p>V1065940</p>	<p>V1065935</p>
<p>TRAVEL Raise forearm with closed fist indicating inside of turn. Move other fist in vertical circle indicating direction of track or wheel rotation.</p>		<p>THIS FAR TO GO With hands raised and open inward, move hands laterally, indicating distance to go.</p>
<p>V1065938</p>	<p>V1065941</p>	<p>V1065942</p>
<p>MOVE SLOWLY Place one hand motionless in front of hand giving motion signal. Raise load slowly is shown.</p>	<p>STOP With either arm extended laterally, hand open downward, move arm back and forth.</p>	<p>EMERGENCY STOP With both arms extended laterally, hands open downward, wave arms back and forth.</p>



Operating techniques
Signalling diagram 245

<p>V1065922</p>	<p>V1104053</p>	<p>V1104054</p>
<p>STOP ENGINE Draw thumb or forefinger across throat.</p>	<p>RETRACT TELESCOPIC DIPPER ARM With either arm outstretched horizontally in front of body, close fingers and point thumb in direction of required movement.</p>	<p>EXTEND TELESCOPIC DIPPER ARM With either arm outstretched horizontally in front of body, close fingers and point thumb in direction of required movement.</p>



Safety when servicing

This section deals with the safety rules which should be followed when checking and servicing the machine. It also describes the risks when working with unhealthy material and ways to avoid personal injuries.

Further safety rules and warnings texts are given within the respective sections.

WARNING

Risk of burns!

Hot machine parts could cause burns.

Allow hot machine parts to cool before performing adjustments or service. Wear personal protective equipment.

Service position

⚠ WARNING

Risk of burns!

Hot liquids and machine parts can cause burns.

Allow the machine to cool before beginning any service.

- 1 Park the machine horizontally on a firm and level ground.
The suitable position is indicated in the description for the various service jobs.

NOTICE

Before beginning any service work, the following measures must first be taken.

- 2 Apply the parking brake.
- 3 Turn off the engine and remove the ignition key.
- 4 During on-going service work, fasten a warning sign on the steering wheel with information that service is in progress.
- 5 Release the pressure from the hydraulic system, see page *Hydraulic system, releasing pressure*.

NOTE!

After pressure release, move the control lockout lever down and turn off the electrical power with the battery disconnect switch.

- 6 Block the wheels with suitable wheel chocks.
- 7 Allow the machine to cool down.

NOTE!

If no particular position is stated in the service chapter, the machine should be parked in service position A.

Service positions

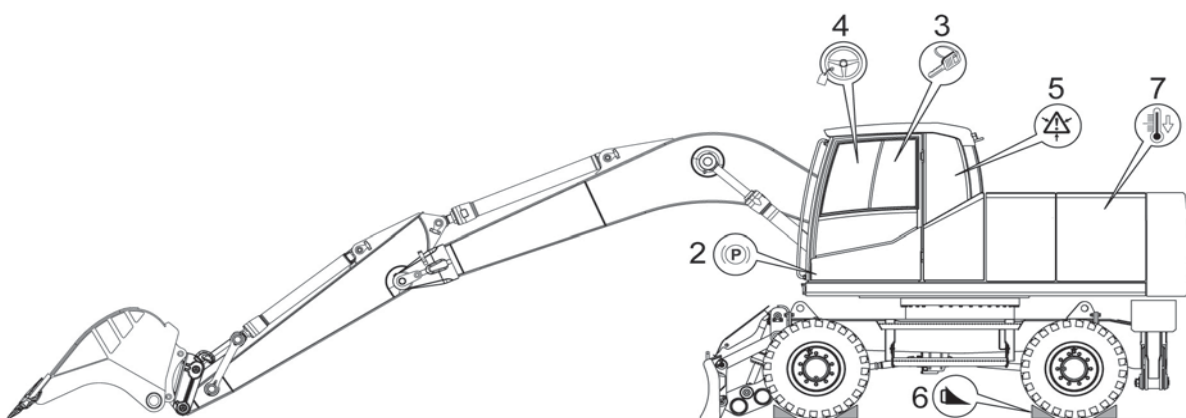

V1168525

Service position 1 (A)

248 Safety when servicing
Service position

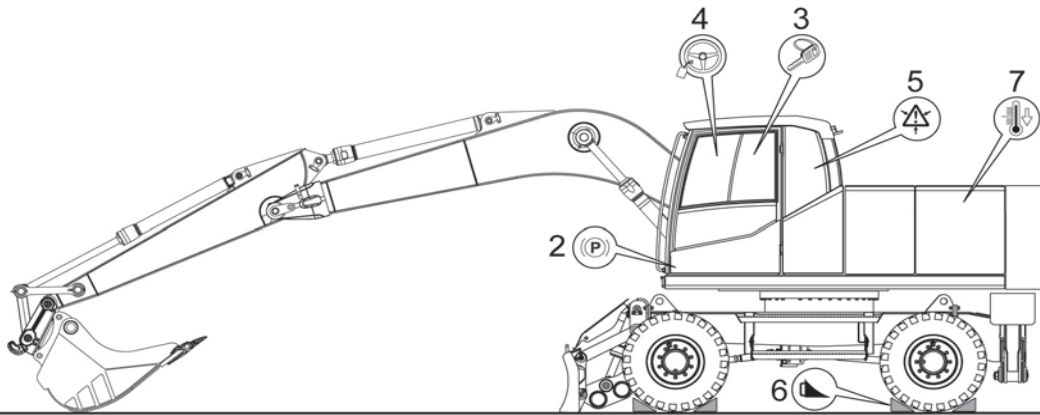

V1168526

Service position 2 (B)

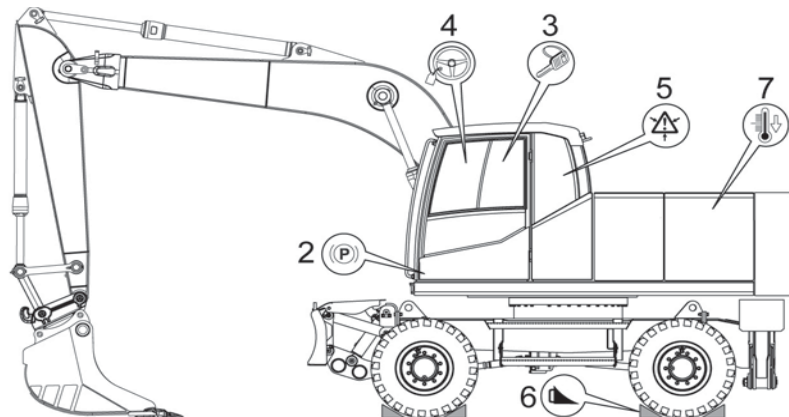

V1168526

Service position 3 (C)

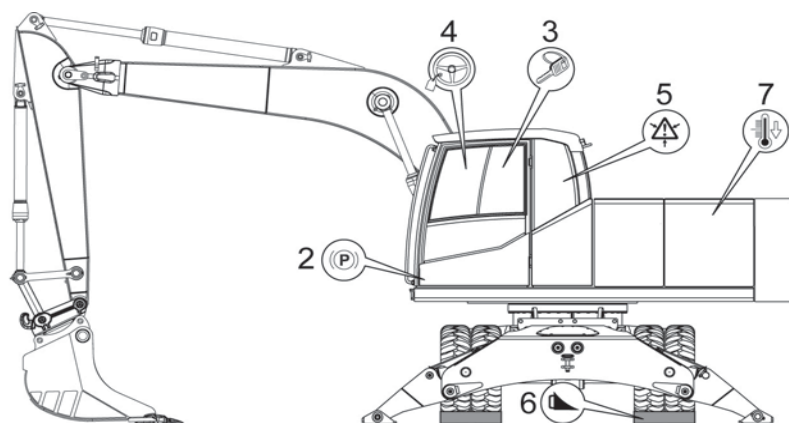

V1168528

Service position 4 (F)

Before service, read

Preventing personal injury

- Read the Operator's Manual before the service work is started. It is also important to read and follow information and instructions on plates and decals.
- Do not wear loose-fitting clothing or jewellery, which can get caught and cause injury.
- Always wear a hard hat, protective goggles, gloves, protective shoes and other protective articles when the work so requires.
- Make sure that the ventilation is sufficient when starting the engine indoors.
- Do not stand in front of or behind the machine when the engine is running.
- If service work has to be carried out under raised lifting arms, these must first be secured. (Engage the control lever lockout and apply the parking brake if the machine is equipped with one).
- Turn off the engine before opening the rear door and engine cover.
- When the engine is stopped, there is a remaining accumulated pressure in the pressurized systems. If a system is opened without having first released the pressure, liquid under high pressure will jet out.
- When checking for leaks, use paper or hardboard, not your hand.
- Make sure that stepping surfaces, handholds and anti-slip surfaces are free from oil, diesel fuel, dirt and ice. Never step on parts of the machine that are not intended for this.
- It is important to use correct tools and equipment. Broken tools or equipment should be repaired or changed.

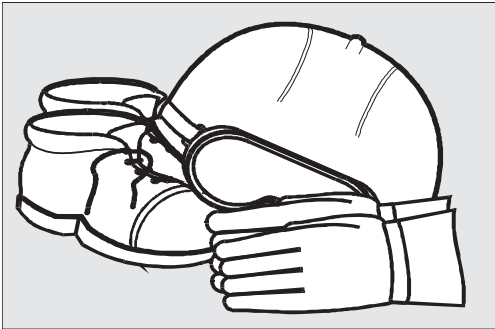

V1065951

**Preventing machine damage**

- When lifting or supporting the machine or parts of the machine, use equipment with a sufficient lifting capacity.
- Lifting devices, tools, working methods, lubricants and parts prescribed in the Operator's Manual should be used. Volvo Construction Equipment will not accept any responsibility otherwise.
- Make sure that no tools or other objects, which may cause damage, have been forgotten in or on the machine.
- Release the pressure in the hydraulic system before starting the service work.
- Never set a relief valve to a higher pressure than that recommended by the manufacturer.
- Machines, which are used within a polluted or in another way insanitary area should be equipped for this kind of work. Special safety regulations apply when servicing such a machine.
- When installing two-way radio, mobile telephone or similar equipment, the installation should be carried out in accordance with the manufacturer's instructions in order to eliminate interference with the electronic system and components intended for the function of the machine, see page 16.
- Measures to be taken in connection with electric welding, see page 307.
- Make sure that all covers on the machine are in position before the engine is started and the machine is put to work.



Preventing environmental influence

Be conscious of the environment when carrying out service and maintenance. Oil and other liquids dangerous to the environment and released into the environment will cause damage. Oil degrades very slowly in water and sediment. One litre of oil can destroy millions of litres of drinking water.

NOTE!

In common for all points below is that all waste is to be handed over to a treatment and disposal firm approved by the authorities.

- When draining, oils and liquids must be collected in suitable vessels and steps taken to avoid spillage.
- Used filters must be drained of all liquid before they are passed on as waste. Used filters from machines which work in environments with asbestos or other dangerous dust, must be placed in the bag supplied with the new filter.
- Batteries contain substances dangerous to the environment and health. Used batteries must therefore be handled as waste dangerous to the environment.
- Consumables, for example used rags, gloves and bottles may also be contaminated with oils and liquids dangerous to the environment and must in that case be treated as waste dangerous to the environment.

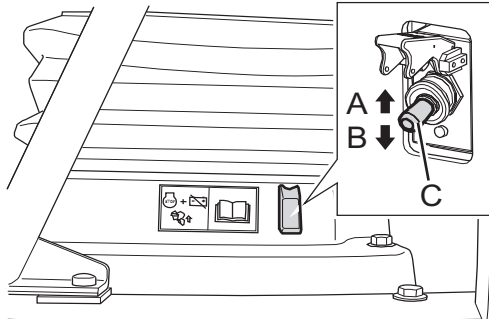

V1149247

- A OFF position
- B ON position
- C Battery disconnect switch

Battery disconnect switch

NOTICE

Do not turn off the battery disconnect switch when the engine is running. The electrical system may be damaged.

Battery disconnect switch (C) is located inside the cab. When welding, servicing of electrical system or after finishing work of the day for safety, the battery disconnect switch should be turned off.

NOTE!

Make sure that the indicator light goes out after turning off the battery disconnect switch. This may take a couple of minutes depending on the system status at the time.

Electrical system

For further information about the electrical system see page 340.

Electrical distribution box

Relays and fuses are in the electrical distribution box which is located inside the cab behind the operator seat.

NOTICE

Risk of fire.

An inappropriate fuse could result in damage or fire on the circuit board.

Never install a fuse with a higher amperage than what is stated on the decal.

Relays and fuses are easily accessible after removing the cover of the electrical distribution box. A decal which shows the exact positions and specifications of respective relays and fuses is provided on the inside of cover. For further specifications of relays and fuses see page 341.

NOTE!

If a fuse blows repeatedly in the same position, the cause of the fault has to be investigated.



Hydraulic system

NOTICE

Any work on the hydraulic system requires great demands on cleanliness. Even very small particles can cause damage or clog up the system. Therefore, wipe areas in question clean before any work is carried out.

The complete hydraulic system including the pressure-limiting valves is set to the correct values from factory.

For any work on the hydraulic system and on pressure-limiting valves the values and tolerances from the Volvo service manual must be applied, otherwise the guarantee from the manufacturer will be void.

Only a qualified service technician is allowed to work on the hydraulic system.



Hydraulic oil

NOTE!

Hydraulic oil is hazardous to the environment. Immediately use barriers to contain spilled oil and follow local regulations concerning hazardous materials.

NOTICE

Only hydraulic oil that is approved by Volvo may be used.

NOTICE

Use the same hydraulic oil that is already in the system. The hydraulic system may be damaged if different brands of hydraulic oil are mixed.

Hydraulic bio oil

- 1 When changing from a mineral oil to a bio oil, the oil must be drained as much as possible and it is required to flush the hydraulic system.
- 2 For the drain points and changing method, please contact the workshop authorized by Volvo Construction Equipment.

Entering, leaving and climbing the machine

Entering, leaving and climbing the machine

NOTICE

The safety regulations and operating instructions issued by the manufacturer must be strictly observed.

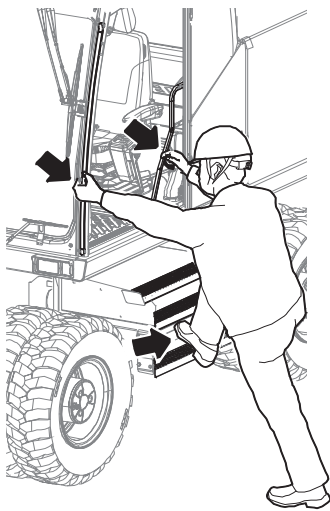

V1185228

Three-point grip

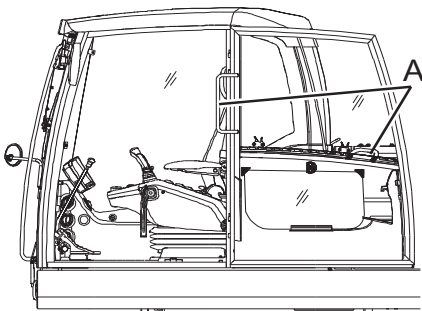

V1065947

A – hand grip on cab door

- Do not jump on/off a machine, especially never get on / off when the machine moves.
 - Never grasp the control lever to get on / off.
 - Use handholds and steps when entering, leaving or climbing the machine.
 - Use the three-point grip, that is two hands and one foot or two feet and one hand.
 - Always face the machine.
 - Always wipe mud and oil off all footboards, handrails and your footwear, especially clean the windows, rear view mirrors and lights.
 - Clean your boots and wipe your hands before getting on the machine.
-
- Do not use hand grip (A) of the cab door as a support when entering, leaving and climbing the machine. It is not strong enough to be used as a support, it should only be used for closing the door.
 - Do not hold the steering wheel inside the cab when getting on/off. It may cause problem to the parts by heavy side load.
 - Do not access to the bucket rest when getting on/off.

256 Safety when servicing Entering, leaving and climbing the machine

Climbing the machine for service work

- For service work that requires climbing on the machine either a personal fall arrest system (PFAS) or an external access system (e.g. portable working platform, stairway) must be used.

Consider national legislations and use only approved personal fall arrest systems and external access systems.

The personal fall arrest system (PFAS) must be connected to the external climbing fixture (B) next to the handhold at the rear side of the standard cabin or on the rear side of the tower for the elevating cab (depending on cab option).

NOTE!

Any repair work on the external climbing fixture (B) is forbidden. If damaged, it must be immediately replaced.

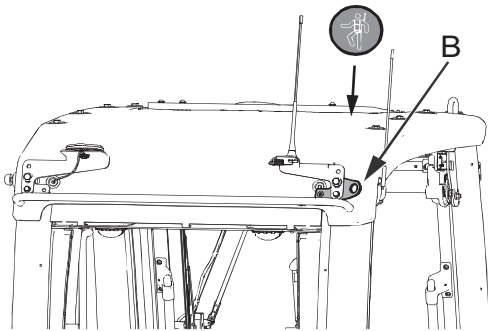

V1153820

B – external climbing fixture on standard cab machine

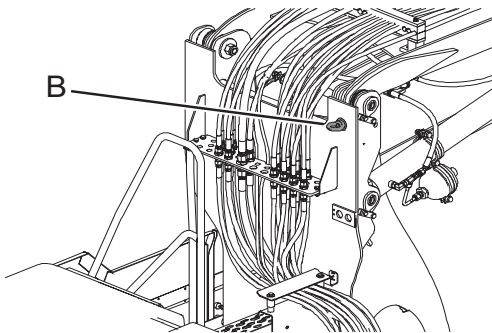

V1184627

B – external climbing fixture on hydraulic elevating cab machine



V1205601

Decal over external climbing fixture



Fire prevention

NOTE!

Using the machine in environments with high risk of fire or explosion requires special training and equipment.

There is always a risk of fire. Find out what kind of fire extinguisher is used on your working site and how to use it. If the machine is equipped with a fire extinguisher, it should be kept inside the cab, behind the operator seat.

If the machine is to be provided with a hand-held fire extinguisher, it should be of the ABE type (ABC in North America). The designation ABE means that it is possible to extinguish fires in both solid organic material and liquids, and that the fire extinguishing compound does not conduct electricity. Efficiency class I means that the effective operating time of the extinguisher must not be less than 8 seconds, class II at least 11 seconds and grade III at least 15 seconds.

A hand-held fire extinguisher ABE I normally corresponds to a powder content of 4 kg (8.8 lb) (EN-grade 13A89BC), standard EN 3.

Fire prevention measures

- Do not smoke or have an open flame near a machine when filling with fuel or when the fuel system is opened and in contact with the surrounding air.
- Diesel fuel oil is flammable and must not be used for cleaning. Use conventional car care products meant for cleaning or degreasing. Also bear in mind that certain solvents can cause skin rashes, damage to the paint finish and constitute fire hazard.
- Keep the place clean where the service is to be carried out. Oil and water can make the floor slippery and is also dangerous in connection with electrical equipment or electrically powered tools. Oily and greasy clothes are a serious fire hazard.
- Check daily that the machine and the equipment, for example underbelly plates are free from dust and oil. Besides reducing the risk of fire, it is also easier to detect faulty or loose components.

NOTE!

Take great care if a high-pressure wash is used for cleaning. Electrical components and electrical leads can be damaged even at a moderately high pressure and temperature. Protect electrical leads in an appropriate way.

- Take extra care when cleaning a machine working in a fire-sensitive environment, for example saw-mill and refuse dumps. The risk of spontaneous combustion can be further reduced by installing insulation of the silencer guard.
- It is important that the fire extinguisher is maintained in order to work when it is needed.
- Check that fuel lines, hydraulic and brake hoses and electrical cables have not been damaged by chafing or are not in danger of being damaged in that way because of incorrect installation or clamping. This applies particularly to unfused cables, which are red and marked R (B+) and routed:
 - between the batteries
 - between battery and starter motor
 - between alternator and starter motor
 Electrical cables must not lie directly against oil or fuel lines.
- Do not weld or grind on components which are filled with flammable liquids, for example tanks and hydraulic pipes.



Exercise care with such work also in the proximity of such places. A fire extinguisher should be kept near to hand.

Actions in case of fire

If the circumstances permit and your own safety is not jeopardised, take the following steps at the slightest sign of fire:

- 1 Stop the machine, if the machine is in motion.
- 2 Lower attachments to the ground.
- 3 Move the control lockout lever to locked position, if so equipped.
- 4 Turn the ignition switch to stop position.
- 5 Exit the cab.
- 6 Call the fire brigade.
- 7 If possible to access safely, turn off the battery disconnect switch.
- 8 Attempt to put out the fire, if possible. Otherwise, move away from the machine and out of the danger zone.

Actions after fire

When handling a machine which has been damaged by fire or been exposed to intense heat, the following protective measures must be followed:

- Use thick, protective gloves made of rubber and wear goggles.
- Never touch burnt components with your bare hands in order to avoid contact with melted polymer materials. First wash thoroughly with plenty of lime water (a solution consisting of calcium hydroxide, that is slaked lime in water).
- Handling heated fluoro-carbon rubber, see page 259.

Handling hazardous materials

Heated paint

WARNING

Risk of toxin inhalation.

Burning of painted, plastic or rubber parts produces gases that could damage respiratory tracts.

Never burn painted or rubber parts or any plastics.

Heated paint gives off poisonous gases. Therefore, paint must be removed from an area with a radius of at least 10 cm (4 in) before carrying out welding, grinding or gas cutting. In addition to the health hazard, the weld will be of inferior quality and strength, which, in the future, may cause the weld to break.

Methods and precautionary measures when removing paint

- Blasting
 - use respiratory protective equipment and protective goggles
- Paint remover or other chemicals
 - use a portable air extractor, respiratory protective equipment and protective gloves
- Grinding machine
 - use a portable air extractor, respiratory protective equipment and protective gloves and goggles

Never burn painted parts after they have been discarded. They should be disposed of by a licensed disposal plant.

Heated rubber and plastics

Polymer materials can, when heated, form compounds which are dangerous to health and environment and must therefore never be burned when scrapped.

If gas cutting or welding is to be carried out near such materials, the following safety instructions must be followed:

- Protect the material from heat.
- Use protective gloves, protective goggles and respiratory protective equipment.

Heated fluoro-carbon rubber

WARNING

Risk of serious injury.

At very high temperatures fluoro-carbon rubber forms substances which are very corrosive to skin and lungs.

Always wear personal protective equipment.

When handling a machine which has been damaged by fire or been exposed to intense heat, the following measures should be taken:

- Use thick, rubber gloves and wear protective goggles.
- Discard gloves, rags and other items that have been in contact with heated fluoro-carbon rubber after first having washed these items in lime water (a solution of calcium hydroxide, that is slaked lime in water).
- The area around a part which has been very hot and which may be made of fluoro-carbon rubber should be decontaminated by thorough and ample washing with lime water.
- As a precaution, all seals (O-rings and other oil seals) should be handled as if they were made of fluoro-carbon rubber.



- The hydrofluoric acid may remain on the machine parts for several years after a fire.
- If swelling, redness or a stinging feeling appears and one suspects that the cause may be contact with heated fluoro-carbon rubber, contact a medical doctor immediately. Several hours may pass, however, before any symptoms appear and there is no immediate warning.
- The acid cannot be rinsed or washed off from the skin. Treat instead with Hydrofluoric Acid Burn Jelly or similar before contacting a medical doctor.

Crystalline silica (quartz) dust

WARNING

Risk of hazardous inhalation.

Working in environments containing dangerous dust can lead to serious health problems.

Wear personal protective equipment when working in dusty environments.

Crystalline silica is a basis component of sand and granite. Therefore, many activities at construction and mining sites, such as trenching, sawing and boring, produce crystalline silica dust. This dust can cause silicosis.

The employer or working site management should provide the operator with information about the presence of crystalline silica in the work site along with specific work instructions and precautions and also necessary personnel protection equipment. Also check the local / national regulations regarding silica / silicosis.



Batteries

WARNING

Risk of chemical burns.

The battery electrolyte contains corrosive sulphuric acid which could cause severe chemical burns.

If electrolyte spilled on your bare skin, remove it immediately and wash the affected area with soap and plenty of water. If it gets into your eyes or any other sensitive body part, rinse with plenty of water and seek immediate medical attention.

- Do not smoke near batteries as these give off explosive gases.
- Make sure that metal objects, for example tools, rings and watch straps, do not come into contact with the battery pole studs.
- Make sure the protections are always installed over the battery pole studs.
- Do not tilt a battery in any direction. Battery electrolyte may leak out.
- Do not connect a discharged battery in series with a fully charged battery. Risk for explosion.
- When removing a battery, disconnect the ground cable first and when installing, connect the ground cable last in order to reduce the risk of sparks.
- Discarded batteries must be taken care of according to national environmental requirements.
- Charging batteries, see page 306.
- Starting with booster batteries, see page 155.



Refrigerant

Environmental precautions

The air conditioning system of the machine is filled with R134a refrigerant at the factory. R134a refrigerant is a fluorinated greenhouse gas and contributes to global warming.

Do not release refrigerant into the environment. See page 348 for the amount of R134a refrigerant in your machine and its global warming potential.

Safety precautions

Work on the air conditioning system must only be performed by a qualified service technician. Do not attempt to perform work on the air conditioning system.

Wear safety goggles, chemical resistant gloves (e.g., neoprene or butyl rubber) and appropriate personal protective equipment to protect bare skin when there is a risk of contact with refrigerant.

Actions in case of exposure

Eye contact: Rinse with warm water and apply a light bandage. Seek medical attention immediately.

Limited skin contact: Rinse with warm water and apply a light bandage. Seek medical attention immediately.

Extensive skin contact: Rinse with warm water and carefully heat the area with warm water or warm clothing. Seek medical attention immediately.

Inhalation: Leave the area and find fresh air. Seek medical attention immediately.



Handling line, tubes and hoses

WARNING

Risk of high pressure injection.

Leaks from high pressure hoses could cause serious injury to skin and eyes.

If high pressure hoses are loose or leaking, contact a qualified service technician.

Keep away from fluid that is spraying out.

Use a stiff piece of cardboard to check for leaks. Never use your hands to check for leaks.

- Do not bend high pressure lines.
- Do not strike high pressure lines.
- Do not install any lines that are bent or damaged.
- Check lines, tubes and hoses carefully.
- Do not reuse hose, tube and fittings.
- Do not use your bare hand to check for leaks.
- Tighten all connections. Contact an authorized dealer for information about the recommended tightening torque.

The parts must be replaced if any of the following conditions are found. Contact a qualified service technician.

- End fittings are damaged or leaking.
- Outer coverings are chafed or cut.
- Strengthening wires are exposed.
- Outer coverings are ballooning.
- Flexible part of the hoses are kinked.
- End fittings are displaced.
- Foreign material is embedded in the coverings.

NOTICE

Make sure that all clamps, guards and heat shields are correctly installed. This contributes to preventing vibrations, chafing against other parts and excessively strong generation of heat.



Maintenance

This section describes the scheduled maintenance intervals for the machine and provides instructions for maintenance procedures which the operator may perform. See page 268 for a complete list of the scheduled maintenance intervals. Items that refer to the Service Manual must be performed by a qualified service technician.

The scheduled maintenance intervals must be performed as specified in order to maintain the machine for maximum reliability and performance.

Lubrication and service chart

The section "Lubrication and service chart" describes the maintenance work which the operator can carry out. If certain operations require trained workshop personnel and special equipment, this will be indicated.

Service history

After each completed service by a qualified service technician, the service history should be filled in, see page 406. Service history is a valuable document, which is referred to when selling the machine.

Arrival Inspection

Before the machine leaves the factory, it is tested and adjusted. The dealer or distributor must also carry out arrival inspections according to the applicable form.

Delivery Inspection

Before the machine leaves the factory, it is tested and adjusted. The dealer or distributor must also carry out delivery inspections according to the applicable form.

Delivery Instructions

When handing the machine over, the dealer must give the buyer delivery instructions according to the applicable form, which must be signed, if the warranty is to apply.

Service Programme

For any factory warranty to be valid, the machine shall be maintained according to the service program established by Volvo. The service program is continuous with fixed intervals. The operating time between intervals only applies if the machine is used in normal environment and operating conditions. Ask your Volvo dealer what is right for your specific machine.

There is one inspection in addition to the continuous program, a first inspection at the first 500 hours. This inspection shall be performed by a qualified service technician.

Service points

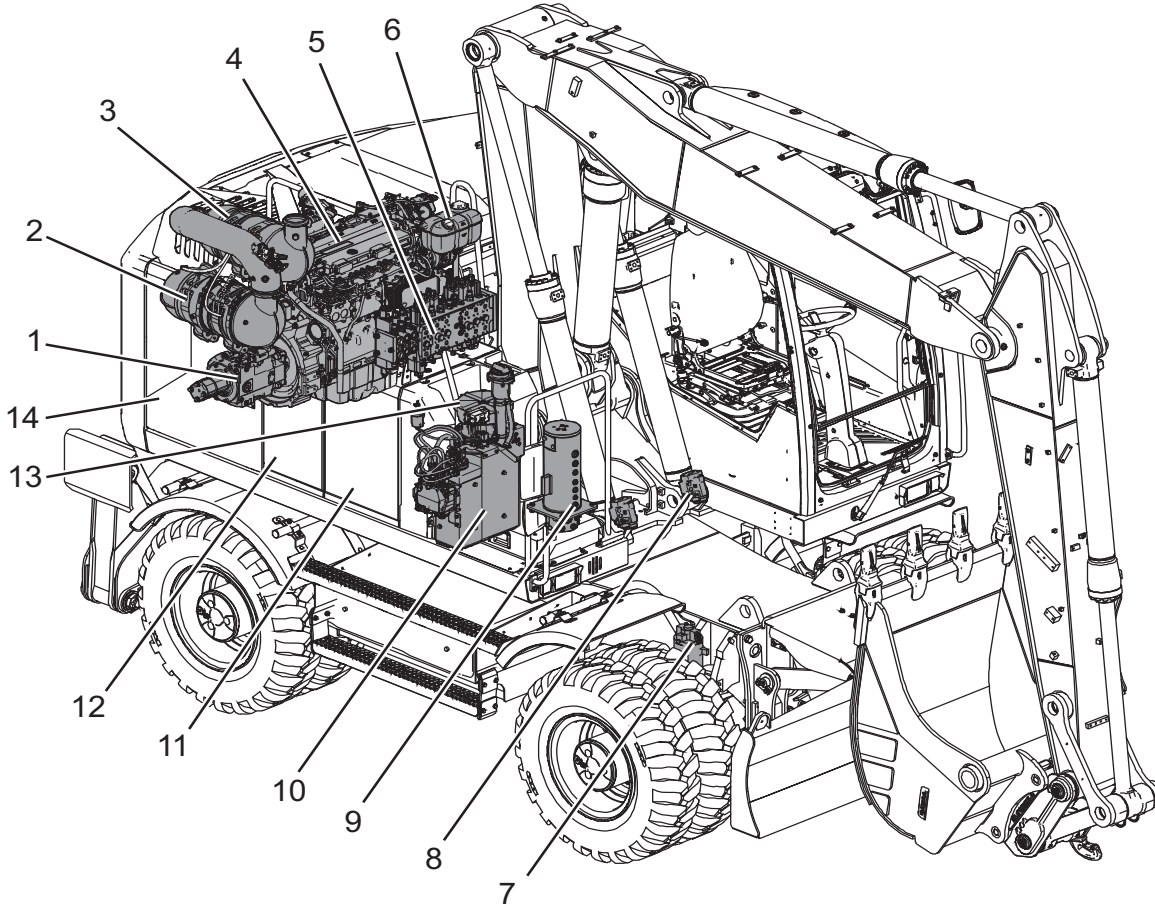

V1150320

1.	Main pump	8.	Line (hose) rupture valves
2.	DPF muffler (diesel particulate filter)	9.	Center passage
3.	SCR muffler (selective catalytic reduction catalyst)	10.	AdBlue®/DEF tank
4.	Engine	11.	Fuel tank
5.	Main control valve	12.	Hydraulic oil tank
6.	Expansion tank	13.	Swing unit
7.	Pivot axle locking cylinder	14.	Primary fuel filter with water trap

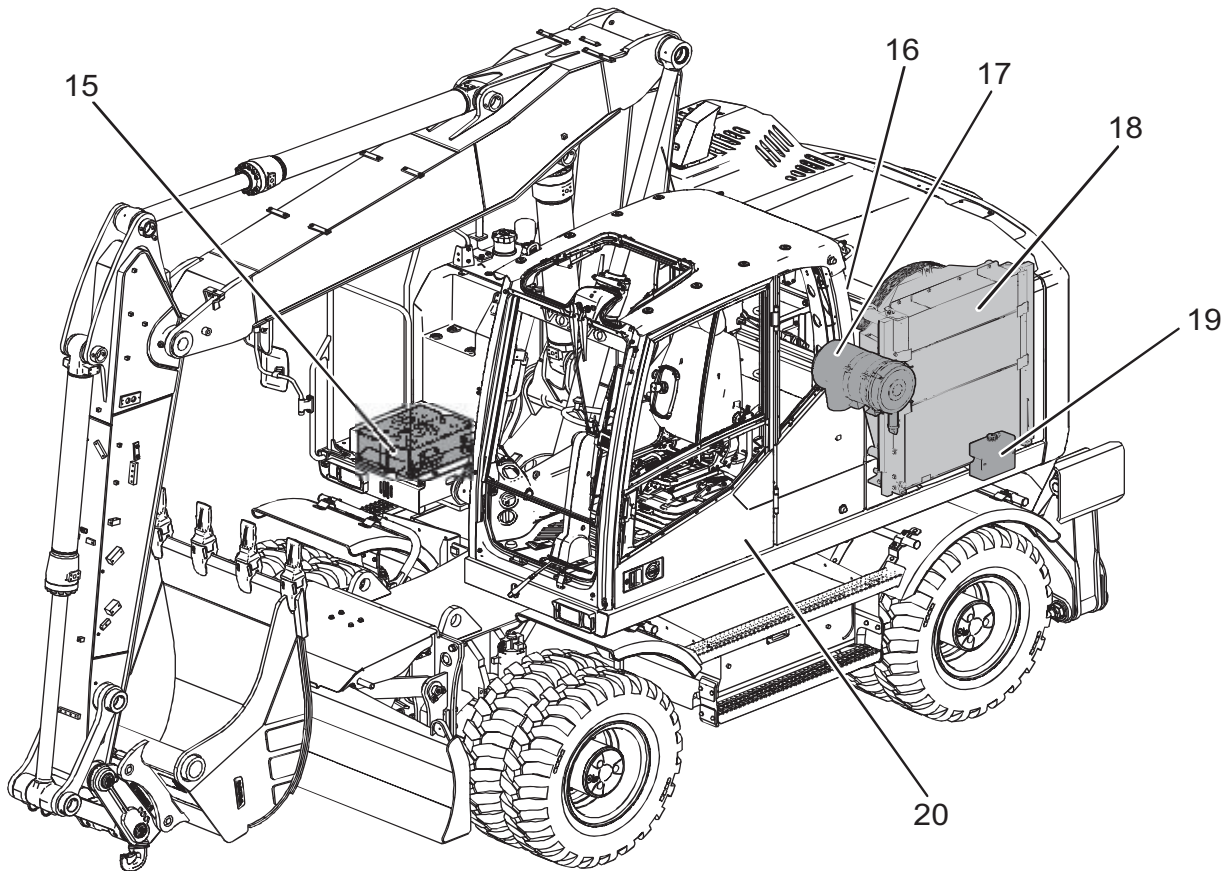

V1150321

15.	Batteries	18.	Radiator and charge air cleaner
16.	Cab prefilter	19.	Windscreen washer water tank
17.	Engine air cleaner	20.	Battery disconnect switch

Lubrication and service chart

Lubrication

Lubrication is an important part of preventive maintenance. The service life of bushings, bearings and bearing pins can be extended considerably if the machine is lubricated in a correct way. A lubrication chart makes lubrication work easier and reduces the risk of forgetting greasing points.

Lubrication has two main purposes:

- To supply grease to the bearing in order to reduce wear between the pin and the bearing.
- To replace old and dirty grease. The grease stored inside the outer seal collects dirt and water and prevents them from penetrating into the bearing.

NOTICE

Wipe off grease nipples and grease gun before greasing, so that dirt and sand are not introduced through the grease nipples into the bearings.

Symbol key

The following standard symbols are used in the lubrication and maintenance chart.



V1072393

Engine



V1072394

Swing drive unit



V1072395

Hydraulic system



V1072396

Tyres



V1072397

Axles
Travel gearbox



V1072398

Fuel system



V1072399

Battery



V1072400

Coolant



V1072401

Cab



V1072402

Brakes



V1072402

Lubrication



V1072404

Oil/liquid



V1072405

Filters



V1072406

Air filter



V1072407

Level check



V1072408

Water separator (drain)



V1072409

Clean (air)



V1072410

Visual checks



V1072411

Belts (check)

Lubrication and service chart

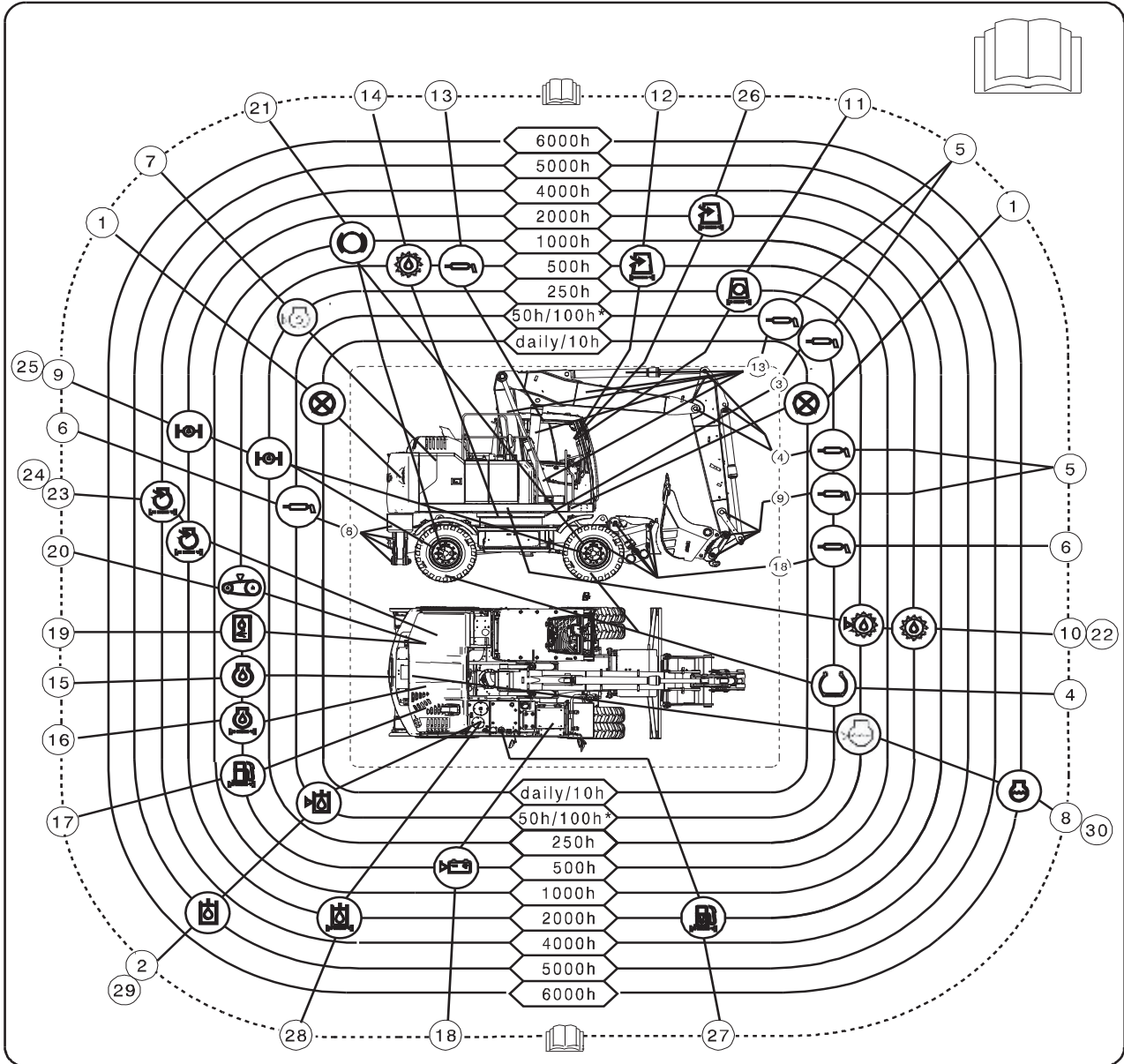

V1179927

(Items 10 and 22 are not valid for EW160E)

NOTE!

The service history on page 406 must be filled in after each service from 500 hours.

DAILY (every 10 hours)	Item	Page
Test running and checking	1	273
Leakage checking	1	274
Lubrication 10 hours (only during the first 100 hours)	—	274, 274



270 Maintenance
Lubrication and service chart

Every 50 hours (after carrying out daily services)	Item	Page
Hydraulic oil level, checking	2	276
Tyre wear and air pressure, checking	4	275
Lubrication 50 hours	5	278, 281

Every 100 hours (after carrying out daily and 50 hours services)	Item	Page
Lubrication 100 hours	6	283

Every 250 hours (after carrying out daily and 50 hours services)	Item	Page
Engine oil level, checking	7	287
Coolant level, checking	8	288
Drive axles and hubs oil level, checking	9	292
Travel gearbox oil level, checking	9	292
Swing gearbox oil level, checking (except EW160E)	10	291
Cab prefilter, cleaning	11	294

First 500 hours (after carrying out daily, 50 and 250 hours services)	Item	Page
Swing gearbox oil changing (except EW160E) (Change once after the first 500 hours and then every 1000 hours.)	—	Workshop job
Hydraulic oil return filter, replacing (Replace once after the first 500 hours and then every 2000 hours.)	—	Workshop job
Hydraulic oil servo filter, replacing (Replace once after the first 500 hours and then every 2000 hours.)	—	Workshop job
In-line hydraulic oil filter, cleaning (Clean once after the first 500 hours and then every 2000 hours.)	—	Workshop job
Hydraulic oil drain filter, replacing (Replace once after the first 500 hours and then every 2000 hours.)	—	Workshop job

Every 500 hours (after carrying out daily, 50, 100 and 250 hours services)	Item	Page
Cab main filter, cleaning (a)	12	297
Cab main HEPA filter (optional, see information on decal on air conditioning unit), replacing.		Workshop job
Hinge, lubrication	13	295
Swing ring gear lubrication, checking	14	Workshop job
Trailer hitch, checking (optional equipment)	—	Workshop job
Diesel particulate filter, regenerating	—	Workshop job
Engine oil and filter, changing (Changing intervals vary according to oil grade and sulfur content in fuel, see page 327.)	15/16	Workshop job
Fuel filters, replacing	17	Workshop job
Battery, checking	18	295
Radiator, cleaning	19	298



Maintenance
Lubrication and service chart **271**

Every 500 hours (after carrying out daily, 50, 100 and 250 hours services)	Item	Page
Air conditioner compressor belt, check	20	Workshop job
Universal attachment quick coupler (optional equipment), checking	—	298

a) Cab main HEPA filter (optional) must not be cleaned, see information on decal on air conditioning unit

Every 1000 hours (after carrying out daily, 50, 100, 250 and 500 hours services)	Item	Page
Overload warning system, checking	—	300
Engine belt tension, checking	—	Workshop job
Wheel nuts torque, checking	—	300
Brake pressure and function, checking	21	Workshop job
Brake disc wear, measuring (At least once a year.)	21	Workshop job
Swing gearbox oil changing (except EW160E)	22	Workshop job
MATRIS and Tech Tool reading	—	Workshop job
Software update, checking (At least once a year.)	—	Workshop job

Every 2000 hours (after carrying out daily, 50, 100, 250, 500 and 1000 hours services)	Item	Page
Engine air cleaner primary filter, replacing (At least once a year or when indicated.)	23	Workshop job
Drive axles and hubs oil, changing (Changing intervals vary according to load class, see page 327.)	25	Workshop job
Travel gearbox oil, changing (Replace at least once a year.)	25	Workshop job
Cab prefilter, replacing	26	Workshop job
Cab main filter, replacing (Optional cab main HEPA filter must be replaced every 500 hours, see information on decal on air conditioning unit.)	26	Workshop job
Fuel tank breather filter, replacing	27	Workshop job
Hydraulic oil tank breather filter, replacing	28	Workshop job
Hydraulic oil return filter, replacing	28	Workshop job
Hydraulic oil servo filter, replacing	28	Workshop job
In-line hydraulic oil filter, cleaning	28	Workshop job
Hydraulic oil drain filter, replacing	28	Workshop job
Coolant freezing point, checking (At least once a year.) See pages 301 and 331 for coolant and water specifications.	—	Workshop job
Valves, adjusting	—	Workshop job
Boom suspension accumulator, checking (optional equipment) (At least once a year.)	—	Workshop job

Every 4000 hours (after carrying out daily, 50, 100, 250, 500, 1000 and 2000 hours services)		
Engine air cleaner secondary filter, replacing (Replacing every 3rd main filter is replaced or every 2nd year.)	24	Workshop job



272 Maintenance
Lubrication and service chart

Every 5000 hours (after carrying out daily, 50, 100, 250, 500 and 1000 hours services)		
Hydraulic oil, changing (Changing intervals vary according to type of oil, see page 327.)	29	Workshop job

Every 6000 hours (after carrying out daily, 50, 100, 250, 500, 1000 and 2000 hours services)	Item	Page
AdBlue®/DEF pump unit filter, replacing	—	Workshop job
AdBlue®/DEF tank, breather filter, replacing (At least every 4th year.)	—	Workshop job
Coolant, changing (At least every 4th year.)	30	Workshop job

Every 8000 hours (after carrying out daily, 50, 100, 250, 500, 1000, 2000 and 4000 hours services)	Item	Page
Diesel particulate filter, checking and cleaning	—	Workshop job

Maintenance when required
See chapter “Maintenance when required” on page 302 and following.



Maintenance service, every 10 hours

Test-run and check

Perform the test-run and check daily.

NOTE!

Contact a qualified service technician if there is a problem with any of the following items.

NOTE!

Read the safety when servicing instructions before starting any work.

Decals, plates and reflectors

- 1 Check that all decals and plates are in place, are legible, and are not damaged. For the correct position, see page 19.
- 2 Check that all reflectors are in place and not damaged.

External check

- 1 Check that the superstructure, undercarriage and attachment are free from external damages, cracks, wear damages and loose parts. Especially tires, hoses and pipes.
- 2 Inspect steps and handholds for damage or loose parts.
- 3 Check that all lights, mirrors and windows are clean and intact. Clean/scrape off ice if required.
- 4 Check that the cameras are clean and intact.
- 5 Check the access routes for maintenance.
- 6 Check the washer fluid level and add washer fluid as needed, see page 274.
- 7 Clean the dust around the engine, battery and cooler.
- 8 Check that there is sufficient fuel in the tank.

Test-run

- 1 Check the position of the mirrors and the function of the cameras.
- 2 Check that the seat belt can be fastened and is not damaged, see also page 117 for seat belt maintenance.
- 3 Check the start and stop functions including the pre-heating function.
- 4 Check the function of all lights, direction indicators and hazard flashers.
- 5 Check the function of all instruments in the cab.
- 6 Check the engine oil level in the display.
- 7 Check the function of the warning system.
- 8 Check the function of the horn.
- 9 Check the function of wipers and washers.
- 10 Check the function of the climate control system.
- 11 Check the function of the steering system.

274 Maintenance Maintenance service, every 10 hours

12 Check the function of the service brake, digging brake and parking brake.

13 Check the function of the attachment quick coupler (optional equipment).

Leakage, checking

Perform the leakage check daily.

NOTE!

Read the safety when servicing instructions before starting any work.

- 1 Place the machine in service position B, see page 247.
- 2 Check that the engine and the AdBlue®/DEF and Exhaust aftertreatment system are free from leakage.
- 3 Check that all hydraulic components are free from leakage.
- 4 Check that the drive line is free from leakage.

Washer reservoir

Check the fluid level daily.

NOTE!

Read the safety when servicing instructions before starting any work.

The washer reservoir is located behind the left-hand side cover.

NOTE!

When the temperature is below freezing point, anti-freeze should be added to the washer fluid. Follow the manufacturer's recommendations as regards the ambient temperature.

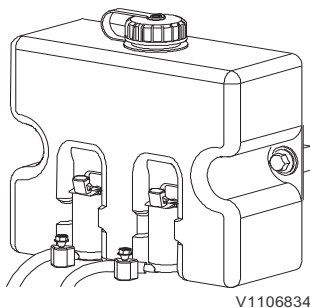

Washer reservoir

Excavator unit, greasing

Grease the excavator unit every 10 hours or daily only during first 100 hours. After first 100 hours of operation, grease the excavator unit every 50 hours or weekly.

See page 278.

Remote greasing nipples

Grease the remote greasing nipples every 10 hours or daily only during first 100 hours. After first 100 hours of operation, grease the remote greasing nipples every 50 hours or weekly.

See page 281.

Maintenance service, every 50 hours

Tyres, wear and air pressure, checking

Check the tyres (wear and air pressure) every 50 hours.

NOTE!

Read the safety when servicing instructions before starting any work.

! WARNING

Risk of explosion.

Inflating a tyre could cause it to explode. An exploding tyre could lead to lethal injuries.

Use a self-attaching air chuck with a hose long enough to enable the tyre to be inflated without standing in front of the rim and as far away as possible. Make sure no one stands in front of, or passes, the rim during inflation.

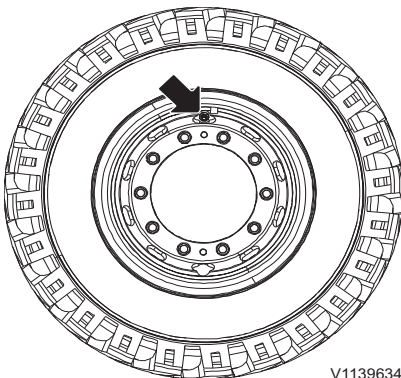

V1139634

Tyre inflation valve at 12 o'clock

- 1 Park the machine on level ground with the wheel rotated so that the tyre inflation valve is located at the 12 o'clock position. The tyre should be cold and the machine without load.
- 2 Select Mode W or C on the mode selector and turn off the engine, apply the parking brake and remove the ignition key.
- 3 Remove the tyre inflation valve cap.
- 4 Check the pressure in each tyre with an appropriate tyre gauge, for the correct tyre pressure see page 344.
- 5 After checking the tyre pressure, place the valve caps to prevent dirt, moisture and foreign material from damaging the valve core.
- 6 Check the tyre for visible defects such as cuts, punctures, bulges, leaks, excessive wear or cracking.
- 7 Check the wheel rim for excessive rust, cracks, missing or loose wheel bolts, or other damage which could cause premature tyre wear or failure.
Report tyre and wheel rim defects to a qualified person who is equipped and trained to perform tyre repair service. Repair work on tyres and rims must only be carried out by persons who have been especially trained for this.

NOTE!

The wheel nuts must be checked every 1000 hours, read information on page 300.

Maintenance
276 Maintenance service, every 50 hours

Hydraulic oil level, checking

Check the hydraulic oil level every 50 hours.

NOTE!

Read the safety when servicing instructions before starting any work.

WARNING

Risk of burns!

Hot liquids and machine parts can cause burns.

Allow the machine to cool before beginning any service.

- 1 Place the machine in service position B, see page 247. If the machine is equipped with four stabiliser legs, two should be up and two should be down. If the machine is equipped with stabiliser blade only, the blade should be down.
- 2 Press the knob (2, rubber cap) on top of the hydraulic tank a couple of seconds to release the tank pressure.
- 3 Open the right-hand side cover and check the oil level in the level gauge (3).
If the level is between the lower limit line and the upper limit line of the gauge, the level is correct.
- 4 In case of low level, remove the plug (1) and top up with hydraulic oil.

NOTE!

Only hydraulic oil that is approved by Volvo may be used.

Use the same hydraulic oil that is already in the system. The hydraulic system may be damaged if different brands of hydraulic oil are mixed.

NOTICE

Any work on the hydraulic system requires great demands on cleanliness. Even very small particles can cause damage or clog up the system. Therefore, wipe areas in question clean before any work is carried out.

NOTICE

Risk of environmental pollution.

Hydraulic oil is hazardous to the environment.

Immediately use barriers to contain spilled oil and follow local regulations concerning hazardous materials.

For hydraulic oil specifications see page 350.

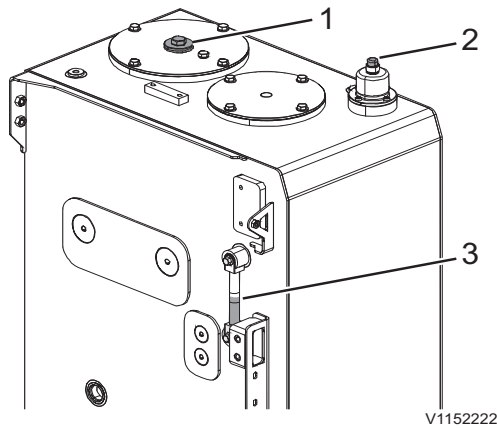

Level tube on hydraulic oil tank

- 1 Plug
- 2 Knob
- 3 Level gauge

Maintenance
Maintenance service, every 50 hours **277**

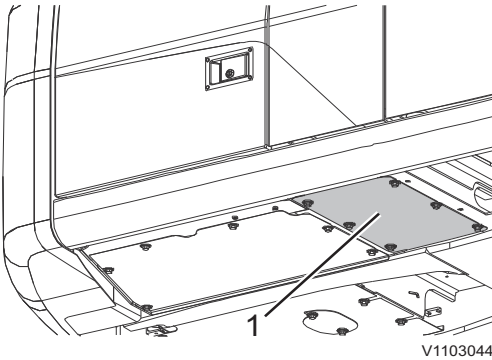

1. Cover plate

Hydraulic tank, draining

In case too much hydraulic oil was filled in it can be drained according to below procedure.

! WARNING

Risk of burns!
Hot liquids and machine parts can cause burns.
Allow the machine to cool before beginning any service.

! WARNING

Risk of burns.
Hot oil can cause severe burns to unprotected skin.
Always wear personal protective gloves, goggles and clothing when handling hot oil.

- 1 Place the superstructure crosswise the undercarriage and retract the cylinders on the boom, dipper arm and bucket and raise the stabiliser blade and stabiliser legs.
- 2 Release the hydraulic system pressure, see 221.
- 3 Turn the ignition switch to OFF position and apply the parking brake.
- 4 Turn off the electrical power with the battery disconnection switch in the cab and wait until the LED light switches off.
- 5 Remove the cover plate (1) under the hydraulic tank.
- 6 Put the end of the drain hose (2) into a container.
The drain hose (2) is provided with the machine and can be found in the tool box.
- 7 Remove the protective plug from the draining point, screw on the drain hose (2) and drain the oil.

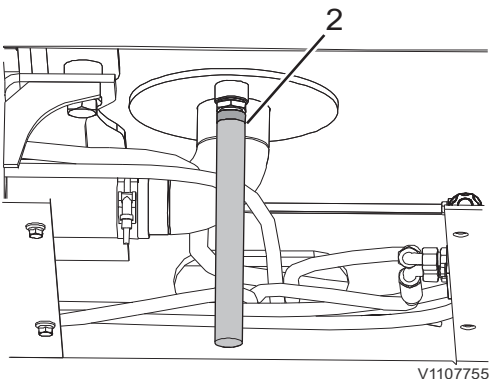

2. Drain hose

Take care of filters/oils/liquids in an environmentally safe way, see page 249.

278 Maintenance
Maintenance service, every 50 hours

Excavator unit, greasing

NOTE!

Read the safety when servicing instructions before starting any work.

Grease the points shown below every 50 hours or weekly. During the first 100 hours, the excavator unit should be greased every 10 hours or daily.

NOTE!

Under severe operating conditions where mud, water and abrasive material may enter the bearings, or after using the hydraulic hammer, the excavator unit should be greased every 10 hours or daily.

Immediately after working in water, grease the submerged parts such as the bucket pins to remove the old grease, regardless of the greasing interval.

- 1 Place the machine in service position B, see 247.
- 2 Wipe off grease nipples and grease gun to avoid dirt and sand entering the bearing.
- 3 Fill with grease until new, clean grease is forced out through the outer seals.

Arm

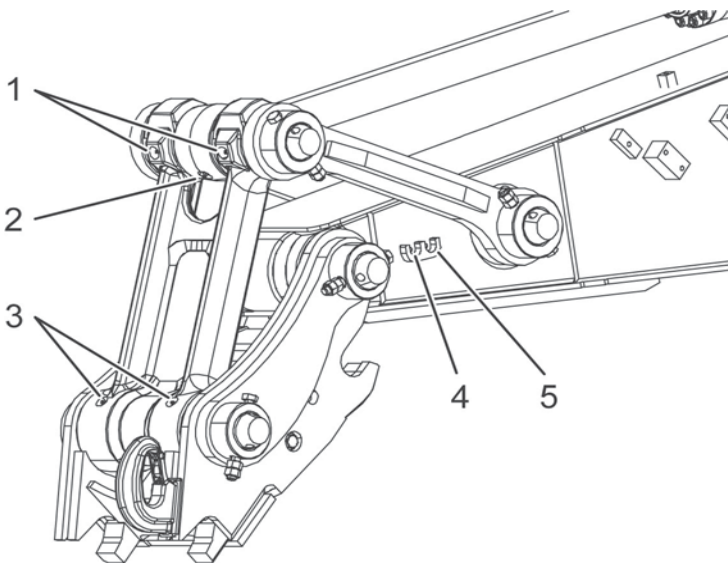

Dipper arm

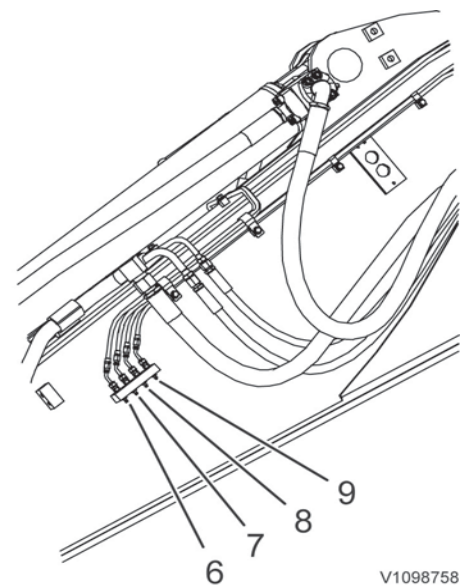

V1098758

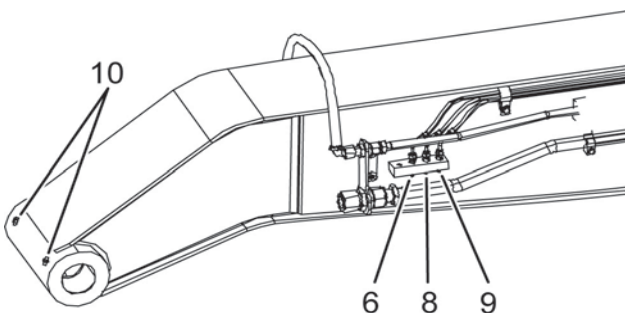

Grab arm

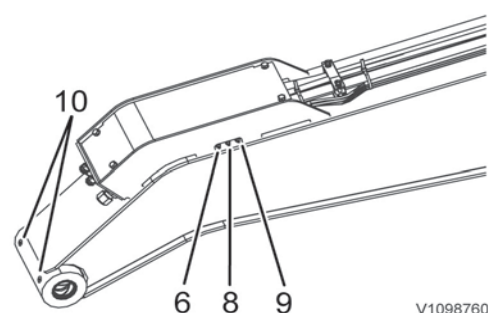

V1098760

Maintenance
Maintenance service, every 50 hours **279**

Grease points, dipper arm / grab arm (number of nipples in brackets)	
1	Bearing between lever and link (2) Depending on model the grease points can be inside of the rod
2	Bearing bucket cylinder piston rod head (1)
3	Bearing between link and quick fit (2) Depending on model the grease points can be inside of the rod
4	Bearing between dipper arm and quick fit (1)
5	Bearing between dipper arm and lever (1)
6	Dipper arm bearing to boom attachment, right hand side (1)
7	Bearing bucket cylinder foot (1)
8	Bearing dipper arm cylinder piston rod head (1)
9	Dipper arm bearing to boom attachment, left hand side (1)
10	Bearing grabber pin (2) (only grab arm)

Boom

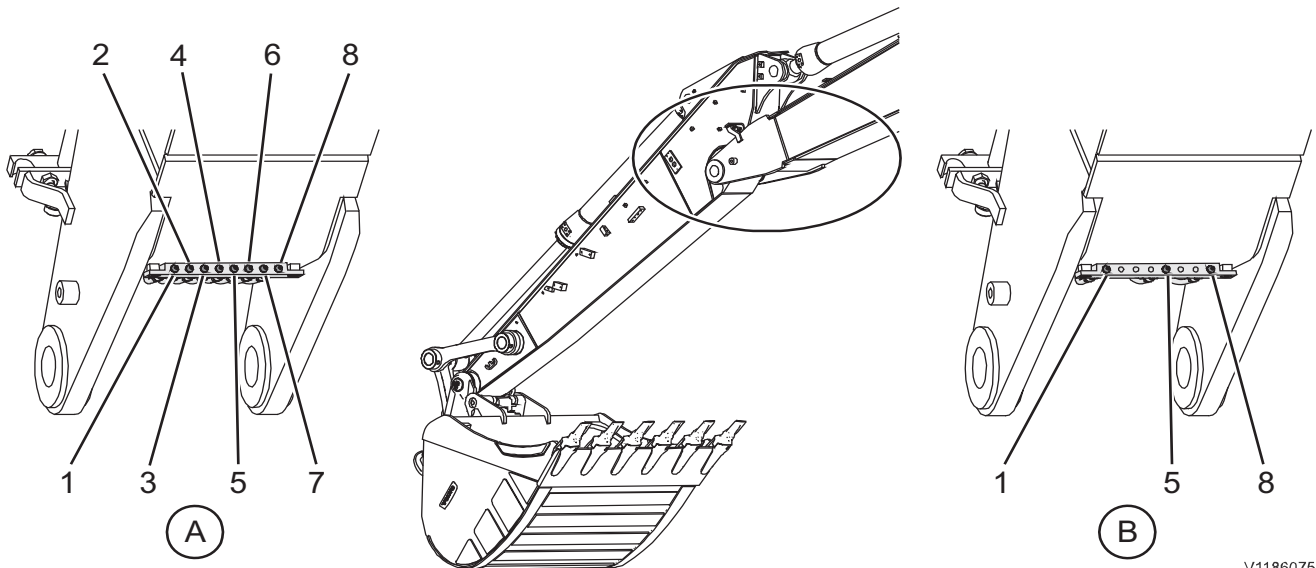

2-pcs boom (A) and mono boom (B)

V1186075

Grease points, 2-pcs boom (A) and mono boom (B)	
1	Bearing boom cylinder piston rod, left hand side
2	Bearing between 2-pcs boom 1st and 2nd part, left hand outside
3	Bearing between 2-pcs boom 1st and 2nd part, left hand inside
4	Bearing tilt cylinder piston rod head
5	Bearing dipper arm cylinder foot
6	Bearing between 2-pcs boom 1st and 2nd part, right hand inside
7	Bearing between 2-pcs boom 1st and 2nd part, right hand outside
8	Bearing boom cylinder piston rod, right hand side



Maintenance
280 Maintenance service, every 50 hours

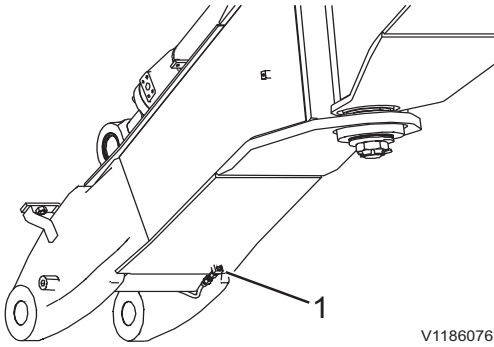

V1186076

Offset boom

Grease nipple (1) supplies the offset boom and cylinder bearings via a distributor.

Quick coupler (optional equipment)

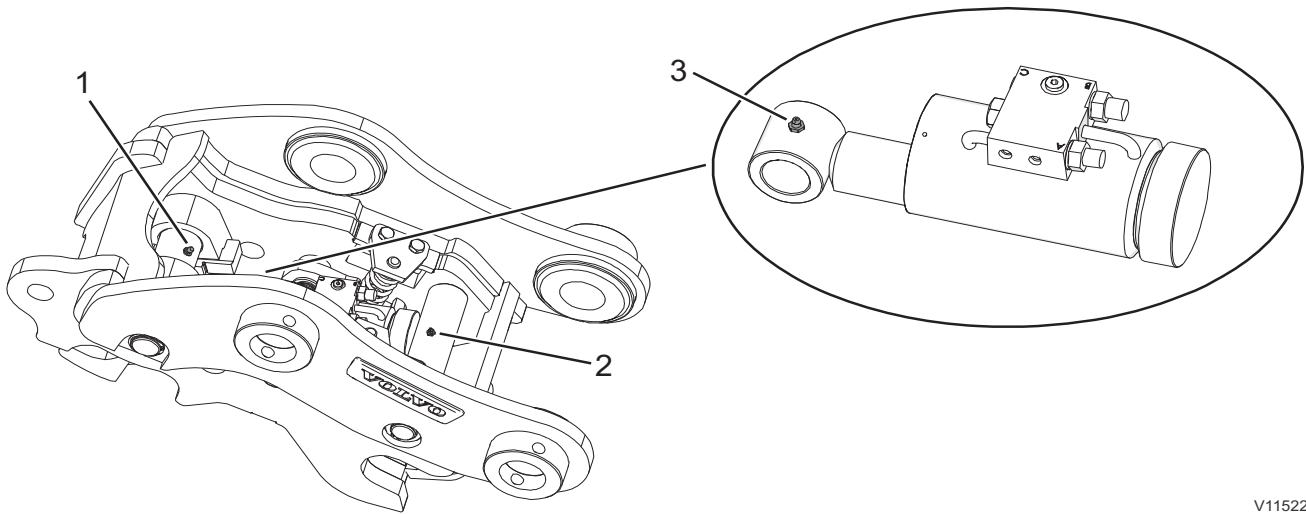

Universal attachment quick coupler — 3 grease nipples

V1152218

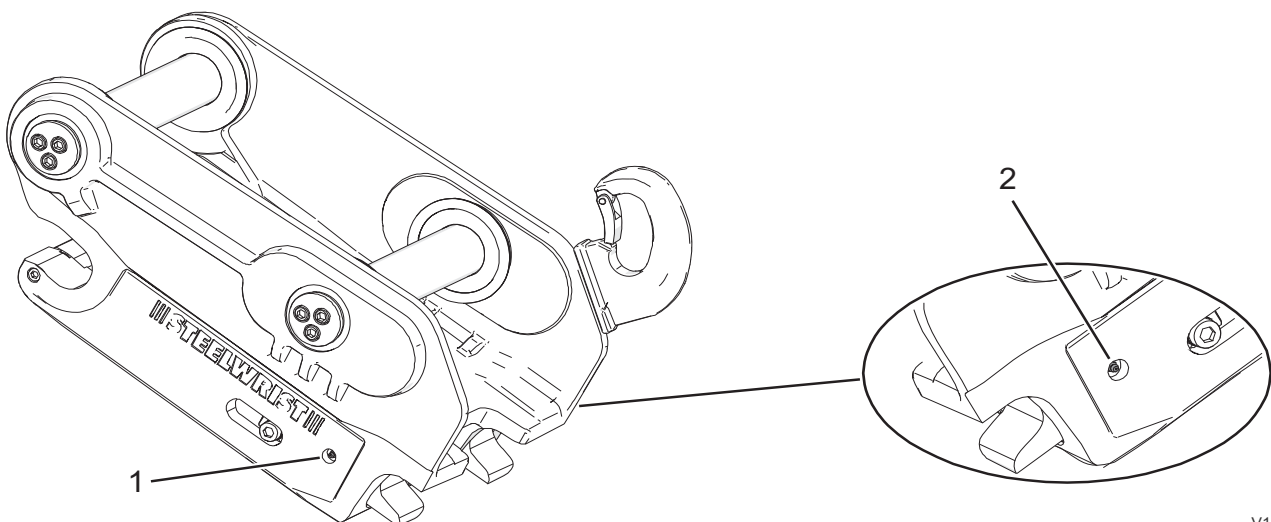

S60 quick coupler — 2 grease nipples

V1152219

Remote greasing nipples

NOTE!

Read the safety when servicing instructions before starting any work.

Grease in the nipples every 50 hours. Grease a new machine every 10 hours or daily during the first 100 hours.

NOTE!

Under severe operating conditions where mud, water and abrasive material may enter the bearings, or after using the hydraulic hammer, grease every 10 hours or daily.

Each remote grease nipple provides grease to the designated area as shown in the table.

- 1 Place the machine in service position B, see 247.
- 2 Wipe off grease nipples and grease gun to avoid that dirt and sand are entering the greasing system.
- 3 Fill with grease until new, clean grease is forced out through the outer seals.

Maintenance
282 Maintenance service, every 50 hours

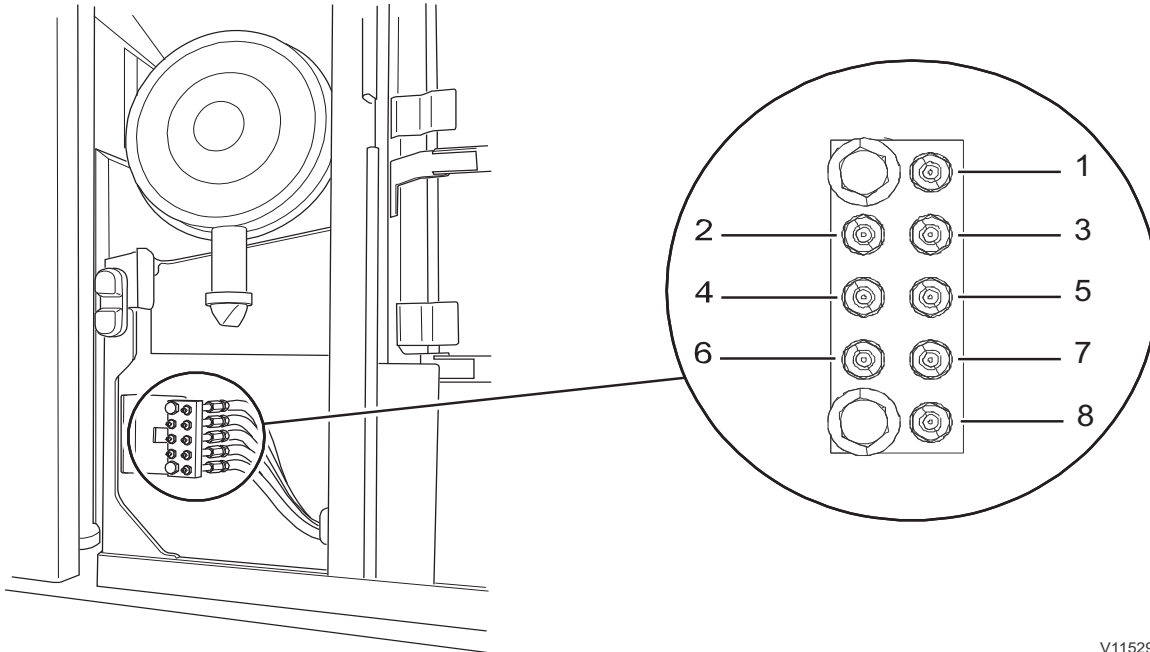

V1152970

Remote grease nipples — distribution

1	Tilt cylinder foot (only 2-piece boom)
2	Bearing boom foot left
3	Bearing boom foot right
4	Bearing left boom cylinder foot
5	Bearing right boom cylinder foot
6	Swing ring rear side
7	Swing ring front side
8	Swing gear pinion



Maintenance service, every 100 hours

Undercarriage, greasing

NOTE!

Read the safety when servicing instructions before starting any work.

Grease the undercarriage as shown below every 100 hours.

WARNING

Risk of fatal accidents by runaway machine.

Greasing the nipple for the mechanical parking brake release could cause unexpected machine movement resulting in crushing injury or death.

Never grease the grease nipple for mechanical parking brake release during machine maintenance.

NOTE!

Under severe operating conditions where mud, water and abrasive material may enter the bearings, grease every 10 hours or daily.

Immediately after working under water, grease the submerged parts such as stabiliser blade pins to remove the old grease, regardless of the greasing interval.

- 1 Place the machine in service position B, see 247.
- 2 Wipe off grease nipples and grease gun to avoid that dirt and sand not are entering the greasing system.
- 3 Fill with grease until new, clean grease is forced out through the outer seals.

Maintenance
284 Maintenance service, every 100 hours

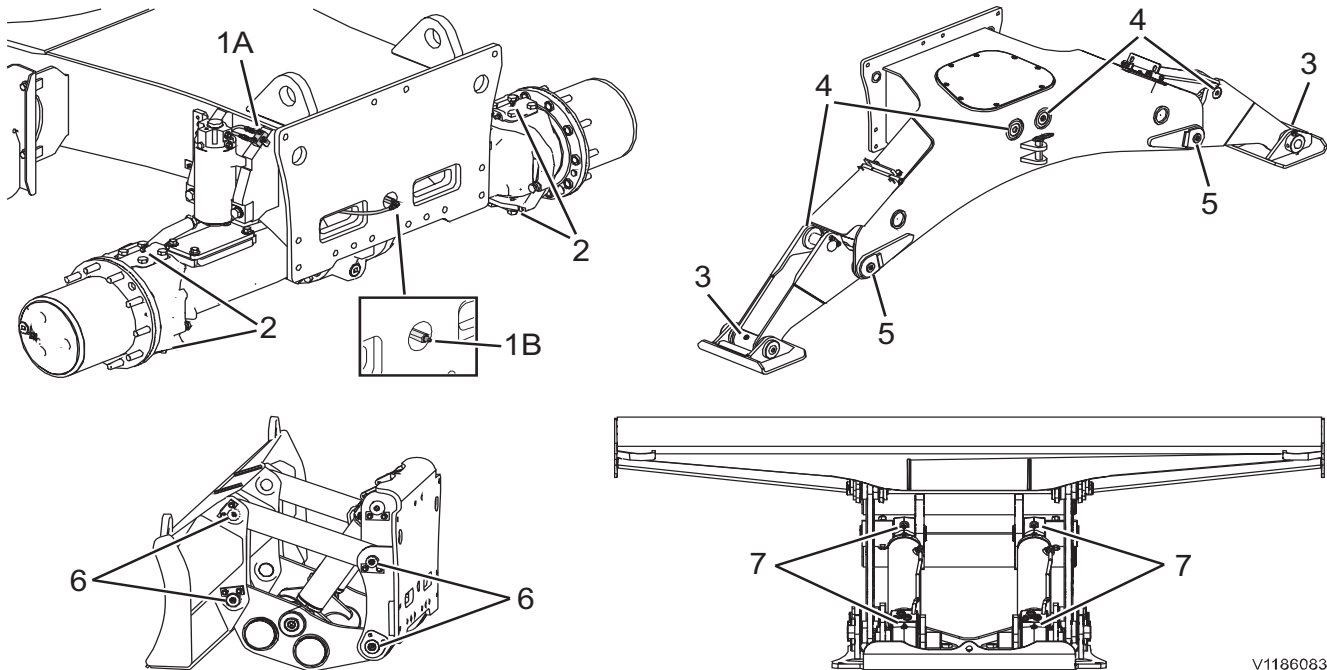

V1186083

Lubrication points(number of nipples in brackets)	
1 A	Pivot pin bearing (2) front and rear side
1 B	Pivot pin bearing (1) front side, only machine without dozer blade / outrigger in front
2	King pin bearing (2+2)
3	Stabilisers plate (2)
4	Stabilisers cylinder bearing (4) (two nipples only accessible with lowered stabilizer legs)
5	Stabilisers pins (2)
6	Dozer blade bearing left (4) and right (4)
7	Dozer blade cylinder bearing (4)

Undercarriage, greasing

Trailer towing solution (TTS) greasing

If a removable trailer towing hitch is installed on your machine as an option either on the blade or on the outrigger it must be greased regularly.

Grease the trailer hitch as shown below every 100 hours if required.

At every 500 hours inspection the trailer hitch must be checked by a qualified service technician.

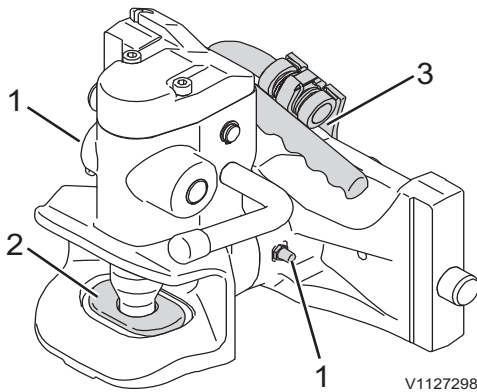

Greasing of trailer hitch for drawbar eye 40 mm

- 1 Lubrication nipple
- 2 Drawbar eye seat
- 3 Cam plate

Trailer hitch for drawbar eye 40 mm

Grease the lubrication nipples (1) and the coupling pin with the drawbar eye seat (2) in regular intervals according to the condition of use and after each cleaning with pressure washers.

NOTE!

If the trailer hitch with 40 mm drawbar eye is mounted on the outrigger, grease also the cam plate (3).

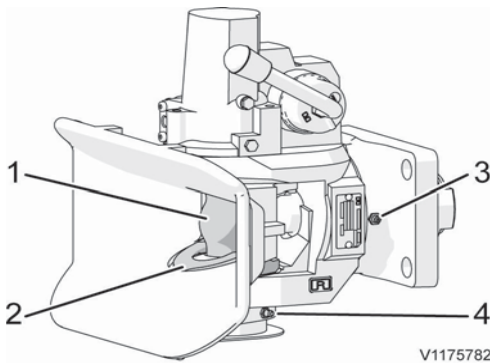

Greasing of trailer hitch for drawbar eye 50 mm
(trailer hitch for blade)

- 1 Coupling pin
- 2 Support ring
- 3 Lubrication nipple, bearing
- 4 Lubrication nipple, lower funnel bearing

Trailer hitch for drawbar eye 50 mm

Grease the coupling pin (1) with the support ring (2), the bearing (3) and the lower funnel bearing (4) in regular intervals according to the condition of use and after each cleaning with pressure washers.

Maintenance
286 Maintenance service, every 100 hours

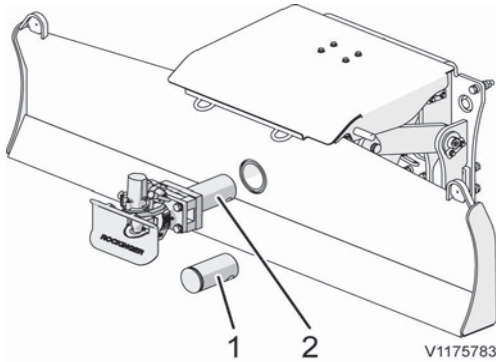

Greasing of trailer hitch bolt or plug for blade
1 Plug bolt
2 Trailer hitch bolt

Greasing of trailer hitch bolt or plug for blade and on blade

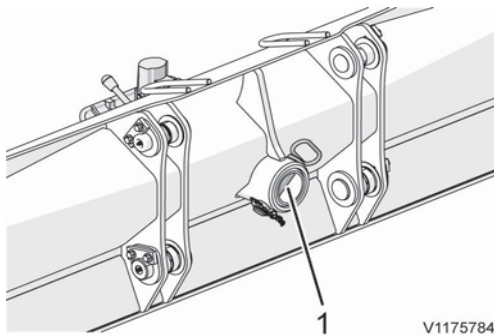

Greasing of trailer hitch fixation bolt on blade
1 Fixation bolt

If the trailer hitch is mounted on the blade, grease the trailer hitch bolt (2) or the plug bolt (1).

Grease the fixation bolt (1).

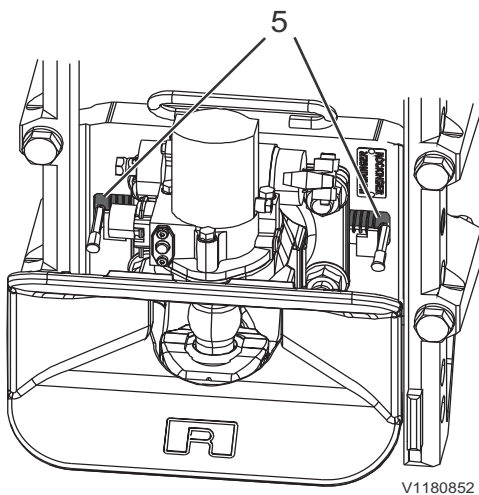

Greasing of trailer hitch for drawbar eye 50 mm
(only on trailer hitch for outrigger)
5. Locking bolts

Greasing after cleaning with pressure washer

If the trailer hitch with 50 mm drawbar eye is mounted on the outrigger, grease also the locking bolts (5) on both sides after each cleaning with a pressure washer.

Maintenance

The regularly inspection for wear on the towing hitch must be performed by a qualified service technician every 500 hours.

Maintenance service, every 250 hours

Engine oil level, checking

Check the engine oil level every 250 hours with the engine oil dipstick.

NOTE!

Check the engine oil level daily on the IC (Instrument Cluster) with the machine on level ground before start working with the machine.

If the message 'Engine oil level low' appears on the IC (Instrument Cluster), place the machine on level ground, turn off the engine and check the engine oil level with the dipstick according to below procedure.

If a difference appears between the engine oil dipstick and the value shown in the IC (Instrument Cluster), the dipstick value is always reliable.

NOTE!

Read the safety when servicing instructions before starting any work.

WARNING

Risk of serious injury.
Rotating parts could cause serious cutting or crushing injury.
Never open the engine hood when the engine is running.

WARNING

Risk of burns!
Hot liquids and machine parts can cause burns.
Allow the machine to cool before beginning any service.

Level checking

- 1 Place the machine on level ground in service position B, see page 247.
- 2 Climb the machine by using the handholds and the indicated footsteps.
- 3 Open the engine hood.
- 4 Pull out oil dipstick (A) and wipe it with a clean cloth.
- 5 Push the dipstick in and pull it out again.
- 6 If the oil level is within the marked area (between C and D) on the dipstick it is normal. If the oil level is low, top up (B).
Use only the allowed oil quality grades and the correct oil viscosity for the ambient air temperature, see page *Engine oil*.

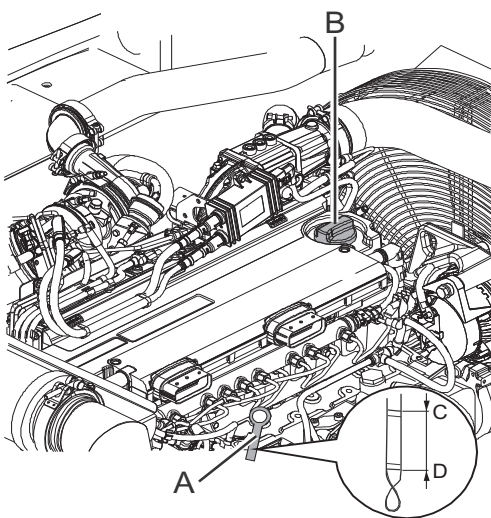

V1104627

Engine oil, draining

In case too much engine oil was filled in it should be drained according to below procedure.

288 Maintenance
Maintenance service, every 250 hours

! WARNING

Risk of burns!
Hot liquids and machine parts can cause burns.
Allow the machine to cool before beginning any service.

! WARNING

Risk of burns.
Hot oil can cause severe burns to unprotected skin.
Always wear personal protective gloves, goggles and clothing when handling hot oil.

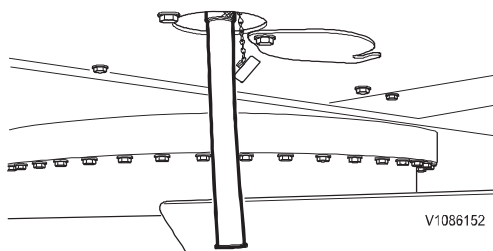

Engine oil draining

- 1 Place the machine in service position B, see page 247.
- 2 Loosen the left nut on the cover and swing the cover to the side.
- 3 Put the end of the drain hose into a suitable container.
- 4 Remove the protection cap and screw the drain hose onto the drain plug.
The drain hose is provided with the machine and can be found in the tool box.
- 5 After the oil is drained, remove the hose and install the protecting cap.

Take care of filters/oils/liquids in an environmentally safe way, see page 249.

Coolant level, checking

Check the coolant level every 250 hours.

The cooling system is filled with Volvo Coolant VCS, which fulfils the highest requirements regarding freeze-, corrosion-, and cavitation protection. To avoid damage to the engine, it is very important that Volvo Coolant VCS is used when topping up coolant.

Volvo Coolant VCS is yellow and a decal by the filling point shows that the system is filled with this coolant (see picture).



V1066019

Volvo Coolant VCS decal

NOTICE

Risk of machine damage.
Mixing different coolants and corrosion preventives could damage the engine.
Use only Volvo Coolant VCS when filling the coolant system.

NOTE!

Read the safety when servicing instructions before starting any work.

Maintenance
Maintenance service, every 250 hours 289

! WARNING

Risk of scalding and severe burns to unprotected skin. High-pressurised hot coolant may rush out of expansion tank and cause severe burns. Before removing the expansion tank pressure cap:

- Shut down the engine.
- Allow the engine to cool
- Turn the pressure cap slowly to release any pressure.

- 1 Place the machine on level ground in service position B, see page 247.
- 2 Climb the machine by using the handholds and the indicated footsteps.
- 3 Open the engine hood.

- 4 **NOTE!**
The coolant level should be checked after the engine has been run until warm and then cooled down.

Check the coolant level in the expansion tank. The level should be between the MAX and MIN marks on the expansion tank.

- 5 **NOTE!**
Coolant shall always be filled through the filling cap (1). Do not fill the coolant through the pressure cap (3) in the expansion chamber.

In case of low level, remove the filling cap (1) and top up until the level is in the middle between MIN. and MAX. For coolant specifications see page 331.

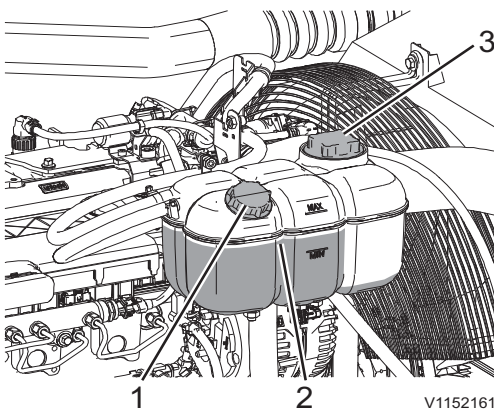

Expansion tank

- 1 Filling cap
- 2 Coolant level
- 3 Pressure cap

Coolant, draining

In case too much coolant was filled in it can be drained according to below procedure.

Maintenance
290 Maintenance service, every 250 hours

! WARNING

Risk of scalding and severe burns to unprotected skin. High-pressurised hot coolant may rush out of expansion tank and cause severe burns. Before removing the expansion tank pressure cap:

- Shut down the engine.
- Allow the engine to cool
- Turn the pressure cap slowly to release any pressure.

- 1 Place the machine in service position F, see page 247.
- 2 Climb the machine by using the handholds and the indicated footsteps.
- 3 Open the engine hood and remove the filling cap (1) and the pressure cap (3).
- 4 Climb down the machine and remove the cover (4) under the radiator.
- 5 Open the left side door and remove the drain valve cap (5).

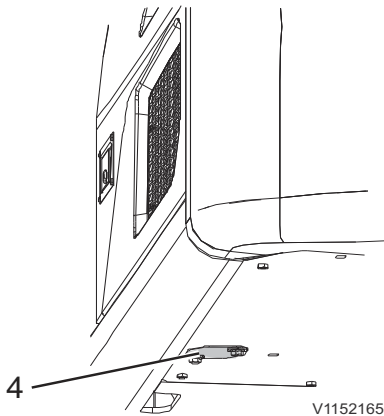

4. Cover under radiator

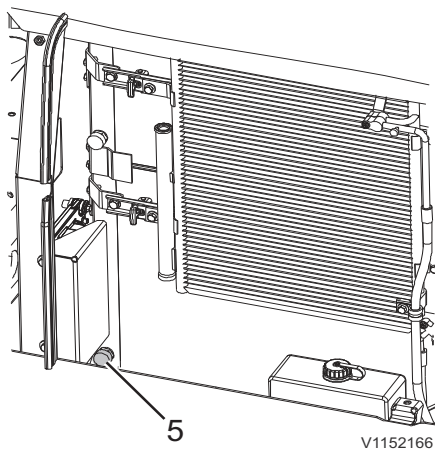

5. Coolant draining point

- 6 Attach the drain hose provided as a service tool with the machine.
- 7 Drain only the overfilled amount of coolant into a suitable container.
- 8 Remove the drain hose and reinstall the plug (5) and the cover (4).
- 9 Check the coolant level again after the draining procedure.

Take care of filters/oils/liquids in an environmentally safe way, see page 249.

Swing drive unit, checking oil level

Check the oil level every 250 hours (EW180E only).

NOTE!

Read the safety when servicing instructions before starting any work.

WARNING

Risk of burns.

Hot oil can cause severe burns to unprotected skin.

Always wear personal protective gloves, goggles and clothing when handling hot oil.

NOTICE

Always clean around the oil dipstick before you check the oil level. Dirt in the oil damages the swing gearbox.

NOTE!

It is very important that the oil level is always correct and that it is checked at working temperature.

Too little oil may lead to insufficient lubrication of the swing drive unit and cause costly damage.

Too much oil may lead to oil foaming, and cause the swing drive unit to overheat.

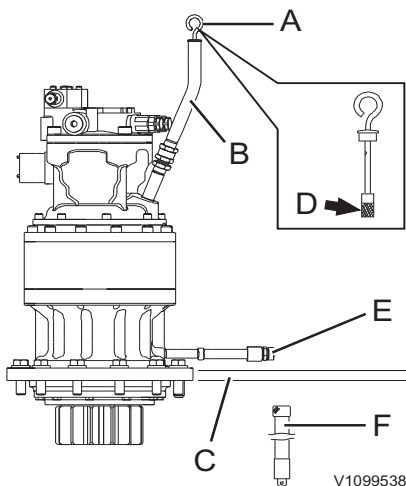

- 1 Place the machine in service position B, see page 247.
- 2 Pull out oil dipstick (A) and wipe it with a clean cloth.
- 3 Insert oil dipstick and pull it out again.
- 4 Check the oil level. If the level is in the center of "D", the level is correct.
- 5 If the level is low, top up oil through oil filler hole (B) to correct level.
- 6 If the level is high,
 - Place the machine in service position F, see page 247.
 - Remove the under cover (C).
 - Place a suitable sized container under the drain valve (E).
 - Open the protection cap of drain valve (E).
 - Attach the drain hose (F) and drain the oil to the correct level.
 - Disconnect the drain hose.
 - Close the protecting cap.
 - Reinstall the under cover (C).

For oil specification, see page 327.

Maintenance 292 Maintenance service, every 250 hours

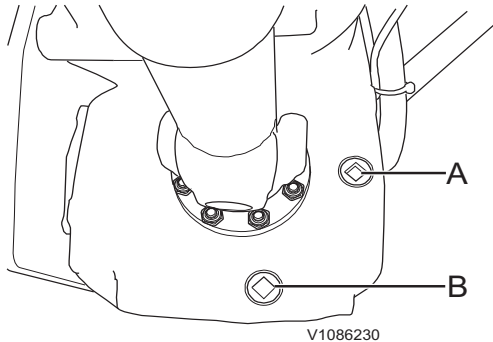

A Oil level plug
B Drain plug

Travel gearbox oil level, checking

The travel gearbox is positioned under the machine. Be observant for sign of leakage during the daily inspection.

Check the travel gearbox oil level every 250 hours.

NOTE!

Read the safety when servicing instructions before starting any work.

- 1 Remove oil level plug (A) and check that the oil is up to the lower edge of the hole.
- 2 If the level is too low, fill new oil through the hole for the oil level plug (A) until the level is up to the lower edge of the hole.
- 3 Reinstall the oil level plug after the oil level check.

Take care of filters/oils/liquids in an environmentally safe way, see page 249.

Axes, checking oil level

NOTE!

Read the safety when servicing instructions before starting any work.

Axes, checking oil level

Check the oil level on both axles every 250 hours.

- 1 Park the machine on a level and stable surface, activate the travel brake and block the wheels.
- 2 Clean the oil level plugs before removing them.
- 3 Remove the plugs (A) and (B) and check that the oil level is up to the lower edge of the hole, fill up if necessary.
- 4 Reinstall the oil level plugs with tightening torque 50 Nm (37 lbf ft).

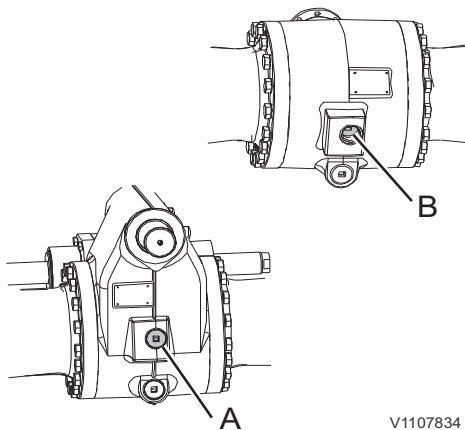

A Front axle, oil level plug
B Rear axle, oil level plug

Axle hubs, checking oil level

Check the oil level on axle hubs every 250 hours.

- 1 Park the machine on a level and stable surface.
- 2 Lift up the machine by using the stabiliser legs or blade.

NOTE!

If the machine is not equipped with stabilizers, lift up the wheels using the digging equipment.

- 3 Secure the machine with appropriate jack stands (1) (load capacity min. 8000 kg, 17650 lb for each) under the axles!
- 4 Place the oil drain/filler plug (1:a) to topmost position (12 o'clock) as shown on the illustration and carefully remove the plug.
- 5 Turn the wheel until the drain hole (1:b) is at 9 o'clock position as shown on the illustration.

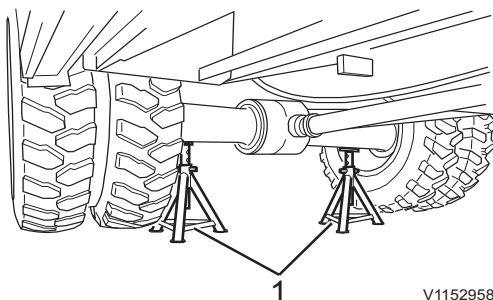

Axle on jack stands (1)

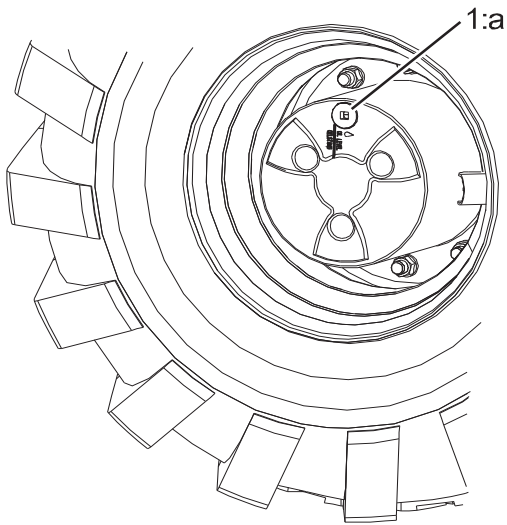

Planetary carrier positions

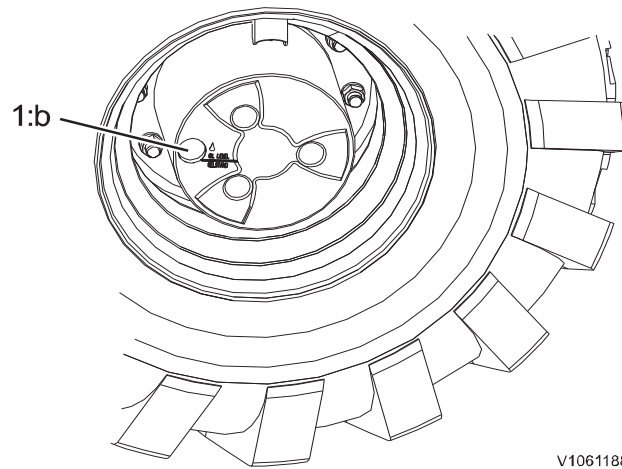

V1061188

- 6 Check that the oil level is up to the lower edge of the hole, fill up if necessary.
- 7 Reinstall the oil level plugs with tightening torque 50 Nm (37 lbf ft).

294 Maintenance
Maintenance service, every 250 hours

Cab prefilter, cleaning and replacing

Clean the cab prefilter every 250 hours and replace it every 2000 hours.

Dusty or contaminated air requires more frequent cleaning and replacements of the prefilter. For the best climate in the cab, clean and replace the prefilter regularly.

NOTE!

Read the safety when servicing instructions before starting any work.

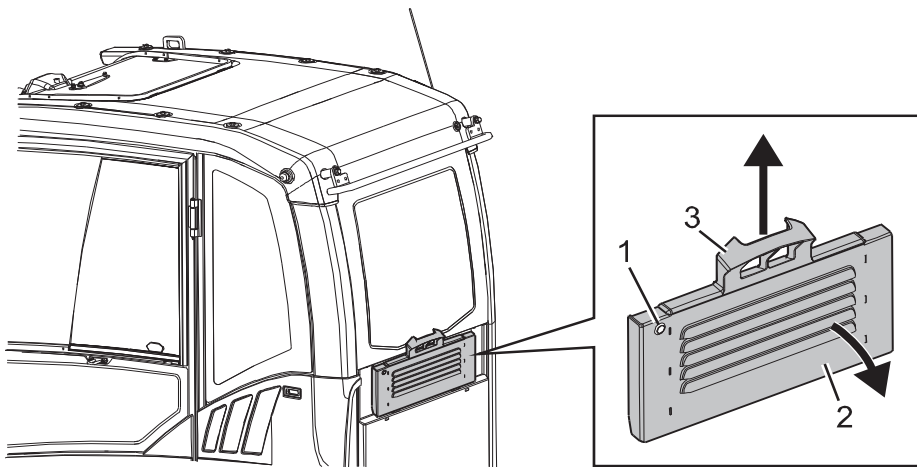

V1059865

- 1. Locking device
- 2. Hatch
- 3. Carrier

! WARNING

Risk of hazardous inhalation.

Dangerous dust can lead to serious health problems.

Always wear personal protective equipment, including filter mask, eye protection and appropriate gloves when handling and cleaning the engine compartment, coolers and air filters.

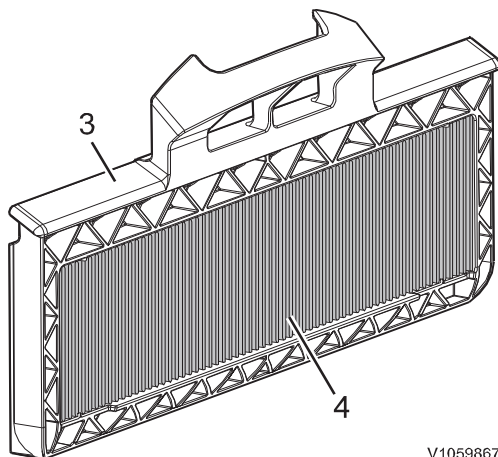

V1059867

- 3. Carrier
- 4. Cab prefilter

- 1 Open the locking device (1) and pull out the hatch (2).
- 2 Pull out the carrier (3) and remove the cab prefilter (4).
- 3 Clean the cab prefilter (4) with compressed air.

NOTE!

When using compressed air, keep the nozzle at a distance from the fins to prevent damage. Clean the filter with compressed air with a maximum pressure of 2 bar (29 psi).

- 4 If the cab prefilter (4) is damaged or heavily contaminated, replace it with a new one.
- 5 Install the cleaned cab prefilter (4) and assemble in reverse order.

Take care of filters/oils/liquids in an environmentally safe way, see page 249.

Maintenance service, every 500 hours

Cab door hinges, greasing

Grease the cab door hinges (1) every 500 hours.

For the correct grease specifications, see page 327.

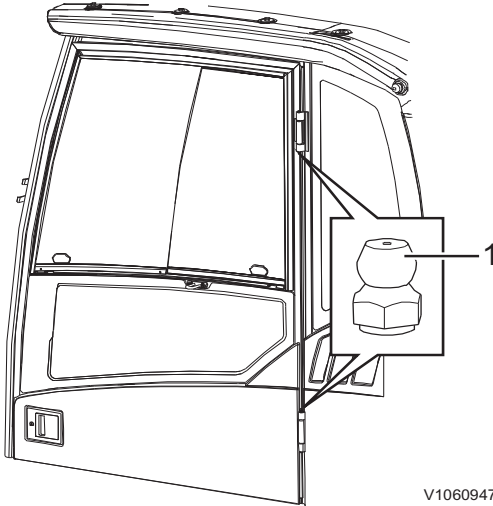

V1060947

1. Cab door hinges

Battery electrolyte level, check

Check the battery electrolyte level every 500 hours.

NOTE!

Read the safety when servicing instructions before starting any work.

WARNING

Risk of chemical burns.

Contact with battery acid causes serious chemical burns.

Always wear personal protective gloves, goggles and clothing when handling batteries.

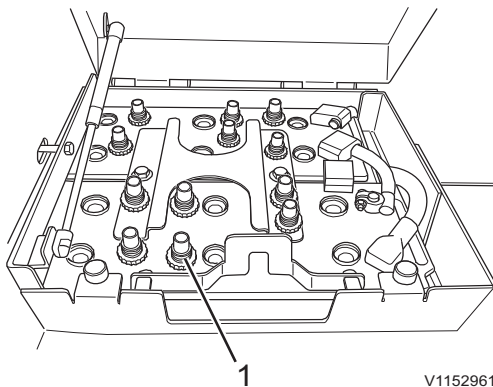

V1152961

1. Cell caps

- 1 Place the machine in service position C, see page 247.
- 2 Turn the ignition switch to OFF position.
- 3 Turn off the electrical power with the battery disconnection switch in the cab and wait until the LED light switches off.
- 4 Open the battery cover.
- 5 Remove all cell caps.

296 Maintenance
Maintenance service, every 500 hours

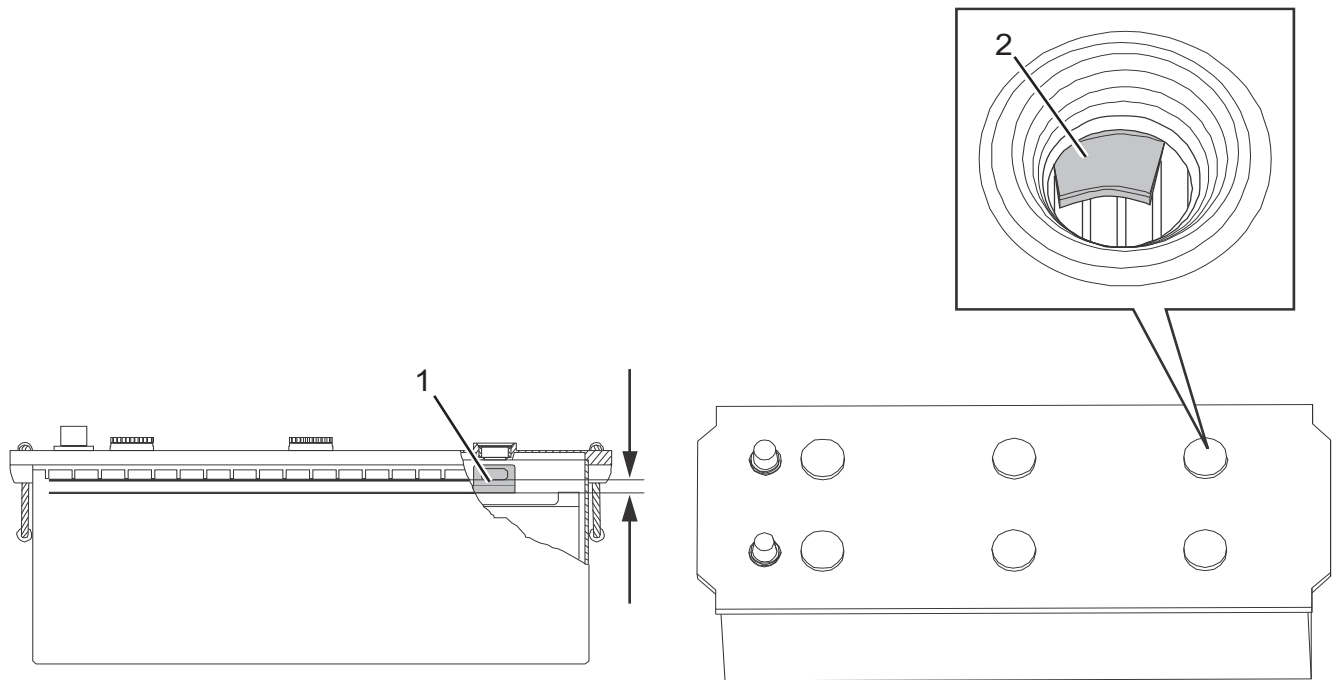

V1100964

Electrolyte level

- 1 Level
- 2 Level indicator

- 6 Check the electrolyte level (1). Fill in distilled water up to the level indicator (2).
- 7 Check that the cable terminals and battery terminals are clean, well tightened and coated with acid free dielectric grease.
- 8 Reinstall the caps and close the battery cover.
- 9 Operate the machine after topping up, so that the water is mixed up with the battery electrolyte.
This is even more important in cold weather.

Cab main filter, cleaning

NOTE!

If the cab is equipped with a HEPA filter (optional, see information on decal on air conditioning unit), it must be replaced every 500 hours (workshop job). It must not be cleaned.

Clean the standard main filter every 500 hours and replace it every 2000 hours.

NOTE!

Read the safety when servicing instructions before starting any work.

The filter is located behind the seat under the electrical distribution box.

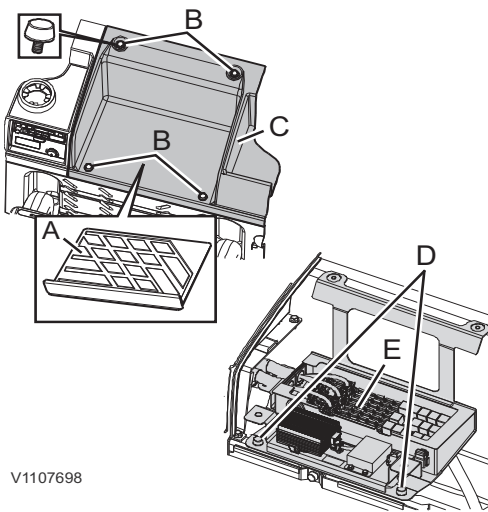

V1107698

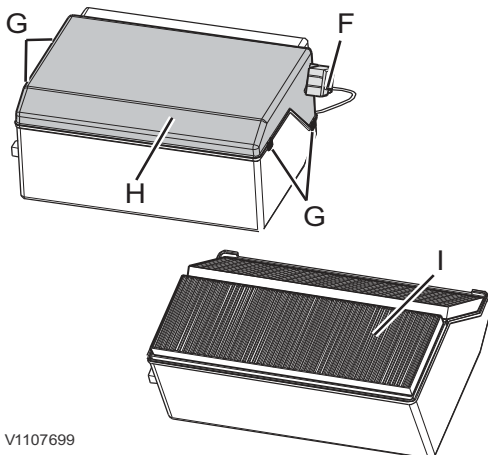

V1107699

WARNING

Risk of hazardous inhalation.

Dangerous dust can lead to serious health problems.

Always wear personal protective equipment, including filter mask, eye protection and appropriate gloves when handling and cleaning the engine compartment, coolers and air filters.

- 1 Turn the ignition switch to OFF position.
- 2 Turn off the electrical power with the battery disconnection switch in the cab and wait until the LED light switches off.
- 3 Move the operator's seat to the front position, and fold the backrest forward.
- 4 Remove the rubber mat (A).
- 5 Unscrew the bolts (B) and remove the plastic case (C).
- 6 Remove the bolts (D) from the electrical distribution box.
- 7 Put aside the complete electrical distribution box (E).
- 8 Disconnect the wire harness (F).
- 9 Open the latches (G) and remove the cover (H).
- 10 Clean the filter (I) with compressed air.

NOTE!

When using compressed air, keep the nozzle at a distance from the fins to prevent damage. Clean the filter with compressed air with a maximum pressure of 2 bar (29 psi)

11 If the filter is damaged or heavily contaminated, replace it with a new one.

12 Install the cleaned filter in the reverse order.

Take care of filters/oils/liquids in an environmentally safe way, see page 249.

Intercooler, radiator, hydraulic oil cooler, cleaning

Clean the intercooler, the radiator and the oil cooler every 500 hours. When working in dusty or dirty environment, it may be necessary to clean it more often.

NOTE!

Read the safety when servicing instructions before starting any work.

! WARNING

Risk of hazardous inhalation.

Dangerous dust can lead to serious health problems.

Always wear personal protective equipment, including filter mask, eye protection and appropriate gloves when handling and cleaning the engine compartment, coolers and air filters.

! WARNING

Risk of serious injury.

Compressed air, water jets or steam may cause damage to unprotected skin and eyes.

Always wear personal protective gloves, goggles and clothing when using compressed air, water jets or steam.

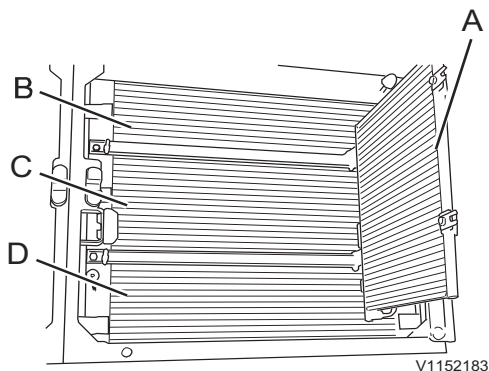

- A Condenser
- B Intercooler
- C Hydraulic oil cooler
- D Radiator

- 1 Place the machine in service position C, see page 247.
- 2 Turn the ignition switch to OFF position and turn off the electrical power with the battery disconnection switch.
- 3 Climb the machine by using the handholds and the indicated footsteps and open the engine hood.
- 4 Climb down the machine and open the left side door.
- 5 Pull out the radiator net and clean it.
- 6 Swing out the condenser (A) by pulling the straps to the left side.
- 7 Clean the intercooler (B), hydraulic oil cooler (C) and radiator (D) outside with compressed air flow or steam.

NOTICE

When using compressed air, keep the nozzle at a distance from the fins to prevent damage. Damaged fins may cause leakage or overheating.

NOTE!

If there is a large amount of contamination on the fins, apply detergent, thoroughly clean and rinse with tap water.

- 8 Reinstall everything again afterwards and close the side door and the engine hood.

Attachment quick coupler

(optional equipment)

Check and adjust the set screw on the universal attachment quick coupler every 500 hours according to below procedure.

Maintenance
Maintenance service, every 500 hours **299**

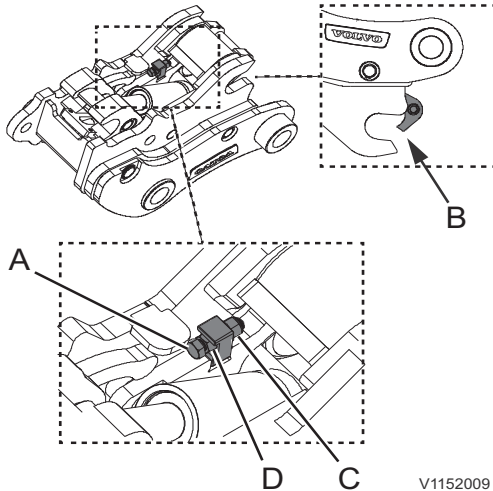

- A Adjustment screw
- B Front pin lock (75% opening)
- C Lock nut
- D Tightening nut

Besides the greasing (see page 278), the universal attachment quick coupler has also another maintenance interval which is the adjustment of the set screw.

NOTE!

Read the safety when servicing instructions before starting any work.

- 1 Disconnect the attachment from the universal attachment quick coupler.
- 2 Curl the attachment quick coupler in towards the dipper arm.
- 3 Turn off the machine and move the control lockout lever down.
- 4 Adjust the set screw (A) so that the front pin lock will open for approximately 75% of the bucket pin diameter (B).
- 5 Tighten the lock nut (C) and the tightening nut (D) with a tightening torque of 240 Nm (177 lbf ft).
- 6 Check the functionality of the universal attachment quick coupler in a safe environment after the adjustment of the set screw.



Maintenance service, every 1000 hours

Wheel nuts, checking tightening

Check the tightening torque of the wheel nuts every 1000 hours.

After having changed a tyre or if the wheel has been removed and installed for any other reason, the wheel nuts must be check-tightened after 2 hours of operation or 50 km of travelling.

Tightening torques see page 347.

Tighten the wheel nuts crosswise in steps up to the specified torque. Replace sluggish or slightly corroded wheel nuts and bolts!

Friction-reducing thread lubrications are not permitted (in particular lubricants with Cu, MoS₂ additives or GL5-oil).

Overload warning

Check the overload warning system every 1000 hours according to below procedure.

- 1 Place the machine on level and firm ground.
- 2 Select W-mode on the mode selector and engage the overload warning with the button on the keypad, see page 80.
- 3 Operate the boom cylinders to their upper end positions. The overload warning signal should sound and the overload symbol should appear in the IC (Instrument Cluster). If not contact a qualified service technician.

Maintenance service, every 2000 hours

Coolant

NOTICE

If the warning of high coolant temperature is shown on the display unit, the engine must be stopped immediately.

Check the coolant contents (%) every 2000 hours or every 1 year.

The cooling system is filled with Volvo Coolant VCS, which fulfils the highest requirements regarding freeze-, corrosion-, and cavitation protection. To avoid damage to the engine, it is very important that Volvo Coolant VCS is used when filling or changing the coolant.

Volvo Coolant VCS is yellow and a decal by the filling point shows that the system is filled with this coolant (see picture).



V1066019

NOTICE

Volvo Coolant VCS must never be mixed with any other coolant or corrosion protection to avoid damage to the engine.

The cooling system capacity when changing, see page *Lubricants and fluids, capacities (litres)*.

If concentrated Volvo Coolant VCS and clean water (see page 331) is used, the table below shows the approximate amount of concentrated coolant needed for freezing protection. The content of Volvo Coolant VCS must never be less than 40% of the total mixture.

If in doubt of the water's quality, use the ready-mixed Volvo Coolant VCS, which contains 40% concentrated coolant.

NOTICE

In order to avoid damage to engine and cooling system, different brands of coolant or corrosion protection must not be mixed.

Freeze protection down to	Content of concentrated coolant
-25 °C (-13 °F)	40%
-35 °C (-31 °F)	50%
-46 °C (-51 °F)	60%

Maintenance
302 Maintenance service, when required

Maintenance service, when required

Fuel, filling

! WARNING

Risk of fire and explosion.

A running auxiliary heater during fuel filling could cause fire and explosion.

Switch off the auxiliary heater before filling fuel.

If the machine is laid up for a longer period, the tank ought to be completely full with fuel to prevent corrosion of the insides of the tank.

NOTE!

Do not fill any other liquids than fuel in the fuel tank!

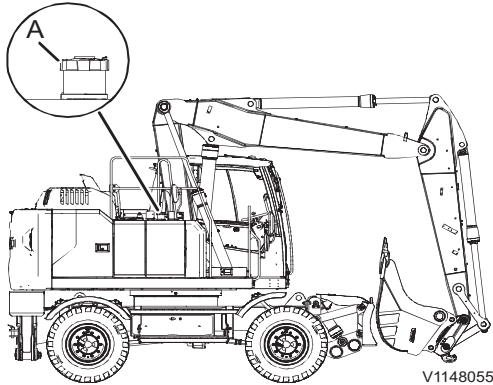

A. Fuel filler cap

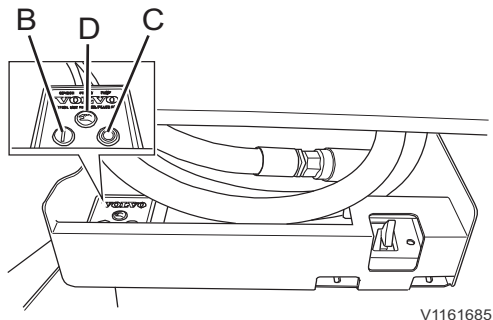

Fuel filling pump

- B. Green button, start
- C. Red button, stop
- D. Manual filling button

Manual fuel filling

- 1 Clean the area around fuel filler cap (A).
- 2 Open the filler cap and fill fuel.

Fuel filling with built-in pump

Fuel filling can also be done with an electrical pump under the fuel tank, which is provided with an electronic overfilling protection. The inlet side of the pump is connected to a suction pipe via a hose. At the outer end of the pipe there is an inlet strainer.

- 1 Fold down the cover under the fuel tank.
- 2 Put the hose in the fuel barrel.
- 3 Start the pump by pressing green button (B).
When the tank is full, the pump stops automatically.
- 4 If you would like to interrupt the filling, press red button (C).
- 5 When filling is done with the manual filling button (D) the button must be pressed the whole time.
The pump will stop when releasing the button.

NOTE!

When using the manual filling button (D) the pump will not stop automatically when the tank is full.

Fuel tank capacity: see specifications chapter

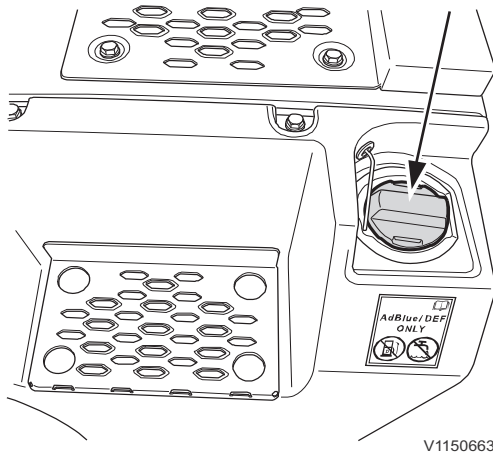

AdBlue®/DEF tank cap

AdBlue®/DEF, filling

NOTICE

Risk of machine damage.

Refilling fluids with anything other than what is specified in this manual could cause permanent damage to the catalyst system. Only refill fluids with those specified in this procedure.

NOTICE

Risk of machine damage.

AdBlue®/DEF is highly corrosive. If the tank is overfilled, AdBlue®/DEF may leak out through the air vent pipe. If the tank is overfilled and the fluid in it freezes, the tank and hoses can be permanently damaged.

Do not overfill the tank. Always stop filling when the fluid level reaches the filling port or when an automatic filling nozzle shuts off.

NOTE!

Do not fill with any fluid other than that specified in ISO 22241-1. We recommend that you do not reuse drained AdBlue®/DEF due to the risk of contamination.

AdBlue®/DEF tank capacity, see page 338.

NOTE!

Be careful not to overfill AdBlue®/DEF more than the tank capacity, otherwise it could overflow from the air breather line of the tank.

AdBlue®/DEF quality, see page 336.

If the AdBlue®/DEF level is low, an alarm indication is displayed. Fill the AdBlue®/DEF tank with AdBlue®/DEF.

- AdBlue®/DEF is not classified as a hazardous substance but should still be handled with care. It is highly corrosive.
- If it comes into contact with the skin, rinse well with water.
- If it comes into contact with the eyes, rinse thoroughly for several minutes. Consult a doctor if necessary.
- If inhaled, breathe fresh air and contact a doctor if necessary.
- If swallowed, drink water and contact a doctor.
- Do not allow AdBlue®/DEF to come into contact with other chemicals.
- AdBlue®/DEF is not combustible. If AdBlue®/DEF is exposed to high temperatures it will decompose into ammonia and carbon dioxide.
- AdBlue®/DEF must not be mixed into the diesel tank and diesel must not be mixed into the AdBlue®/DEF tank.

NOTE!

AdBlue®/DEF filling equipment must be designed for a maximum filling rate of 40 litres/minute, and adjustable to a rate below 40 litres/minute. If filling problems occur and remain after the filling filter has been cleaned, please refer to the manual for the filling equipment and take the necessary action.

For distribution of AdBlue®/DEF (only valid for US market):

- Volvo CE Customer Support: 1-877-823-1111 (business hours)
- www.volvoce.com (outside business hours)

For distribution of AdBlue®/DEF (all other markets), please contact your local Volvo dealer for more information.

304 Maintenance Maintenance service, when required

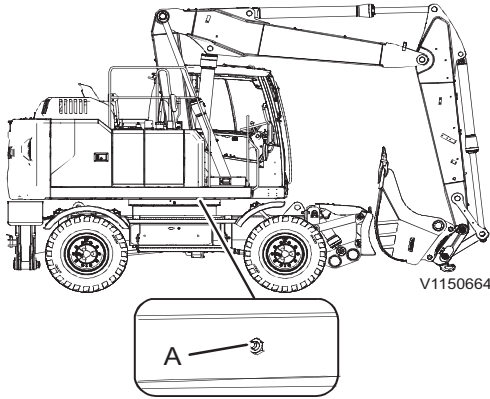

A Drain plug

AdBlue®/DEF tank, draining

NOTE!

Read the safety when servicing instructions before starting any work.

- 1 Park the machine on a level ground and move the superstructure as shown in the figure.
- 2 Lower the bucket to the ground.
- 3 Turn the ignition switch to stop position.
- 4 Move the control lockout lever down to lock the system securely. See page 110.
- 5 Remove drain plug (A) using a L wrench from the tank.
- 6 Drain AdBlue®/DEF into a container.

NOTICE

Take care of filters, oils and liquids in an environmentally safe way.

- 7 Install the drain plug to the tank.

Water separator, draining

Drain the water separator if the control lamp lights up on the IC (Instrument Cluster) or when required.

NOTE!

Read the safety when servicing instructions before starting any work.

- 1 Place the machine on level ground and turn the ignition switch to OFF position and apply the parking brake.
- 2 Check for water and the sediment in the water separator bowl (A).
- 3 Place a suitable sized container under drain hose (B).
- 4 Open the drain valve (C) and drain the water and sediment if needed.
- 5 Close the drain valve (C).
- 6 Bleed the fuel system, see page 304.

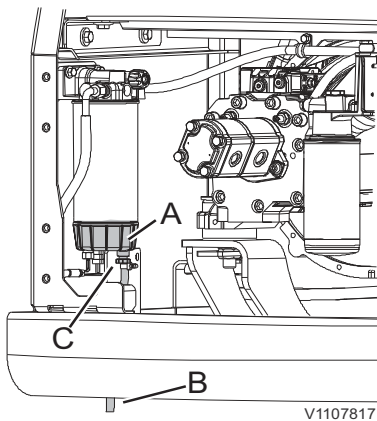

Water separator

- A Water separator bowl
- B Drain hose
- C Drain valve

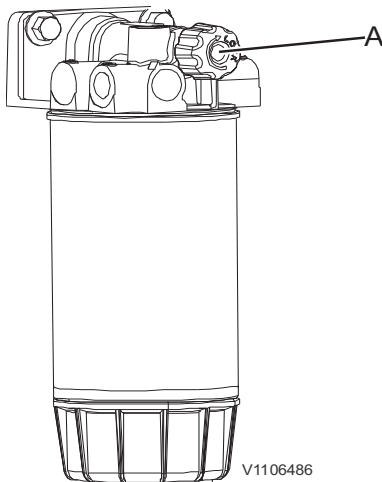

A - pump knob

Fuel system, bleeding

Air must be bled out of the fuel injection system whenever the machine runs out of fuel while the engine is running.

NOTICE

Do not attempt to start the engine under any circumstances until the air in the system has been bled out completely, otherwise the injection pump can be seriously damaged.

- 1 Turn off the main electric power with the battery disconnect switch.
- 2 Turn the pump knob (A) counterclockwise to unlock the plunger.
- 3 Pump approximately 200 to 300 strokes until a heavy resistance can be felt.
- 4 Push the pump knob (A) down and turn clockwise to lock into position.
- 5 Turn on the electric power, start the engine and let it idle at low speed for a few minutes. If the engine is difficult to start, bleed again with the pump knob.

NOTE!

Air bleeding may not be performed using the starter motor.

Fuel tank, draining

Drain the fuel tank when required. If the machine is run with fuel of low quality, it might be necessary to drain more often.

NOTE!

Read the safety when servicing instructions before starting any work.

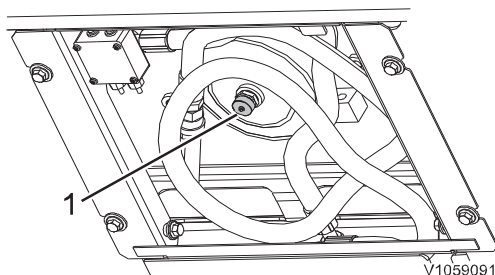

1 - Drain plug below fuel tank

- 1 Fold down the cover under the fuel tank (if a fuel filling pump is installed) or remove the cover under the fuel tank.
- 2 Put the drain hose end into a container.
- 3 Remove the protecting cap and screw the drain hose onto the drain plug (1).
- 4 Drain sludge and water into the container. Disconnect the hose and install the protecting cap.
- 5 Close or reinstall the cover under the fuel tank.

Take care of filters/oils/liquids in an environmentally safe way, see page 249.

306 Maintenance
Maintenance service, when required

Batteries, charging

! WARNING

Risk of serious injury.
Short-circuit, open flames or sparks near a charging battery could lead to an explosion.

Switch off charge current before disconnecting charging cable clamps. Never charge a battery near open flames or sparks.

Always charge a battery in well-ventilated areas.

! WARNING

Risk of chemical burns.

The battery electrolyte contains corrosive sulphuric acid which could cause severe chemical burns.

If electrolyte spilled on your bare skin, remove it immediately and wash the affected area with soap and plenty of water. If it gets into your eyes or any other sensitive body part, rinse with plenty of water and seek immediate medical attention.

- Always turn off the charging current before the charging lead clips are removed.
- Ventilate well, especially if the battery is charged in a confined space.

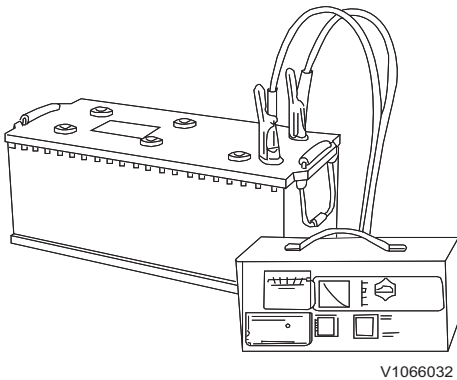

V1066032

Welding

NOTE!

Welding must only be done by a qualified service technician.

The following measures should be taken before starting electric welding on the machine or attachments connected to the machine.

- 1 Turn off the electric power with the battery disconnect switch.
- 2 Disconnect the batteries, both the plus and minus terminal.
- 3 Disconnect all electronic units. For further information, contact an authorised dealer.
- 4 Connect the welding equipment's ground connection as close to the welding point as possible and make sure that the current does not pass across a bearing.
- 5 Ventilate well, specially if the welding is performed in a confine space.
- 6 Remove all paint from an area of at least 10 cm (4 in) around the welding point.

WARNING

Risk of toxin inhalation.

Burning of painted, plastic or rubber parts produces gases that could damage respiratory tracts.

Never burn painted or rubber parts or any plastics.

NOTICE

A fire extinguisher should be easily accessible during all welding work.

NOTE!

The weld will be related with inferior quality and strength, never weld directly on a painted surface.

Headlights, adjusting

The adjustment of the headlamps is very important to avoid dazzling oncoming traffic.

- 1 Place the machine in service position C on level ground at right angles to a wall or similar in distance (B), see page 247.

NOTE!

The battery disconnect switch should be on.

- 2 Turn on the low beams.
- 3 Adjust the upper boundary of the low beams at the height (A) with the 2 adjusting screws on respective side. Check the distance (C) between the centers of the low beams. The distance should be the same as between the headlights on the machine.

NOTE!

Adjusting measurements are shown in the table below.

- 4 Turn off the low beams.

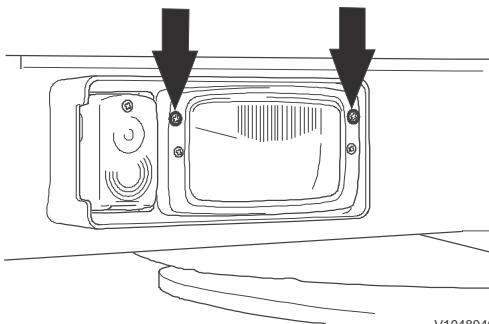

Adjustment screws

V1048046

308 Maintenance
Maintenance service, when required

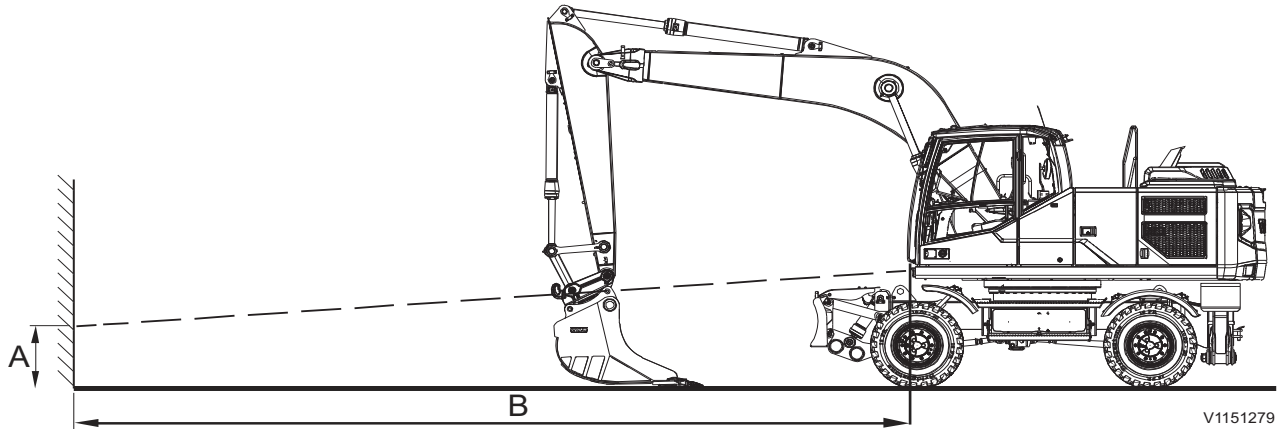

Headlight adjustment

Measurement	EW160E	EW180E
A	1120 mm (3 ft 8.1 in)	1150 mm (3 ft 9.3 in)
B	5000 mm (16 ft 4.9 in)	5000 mm (16 ft 4.9 in)
C	1970 mm (6 ft 5.6 in)	2040 mm (6 ft 8.3 in)



Cleaning machine

The machine should be cleaned regularly with conventional car care products in order to eliminate the risk of damage to the paint finish and other surfaces on the machine.

NOTICE

Avoid using strong cleaning agents or chemicals in order to minimise the risk of damage to the paint finish.

NOTICE

Soil and clay may damage or cause wear to moving parts of the undercarriage. Therefore, all parts must be cleaned regularly from of soil and clay.

NOTE!

Daily clean the areas on the machine where dust, chips and similar may collect in order to minimise the risk of fire, see page 257.

- Place the machine in a place intended for cleaning.
- Follow the instructions supplied with the car care product.
- The water temperature must not exceed 80 °C (176 °F).
- If high-pressure wash is used, keep a distance of at least 40 cm (16 in) between the seals and the nozzle. Keep a distance of 30 cm (12 in) between nozzle and other machine surface. Too high pressure and too short distance may cause damage.

NOTE!

Protect electrical leads in an appropriate way and be careful not to damage the cab prefilter when cleaning the machine.

NOTICE

Do not spray with high pressure into the sealing of the slewing ring, the water may penetrate and affect the characteristics of the grease.

- Use a soft sponge.
- Finish by rinsing the whole machine with only water.
- Always lubricate the machine after washing.
- Touch-up the paint finish when required.

Paint finish maintenance

- Machines which are used in corrosive environment suffer more from rust than others. As a preventive measure it is recommended that the paint finish should be maintained every sixth months.
- At first clean the machine.
- Apply Dinol 77B (or corresponding transparent waxy anti-rust agent) at a thickness of 70-80 µ.
- A protective layer of underseal Dinitrol 447 (or corresponding) may be applied under the mudguards where mechanical wear is expected.

Touch-up painting

- Check if there are any damaged areas of the paint finish.
- At first clean the machine.
- Rectify any damage to paint finish in a professional way.



Cleaning engine compartment

WARNING

Risk of serious injury.
Rotating parts could cause serious cutting or crushing injury.
Never open the engine hood when the engine is running.

WARNING

Risk of burns.
Engine and exhaust system components get very hot and can cause severe burns.
Avoid contact with engine compartment covers, engine components and exhaust system until the engine is cooled down.

Machines operating in dusty environment or environment exposed to fire hazards for example, wood-processing, woodchip handling or grain handling and animal feed industries require daily attention and cleaning of the engine compartment and surrounding areas.

When operating in other environments, inspection and cleaning is required at least once a week.

Loose material is removed with for example compressed air.
Cleaning should preferably be carried out at the end of the working shift before the machine is parked.

Use personal protective equipment such as protective goggles, gloves and respirator.

After cleaning, check and rectify any leaks. Close all covers and hoods.

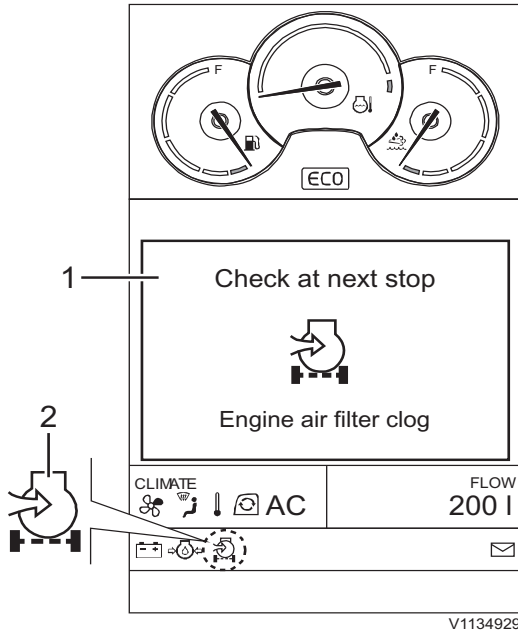

- 1 Check screen
- 2 Indicator

V1134929

Engine air cleaner

The air cleaner prevents dust and other impurities from entering the engine. The air first passes through the primary filter and then the secondary filter.

The degree of engine wear depends largely on the cleanliness of the induction air. Therefore, it is very important that the air cleaner should be checked regularly and maintained correctly. Observe great cleanliness when working with the air cleaner and filters.

NOTICE

Do not, under any circumstances, run the engine without a filter or with a damaged one. Always have a spare filter at hand and keep it well protected from dirt.

Check regularly that hose and pipe connections from the air cleaner to the engine induction manifold do not leak.

Engine air cleaner primary filter, cleaning and replacing

Clean or replace the primary filter if the check screen for engine air filter clog pops up on the IC (Instrument Cluster) or at least once a year. Clean the cover at the same time.

The filter may be cleaned, at the most, five times. Thereafter, the filter should be replaced. Also replace the filter if it is damaged or if the warning lamp is still on after cleaning.

When cleaning the primary filter, mark it on the secondary filter to recognise primary cleaning times.

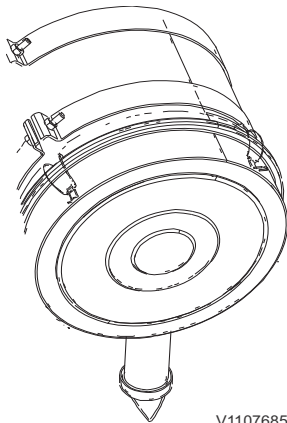

V1107685

Engine air cleaner

Cleaning or replacing the primary filter

NOTE!

Read the safety when servicing instructions before starting any work.

Maintenance 312 Maintenance service, when required

! WARNING

Risk of hazardous inhalation.

Dangerous dust can lead to serious health problems.

Always wear personal protective equipment, including filter mask, eye protection and appropriate gloves when handling and cleaning the engine compartment, coolers and air filters.

NOTICE

Risk of machine damage!

Dust could enter the air intake system if the secondary filter comes off.

If the secondary filter comes off, clean the air cleaner housing thoroughly and make sure no dust enters the air intake system before reinstalling the secondary filter.

- Do not use compressed air.
- Vacuum cleaning is recommended, because it minimizes the risk that dust enters the air intake system.
- A wet cloth may be used but be careful not to push any dust into the air intake system.

- 1 Unfasten the latches and remove the cover.
- 2 Press with both thumbs on primary filter (A) at the same time as you pull it out. This is to prevent secondary filter (B) from coming out together with the primary filter.
- 3 Carefully tap the end of the primary filter against a soft and clean surface.

NOTE!

Do not tap against a hard object.

- 4 If using compressed air when cleaning, do not let the pressure exceed 5bar (73 PSI). Do not hold the nozzle closer than 30–50 mm (1.2–2.0 in).
- 5 Blow the filter from the inside along the folds.
- 6 Check the filter with the aid of a lamp, preferably in a dark room. If there is the smallest hole, scratch, crack or other damage, the filter must be replaced.
- 7 Empty and clean the cover before reinstalling.

Take care of filters/oils/liquids in an environmentally safe way, see page 249.

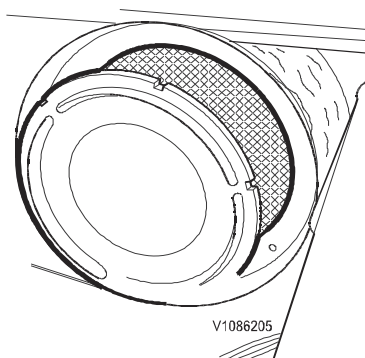

A. Primary filter

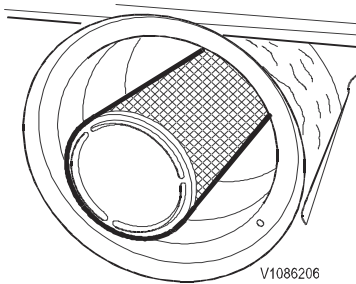

B. Secondary filter

Engine air cleaner secondary filter, replacing

WARNING

Risk of hazardous inhalation.

Dangerous dust can lead to serious health problems.

Always wear personal protective equipment, including filter mask, eye protection and appropriate gloves when handling and cleaning the engine compartment, coolers and air filters.

NOTICE

Risk of machine damage!

Dust could enter the air intake system if the secondary filter comes off.

If the secondary filter comes off, clean the air cleaner housing thoroughly and make sure no dust enters the air intake system before reinstalling the secondary filter.

- Do not use compressed air.
- Vacuum cleaning is recommended, because it minimizes the risk that dust enters the air intake system.
- A wet cloth may be used but be careful not to push any dust into the air intake system.

Replace the secondary filter every third time the primary filter is replaced or at least every second year. If the warning lamp is still alight even though the primary filter has been replaced, the secondary filter must be replaced.

NOTICE

The secondary filter must be replaced, never cleaned. Never remove it unless it is to be replaced.

- 1 Remove the primary filter (A).
- 2 Remove the secondary filter (B) carefully so that no impurities enter the engine.
- 3 Install the new secondary filter. Recheck that the filter is correctly installed.
- 4 Reinstall the primary filter (A).

Take care of filters/oils/liquids in an environmentally safe way, see page 249.

314 Maintenance Maintenance service, when required

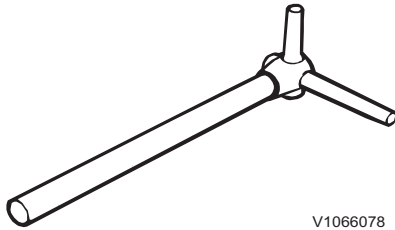

V1066078

Special tool

Bucket teeth, replacing

NOTE!

Read the safety when servicing instructions before starting any work.

WARNING

Risk of splinter injury.

When striking metal objects with a hammer, flying metal chips could cause serious splinter injury to eyes and other body parts. **Always wear personal protective equipment and eye protection when replacing bucket teeth.**

A special tool may be ordered to facilitate replacement of teeth. The tool are available in different sizes depending on tooth size. Contact your dealer for further information.

Removing tooth

- 1 Lower the bucket to the ground and angle it slightly upward.
- 2 Clean the opening for tooth adapter locking device.
- 3 Knock out the locking device with a hammer and the tool or other suitable drift.
- 4 Remove tooth.

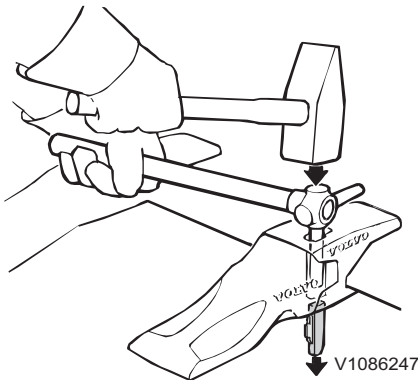

V1086247

Knock out the locking device

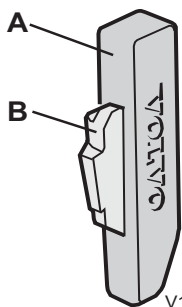

V1086248

Locking device

- A Steel pin
- B Lock retainer

Maintenance
Maintenance service, when required 315

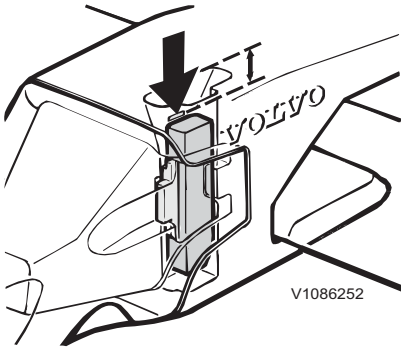

The locking device should be just below the scored line

Installing tooth

- 1 Clean the front part of the tooth adapter and the hole for the locking device.
- 2 Install the tooth so that the guide lugs fit in the tooth adapter recesses.
- 3 Replace lock retainer (B) with a new part.
- 4 Install the locking device so that the chamfered part points downward and the lock retainer points forward.
- 5 Knock down the locking device with a hammer until it is level with the upper part of the tooth adapter.
- 6 Knock down the locking device further with a hammer and the tool or other suitable drift until the upper part is just below the scored line in the hole.

NOTE!

Replace the steel pin in connection with replacement of tooth adapter.



Maintenance
316 Maintenance service, when required

Hydraulic system, releasing pressure

See page 221 for instruction how to release the pressure from the hydraulic system.

Accumulator, handling

WARNING

Risk of serious injury.

Accumulators are charged with highly pressured nitrogen. Improper handling could lead to an explosion causing serious injury.

Work on an accumulator must only be done by a qualified service technician.

- Do not hit, drill or weld the accumulator.
- Keep it away from open flame or other highly heated sources.
- If you operate the operating lever downward just after the engine stops, the accumulator allows the attachment to move by its own weight.
- After releasing the pressure in accumulator, move the control lockout lever down to lock the system securely, see page 110.

Accumulator, emergency operation

- 1 Stop the engine by turning the ignition switch to stop position.
- 2 Turn the ignition switch to running position
- 3 Move the control lockout lever up to unlock the system, see page 110.
- 4 Put the operating lever to boom down position to lower the attachment by its own weight.
- 5 Move the control lockout lever down to lock the system securely.

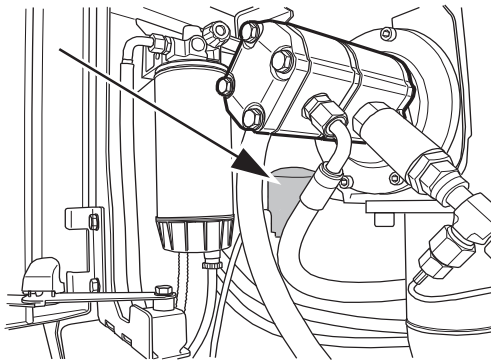

V1152968

Accumulator

Accumulator, pressure releasing

- 1 Lower the attachment completely to the ground.
- 2 Keep all the attachments such as hammer closed.
- 3 After turning off the engine, turn the ignition switch to running position.
- 4 Move the control lockout lever up to unlock the system.
- 5 To release the pressure in the control circuits and accumulator, move the operating levers and pedals forward / rearward and left / right to their respective end positions.
- 6 Turn the ignition switch to stop position.
- 7 Move the control lockout lever down to lock the system securely.

Maintenance
318 Maintenance service, when required

**Automatic lubrication system
(optional equipment)**

The machine may be equipped with an automatic lubrication system which automatically supplies all connected components with their required grease quantity in programmable time intervals. The counter for time intervals starts to run as soon as the ignition is on.

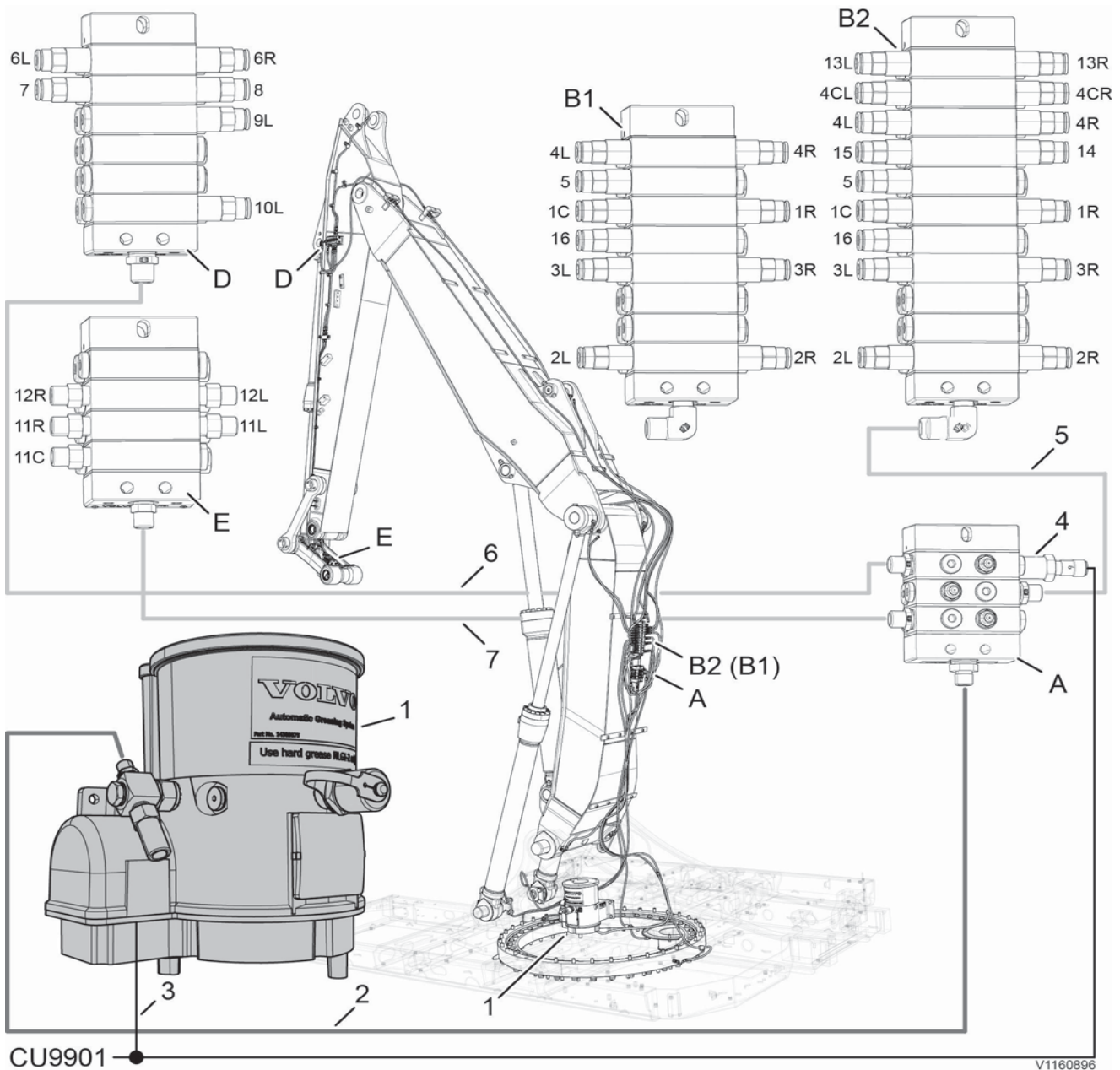

CU9901

V1160896

- A – Master feeder / B1 – Feeder mono boom / B2 – Feeder 2 pcs boom / D – Feeder dipper arm / E – Feeder bucket link
- 1 Lubrication unit with pump control unit
- 2 Main line
- 3 Cable connection
- 4 Cycle switch SE9901
- 5 Secondary line
- 6 Secondary feeder for boom and slew ring
- 7 Secondary feeder for dipper arm
- 8 Secondary feeder for bucket link (option, if not installed, the grease feed line from master feeder is connected to lubrication unit.)

Maintenance
Maintenance service, when required 319

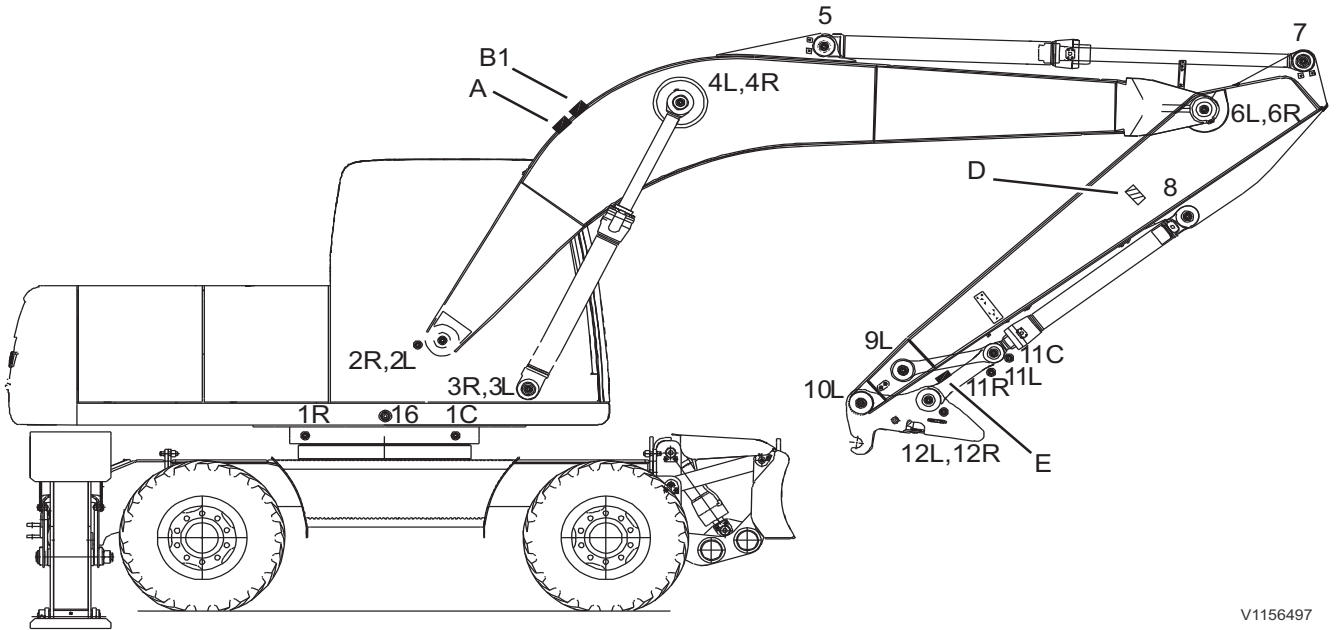

Mono boom

V1156497

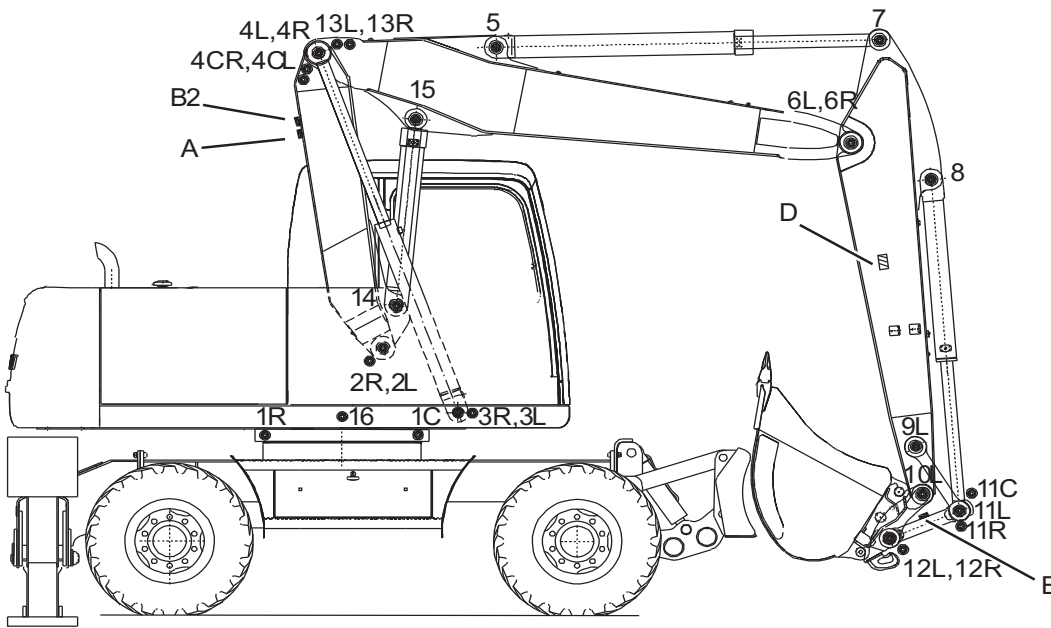

2 piece boom

V1156498

NOTE!

Remember to grease the greasing points which are not included in the automatic lubrication system by hand.

Maintenance
320 Maintenance service, when required

Lubrication unit

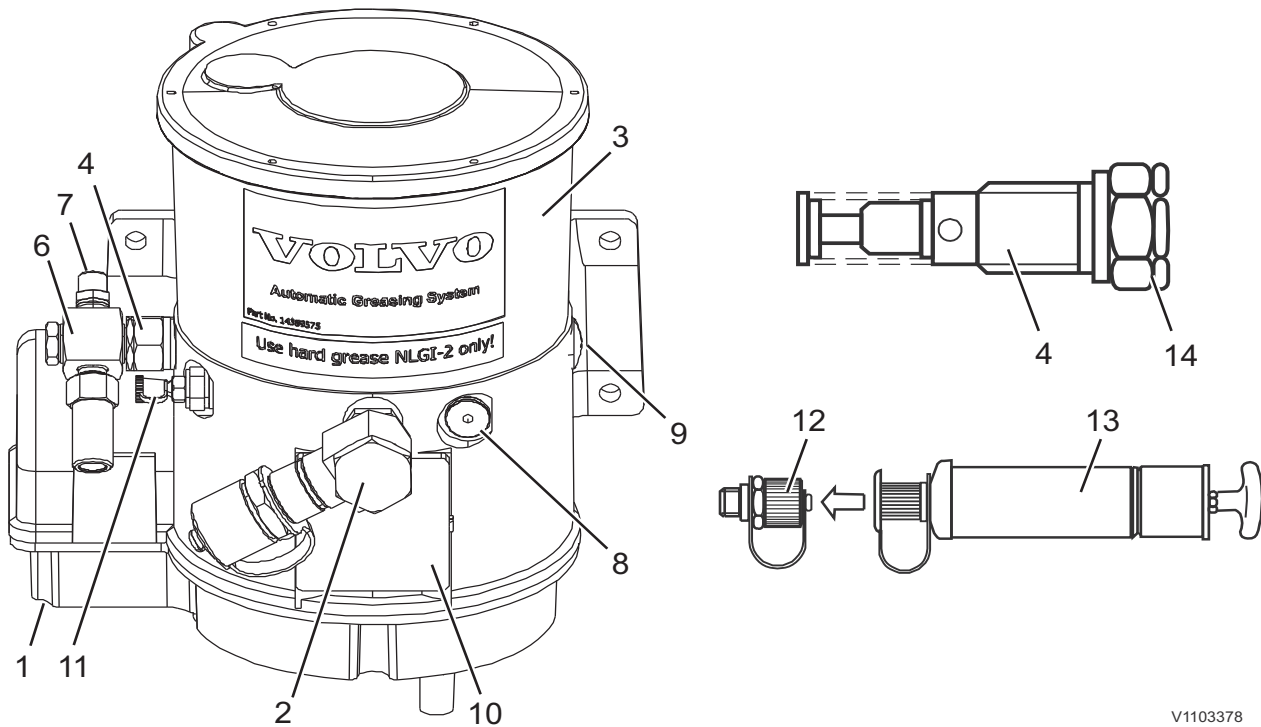

V1103378

Automatic lubrication pump

- 1 Electrical connection (DC 24V, Fuse 3A)
- 2 Grease filling or pump unit installing port
- 3 Lubrication reservoir
- 4 Pump element
- 5 Port for hand pump
- 6 Pressure limiting valve
- 7 Connection to main line
- 8 Grease filling port
- 9 Grease filling or pump unit installing port
- 10 Pump control unit
- 11 Grease filling port
- 12 Grease filling port coupler
- 13 Grease filling cylinder
- 14 Location of groove (1 place)

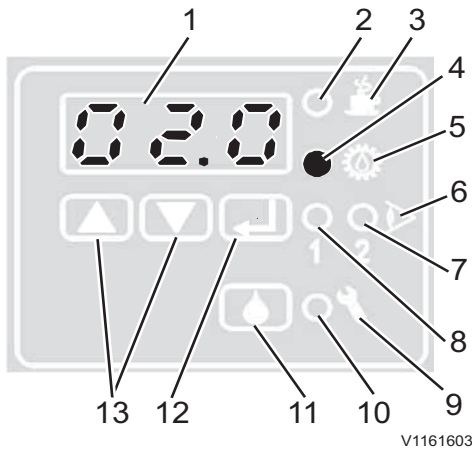

V1161603

Pump control unit

- 1 Display for programmed values and parameters (normally off)
- 2 LED indicating pump pause period
- 3 Symbol for pump pause period
- 4 LED indicating pump running period (contact time)
- 5 Symbol for pump running period
- 6 Symbol for pump monitoring
- 7 LED2 (not valid for Volvo excavator)
- 8 LED1 indicating cycle switch sends signal
- 9 Symbol for system malfunction
- 10 LED indicating system malfunction
- 11 Button for additional lubrication and cancel an error message
- 12 Button for changing display and program mode and for setting values and parameters
- 13 Buttons for setting and displaying values and parameters, and activating the display

Additional lubrication

If greasing is necessary more often due to hard or wet conditions, additional lubrication can be carried out without any change of the control unit set value.

The engine must be turned off, then turn the ignition switch to position "ignition ON" and press the button for additional lubrication (11).

Cycle switch

The cycle switch checks system functions during pump operating time. If the grease does not flow, the IC (Instrument Cluster) shows a "check" message and a red fault marker is displayed in the pump control unit.

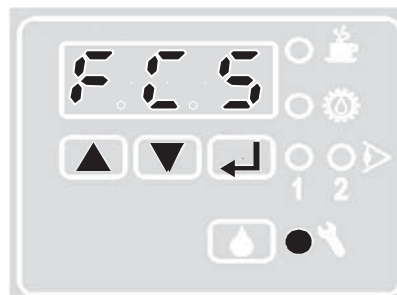
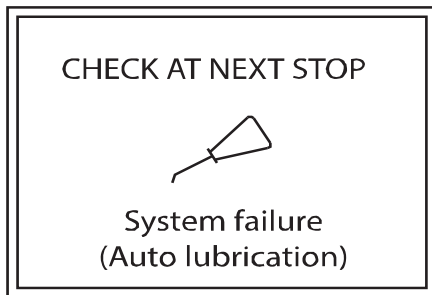

V1161605

Cycle switch fault signal (Instrument cluster / Pump control unit)

Grease filling

NOTE!

Over lubrication or under lubrication can cause damage to the machinery.

Maintenance 322 Maintenance service, when required

If the grease quantity in the lubrication unit is below a certain level, the IC (Instrument Cluster) shows a “check” message and a red fault marker is displayed in the pump control unit. In this case the pump cannot be operated.

Refill the grease reservoir to at least 2/3 of the reservoir volume using the filling port.

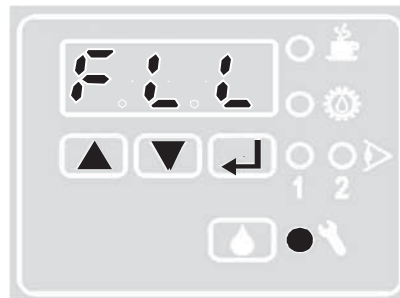
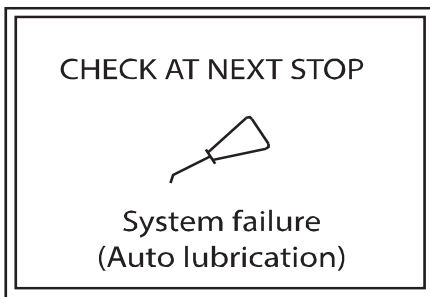

V1161604

Error message for filling level (Instrument cluster / Pump control unit)

NOTE!

Do not fill above the maximal filling height. The venting hole might be clogged and this cause the system malfunction.

Do not fill grease through the open lid.

Maintenance service, general

NOTE!

All further service work other than the measures described below must be conducted by a qualified service technician only.

NOTE!

The service life of the pump elements is dependent on the purity of the grease used.

Checking the filing level

Visual checking:

The transparent lubrication vessel allows visual checking of the filling level.

Inspect regularly, if the grease level is below the minimum mark the entire system has to be bled.

Automatic checking:

The automatic lubrication system is provided with automatic checking of the filling level.

A message appears in the IC (Instrument Cluster) and the pump control unit.

NOTE!

Fill only with clean lubricant through the filling port using a suitable tool.

Never open the pump lid to fill in the grease to the reservoir.

Contaminated lubricant leads to serious system trouble!

Checking the system faults

The cycle switch LED in the pump control unit and the message “CS” are flashed during the pump operation.

Check for any fault signals in the IC (Instrument Cluster) and the pump control unit after the lubrication system has stopped working.

When the cycle switch does not get a signal during the pump running time, the system goes to “Block mode”. If the message “bLo” persists during three running cycles, a fault signal is created in the pump control unit and the IC (Instrument Cluster). Contact a qualified service technician to repair the system.



Maintenance

Maintenance service, when required 323

When the system is blocked, the pressure limiting valve will open and the grease emerges from the upper side of the pressure limiting valve.

NOTE!

Never close the feeder outlet port if the line is damaged.

Contact a qualified service technician if the following occurs:

- the "check" screen for cycle switch fault is shown
- emergence of grease at pressure-limiting valve
- the "check" screen for filling is still shown after filling grease

Scheduled maintenance overview:

Checking items	Interval	Actions
Grease filling level visual inspection	Daily	If needed, refill the reservoir up to the maximum level.
Is there grease coming out of the pressure limiting valve?	Daily	Check the system. In case of blocked feeder or lubrication points contact a qualified service technician.
Is there any error message related to the lubrication system on IC (Instrument Cluster)?	ongoing	Check the error codes from the pump control unit.
Are lines and connections damaged?	every 40 hours	In case of damages contact a qualified service technician to replace the lines and connections.
Do the grease collars at the lubrication points show sufficient grease?	every 40 hours	If there is not enough grease, check for system damage. Also check the pump control unit setting values.

Maintenance
324 Maintenance service, when required

Manually greasing in case of pump failure

NOTICE

In case the automatic lubrication stops due to pump failure, it is very important that lubrication is carried out manually through the greasing nipples shown below.

NOTE!

Read the safety when servicing instructions before starting any work.

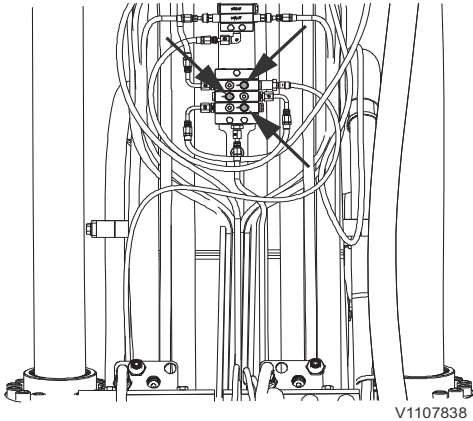

V1107838

Main distributor, 3 grease nipples

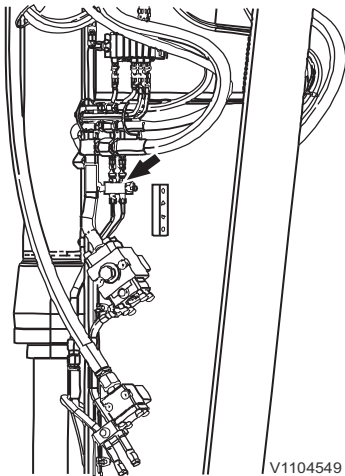

V1104549

Left-hand side dipper arm, 2 grease nipples

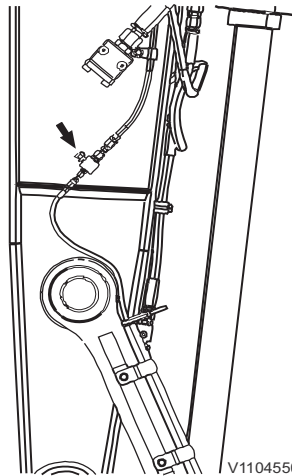

V1104550

Right hand side dipper arm, 1 grease nipple (only if bucket link distributor is installed)



Recommended intervals for critical parts

To ensure safety at all times when operating or driving the machine, periodic maintenance must always be carried out. To maintain safety over time, it is also recommended that periodic check or replacement of the parts given in the table below, is carried out.

These parts are closely connected to safety and fire prevention. The material ages or materials are wearing with foreseeable deterioration. If these parts show any abnormality before the recommended interval has passed, they should be repaired or replaced immediately. If the hose clamps show any deterioration, such as deformation or cracking, replace the clamps at the same as the hoses. When replacing the hoses, always replace the O-rings, gaskets, and other related parts at the same time. The replacements should be carried out by a qualified service technician.

Inspection interval	Item
Daily	Fuel / hydraulic hoses - leakage of connections and end fittings
Monthly	Fuel / hydraulic hoses - leakage, damage of connections and end fittings
Yearly	Fuel / hydraulic hoses - leakage, damage, deformity and aging of connections and end fittings

Critical parts list for periodic replacement	Recommended interval
Fuel hoses	Every 2 years or 4000 hours, which occurs first
Hydraulic hoses	Every 6 years or 6000 hours, which occurs first
Seat belt	Every 3 years



326 Maintenance
Maintenance service, when required

Maintenance under special environmental conditions

Conditions	Maintenance
Water or near the ocean	Before operating, check the tightness of plugs and all drain hoses and cocks.
	After working, replenish the grease to the attachment pins or the areas affected by the water.
	When operating the machine, make sure to check and lubricate attachment points affected by water regularly.
	After working near the ocean, clean the machine thoroughly with fresh water and service the electrical parts to prevent from corrosion. It is highly recommended to use dielectric grease in all harness connecting points for better sealing and to prevent corrosion.
Freezing weather	After working, fill up the fuel tank to prevent water from condensing in the tank.
	Use the recommended lubricants.
	Fully charge the batteries regularly, electrolyte may freeze. Ventilate well especially when the batteries are charged in a confined space.
	When storing machines in extremely cold temperature, remove batteries and parking them at room temperature.
	Before parking, remove the mud and the dirt from the tyres.
Demolition work	Use fall protection against falling objects.
Low fuel quality	Drain the sediments in fuel tank at shorter service intervals.
	Change the engine oil and engine oil filter at shorter service intervals.
Dusty atmosphere	Check regularly that hose and pipe connections from the air cleaner to the engine induction manifold do not leak.
	Clean the air filter at shorter service intervals.
	Clean the clogging net for radiator and oil cooler at shorter service intervals.
	Clean the areas on the machine where dust, chips and similar may collect at shorter service intervals in order to minimize the risk of fire.
	Pay attention to and clean the engine compartment and surrounding areas regularly.
Rocky ground	Use suitable tyres for the ground conditions. If in doubt, contact an authorised dealer for information.
	Use a suitable attachment for the ground conditions such as a heavy duty bucket.
Hammer operation	Change the hydraulic oil and return filter of hammer circuit at shorter service intervals.



Specifications Recommended lubricants

Recommended lubricants

Oils and lubricants

The Volvo lubricants have been specially developed to fulfil the demanding operating conditions, in which Volvo's machines are used in. The oils have been tested according to Volvo's specifications and therefore meet the high requirements for safety and quality.

Other mineral oils can be used if they conform to our viscosity recommendations and meet our quality requirements. The approval of Volvo is required, if any other oil base quality (e.g. biologically degradable oil) is to be used.

Engine oil

NOTE!

It is very important that instructions for oil grade are followed, otherwise deposits from the oil may clog the particle filter (DPF).

Engine	Oil grade	Recommended viscosity at varying ambient temperatures																											
	Volvo Engine Oil VDS-4	<table style="width: 100%; border-collapse: collapse;"> <tr> <td style="text-align: center;">°C</td> <td style="text-align: center;">-30</td> <td style="text-align: center;">-20</td> <td style="text-align: center;">-10</td> <td style="text-align: center;">0</td> <td style="text-align: center;">+10</td> <td style="text-align: center;">+20</td> <td style="text-align: center;">+30</td> <td style="text-align: center;">+40</td> </tr> <tr> <td style="text-align: center;">°F</td> <td style="text-align: center;">-22</td> <td style="text-align: center;">-4</td> <td style="text-align: center;">+14</td> <td style="text-align: center;">+32</td> <td style="text-align: center;">+50</td> <td style="text-align: center;">+68</td> <td style="text-align: center;">+86</td> <td style="text-align: center;">+104</td> </tr> <tr> <td colspan="9" style="text-align: center;"> </td> </tr> </table>	°C	-30	-20	-10	0	+10	+20	+30	+40	°F	-22	-4	+14	+32	+50	+68	+86	+104									
	°C		-30	-20	-10	0	+10	+20	+30	+40																			
	°F		-22	-4	+14	+32	+50	+68	+86	+104																			
Volvo Engine Oil VDS-4.5																													
Other approved VDS-4 engine oil, VDS-4.5 engine oil, in accordance with specification: – ACEA: E9 – API: CJ-4 or CK-4																													

V1177225
*) VDS-4 or VDS-4.5 approved oils only. Other oils can be used up to +30 °C (86 °F).

Changing intervals vary according to oil grade and sulfur content in fuel:

Oil grade	Sulphur content in the fuel	
	< 15 ppm	> 15 ppm
	Oil change interval	
Volvo Engine Oil VDS-4	500 hour	Not allowed!
Volvo Engine Oil VDS-4.5	500 hour	Not allowed!
ACEA: E9	250 hour	Not allowed!
API: CJ-4 or CK-4	250 hour	Not allowed!



Specifications
328 Recommended lubricants

Hydraulic oil

Hydraulic system	Oil grade	Recommended viscosity at varying ambient temperatures								
		°C -30	-20	-10	0	+10	+20	+30	+40	+50
Volvo Hydraulic Oil Volvo 98620 Ultra	Volvo Hydraulic Oil Volvo 98608 Super	°F -22	-4	+14	+32	+50	+68	+86	+104	+122
		ISO VG 32								
		ISO VG 46								
		ISO VG 68								
		Bio oil VG 32								
		Bio oil VG 46								
		V1068659								

a) If the machine is filled with Volvo Biodegradable Hydraulic oil this oil must also be used when filling and changing. The mineral oil content in bio oil should not exceed 2%. If changing from mineral oil to bio oil, contact a workshop authorised by Volvo CE.

Changing intervals vary according to type of oil:

Hydraulic oil	Change interval
Volvo Hydraulic Oil Volvo 98620 Ultra	every 5000 hour
Volvo Hydraulic Oil Volvo 98608 Super	every 4000 hour
Volvo Hydraulic Oil Volvo 98610 Biodegradable	every 2000 hour



Specifications
Recommended lubricants **329**

Axle oil

	Oil grade	Recommended viscosity at varying ambient temperatures																																																		
Axles and hub reductions	Volvo Wet Brake Oil Volvo 97303 WB101	<table border="1" style="width: 100%; text-align: center;"> <tr> <td>°C</td> <td>-30</td> <td>-20</td> <td>-10</td> <td>0</td> <td>+10</td> <td>+20</td> <td>+30</td> <td>+40</td> <td>+50</td> </tr> <tr> <td>°F</td> <td>-22</td> <td>-4</td> <td>+14</td> <td>+32</td> <td>+50</td> <td>+68</td> <td>+86</td> <td>+104</td> <td>+122</td> </tr> <tr> <td colspan="10" style="background-color: #e0e0e0;">SAE 90</td> </tr> <tr> <td colspan="10" style="background-color: #e0e0e0;">SAE 140</td> </tr> <tr> <td colspan="10" style="background-color: #e0e0e0;">SAE 80W/90 or 85W/90</td> </tr> </table>	°C	-30	-20	-10	0	+10	+20	+30	+40	+50	°F	-22	-4	+14	+32	+50	+68	+86	+104	+122	SAE 90										SAE 140										SAE 80W/90 or 85W/90									
	°C		-30	-20	-10	0	+10	+20	+30	+40	+50																																									
°F	-22	-4	+14	+32	+50	+68	+86	+104	+122																																											
SAE 90																																																				
SAE 140																																																				
SAE 80W/90 or 85W/90																																																				
	alternatively: Volvo Axle Oil Limited Slip 85W-90 GL-5																																																			

V1068657

Changing intervals vary according to load class:

Lubricant	Volvo Axle Oil Limited Slip 85W-90	Volvo Wet Brake Oil Volvo 97303 WB101
Load class	Oil change interval	
1 Proportion driving time to operating hours < 25%	1500 h	2000 h
2 Proportion driving time to operating hours > 25%	1000 h	1500 h
3 Machine operated in outdoor temperatures >40 °C (104 °F)	500 h	1000 h

Travel gearbox

	Oil grade	Recommended viscosity at varying ambient temperatures																														
Travel gearbox	Volvo Engine Oil VDS-3 15W-40	<table border="1" style="width: 100%; text-align: center;"> <tr> <td>°C</td> <td>-30</td> <td>-20</td> <td>-10</td> <td>0</td> <td>+10</td> <td>+20</td> <td>+30</td> <td>+40</td> <td>+50</td> </tr> <tr> <td>°F</td> <td>-22</td> <td>-4</td> <td>+14</td> <td>+32</td> <td>+50</td> <td>+68</td> <td>+86</td> <td>+104</td> <td>+122</td> </tr> <tr> <td colspan="10" style="background-color: #e0e0e0;">SAE 15W/40</td> </tr> </table>	°C	-30	-20	-10	0	+10	+20	+30	+40	+50	°F	-22	-4	+14	+32	+50	+68	+86	+104	+122	SAE 15W/40									
	°C		-30	-20	-10	0	+10	+20	+30	+40	+50																					
°F	-22	-4	+14	+32	+50	+68	+86	+104	+122																							
SAE 15W/40																																
	Volvo Engine Oil VDS-4 15W-40																															
	Other engine oil, in accordance with specification: – API CD / CE / CF-4 / CF / CG-4 / CH-4 / CI-4 / CI-4 Plus / CJ-4 – API SF / SG / SH / SJ / SL / SM – ACEA-categories A / B / E																															

V1068656



Specifications
330 Recommended lubricants

Swing gearbox

	Oil grade	Recommended viscosity at varying ambient temperatures																																																														
Swing gearbox	Volvo Axle Oil 80W-90 GL-5	<table border="1"> <tr> <td>°C</td> <td>-30</td> <td>-20</td> <td>-10</td> <td>0</td> <td>+10</td> <td>+20</td> <td>+30</td> <td>+40</td> <td>+50</td> </tr> <tr> <td>°F</td> <td>-22</td> <td>-4</td> <td>+14</td> <td>+32</td> <td>+50</td> <td>+68</td> <td>+86</td> <td>+104</td> <td>+122</td> </tr> <tr> <td></td> <td></td> <td></td> <td></td> <td></td> <td></td> <td></td> <td></td> <td></td> <td></td> </tr> <tr> <td></td> <td></td> <td colspan="5" style="text-align: center;">SAE 90</td> <td></td> <td></td> <td></td> <td></td> </tr> <tr> <td></td> <td></td> <td></td> <td></td> <td></td> <td colspan="4" style="text-align: center;">SAE 140</td> <td></td> <td></td> </tr> <tr> <td></td> <td></td> <td></td> <td></td> <td></td> <td></td> <td></td> <td></td> <td></td> <td></td> </tr> </table>	°C	-30	-20	-10	0	+10	+20	+30	+40	+50	°F	-22	-4	+14	+32	+50	+68	+86	+104	+122													SAE 90														SAE 140															
	°C	-30	-20	-10	0	+10	+20	+30	+40	+50																																																						
	°F	-22	-4	+14	+32	+50	+68	+86	+104	+122																																																						
		SAE 90																																																														
					SAE 140																																																											
	Volvo Axle Oil 85W-140 GL-5																																																															
	Gear oil (with EP additive) (a) API GL4 or GL5																																																															

V1108125

a) EP = extreme pressure

Grease

	Oil grade	Recommended viscosity at varying ambient temperatures																																									
Grease Pins and bushings Swing ring gear Automatic lubrication system	Volvo Lithium Grease EP2 (a)	<table border="1"> <tr> <td>°C</td> <td>-30</td> <td>-20</td> <td>-10</td> <td>0</td> <td>+10</td> <td>+20</td> <td>+30</td> <td>+40</td> <td>+50</td> </tr> <tr> <td>°F</td> <td>-22</td> <td>-4</td> <td>+14</td> <td>+32</td> <td>+50</td> <td>+68</td> <td>+86</td> <td>+104</td> <td>+122</td> </tr> <tr> <td></td> <td></td> <td></td> <td></td> <td></td> <td></td> <td></td> <td></td> <td></td> <td></td> </tr> <tr> <td></td> <td></td> <td colspan="7" style="text-align: center;">NLGI EP2 grease</td> <td></td> <td></td> </tr> </table>	°C	-30	-20	-10	0	+10	+20	+30	+40	+50	°F	-22	-4	+14	+32	+50	+68	+86	+104	+122													NLGI EP2 grease								
	°C	-30	-20	-10	0	+10	+20	+30	+40	+50																																	
°F	-22	-4	+14	+32	+50	+68	+86	+104	+122																																		
		NLGI EP2 grease																																									
	Or corresponding grease on lithium base with EP additives and consistency NLGI class 2.																																										

V1180947

a) EP = extreme pressure



Coolant

Only use Volvo Coolant VCS when topping up or changing coolant. To avoid damage to engine and cooling system, different coolants or corrosion protection must not be mixed.

When using concentrated Volvo Coolant VCS and clean water, the mixture should contain 40–60% concentrated coolant and 60–40% clean water. The amount of concentrated coolant must never be less than 40% of the total mixture, see table below.

Freeze protection down to	Mixed-in amount of concentrated coolant
-25 °C (-13 °F)	40%
-35 °C (-31 °F)	50%
-46 °C (-51 °F)	60%

The concentrated coolant must not be mixed with water that contains a high degree of lime (hard water), salt or metals.

The clean water for the cooling system must also meet the following requirements:

Description	Value
Total number of solid particles	< 340 ppm
Total hardness	< 9.5° dH
Chloride	< 40 ppm
Sulphate	< 100 ppm
pH value	5.5-9
Silica	< 20 mg SiO ₂ /litre
Iron	< 0.10 mg Fe/litre
Manganese	< 0.05 mg Mn/litre
Electrical conductivity	< 500 µS/cm
Organic material, COD-Mn	< 15 mg/litre

If there is any doubt about the water quality, use ready-mixed Volvo Coolant VCS, which contains 40% concentrated coolant. Do not mix with any other ready-mixed coolants since this may result in engine damage.



332 Specifications
Fuel system

Fuel system

Fuel

Fuel quality requirements

The fuel should at least meet the legal requirements, national and international standards for marketed fuels, for example: EN590 (with nationally adapted temperature requirements), ASTM D 975 No. 1D and 2D, JIS KK 2204. Fuel specification varies according to the working temperature. Please contact authorized Volvo dealer.

Sulphur content

According to current USA legal requirement, the sulphur content in the diesel fuel must not exceed 0.0015 percent (15 ppm) by weight.

According to current EU/other countries legal requirements, the sulphur content in the diesel fuel must not exceed 0.001 percent (10 ppm) by weight.

Bio-diesel fuel

Vegetable oils and / or esters, also called "bio-diesel", (e.g. rape-seed methyl ester RME fuel), which are offered on certain markets both as pure products and as mixed into the diesel fuel.

Volvo Construction Equipment accepts a maximum intermix of 7% bio-diesel fuel in the diesel fuel, ready mixed from the oil companies. A higher intermix than 7% of bio-diesel fuel may cause:

- Increased emission by nitrogen oxide, (thereby not meeting legal requirements)
- Shorter service life of engine and injection system
- Increased fuel consumption
- Altered engine output
- Shortening the engine oil change interval to a half
- Shortened service life of rubber materials in the fuel system
- Less good cold handling properties of the fuel
- Limit storage time for the fuel, which may cause clogging up of the fuel system if the machine is laid up for longer periods

Warranty condition

The warranty does not cover damage caused by an intermix of more than 7% of bio-diesel fuel.

Alternative fuels

This statement is only valid for Volvo branded engines.

Hydro-treated vegetable oil (HVO) and fatty acid methyl ester (FAME) biodiesel are both made from renewable raw materials such as vegetable oils and animal fats, but they are chemically processed in different ways.

Hydro-treated vegetable oil (HVO)

HVO is created using a chemical process called hydro-treating. Hydro-treating creates an oxygen-free hydrocarbon product that is very similar to distillate diesel fuel and is well suited for use in diesel engines. HVO fuels complying with the CEN diesel fuel standard EN 590:2013 or with the European Fuel Quality Directive 98/70/EC are approved for use in all Volvo Construction Equipment diesel engines with no changes to maintenance intervals. Paraffinic diesel fuels complying with the CEN standard EN 15940 may be used in all machines operating outside the European Union and for EU-certified engines up to the emission level Stage IV. These fuels may also be used for the EU-certified D11, D13 and D16 engines meeting the emission level Stage V.

Biodiesel

Biodiesel is a product made from renewable resources such as vegetable oils or animal fat. Biodiesel that has been chemically processed into fatty acid methyl ester (FAME) can be blended with distillate diesel fuel and used in some diesel engines.



Unblended biodiesel is referred to as B100 because it is 100% biodiesel.

Rapeseed methyl ester (RME) is the most common type of FAME used in Europe. Soy methyl ester (SME) and sunflower oil methyl ester (SOME) are the most common types of FAME used in the US.

Although use of FAME biodiesel is now a legal requirement in some markets, it is not as suitable for use in diesel engines as conventional diesel fuel or HVO (hydro-treated vegetable oil).

Biodiesel fuel requirements

The FAME biodiesel blends specified in the table below are approved for use if:

- The biodiesel is pre-blended by the fuel supplier
- The biodiesel used in the blend conforms to EN14214 or ASTM D6751
- The distillate fuel used in the blend meets fuel sulphur requirements
- The distillate fuel used in the blend conforms to EN590 or ASTM D975
- B1-B5 biodiesel blends conform to EN590 or ASTM D975
- B6-B7 biodiesel blends conform to EN590 or ASTM D7467
- B8-B20 biodiesel blends conform to EN16709(B20) or ASTM D7467

Engine emission designation	Engine size	Acceptable blend
EU Stage II / US Tier 2 * EU Stage IIIA / US Tier 3 * EU Stage IIIB / US Tier 4 interim EU Stage IV / US Tier 4 final EU Stage V	Below D4 / 4 litres	Up to B7
EU Stage II / US Tier 2 * EU Stage IIIA / US Tier 3 * EU Stage IIIB / US Tier 4 interim EU Stage IV / US Tier 4 final	D4–D8	Up to B7
EU Stage II / US Tier 2 * EU Stage IIIA / US Tier 3 * US Tier 4 final, special North America arrangement **	D9–D16	Up to B20
EU Stage IIIB / US Tier 4 interim EU Stage IV / US Tier 4 final	D11–D16	Up to B10
EU Stage IIIB / US Tier 4 interim, equipped with High Sulphur Fuel Conversion Kit (only available in unregulated markets) EU Stage IV / US Tier 4 final, equipped with High Sulphur Fuel Conversion Kit (only available in unregulated markets)	D4–D16	Up to B20



Engine emission designation	Engine size	Acceptable blend
EU Stage V	D4–D16	Up to B7
<p>* As Tier 2 and Tier 3 emissions regulations ended in 2005 and 2010 respectively, engines produced since then typically meet Stage II / Stage IIIA regulations, allowing their sale in less regulated markets.</p> <p>** With additional restrictions and special operating conditions, equipment used in North America may operate on B20 diesel.</p>		

NOTE!

Failures directly caused by the use of poor quality biofuel, or any other fuel not conforming to standards, are not factory defects and the manufacturer's warranty does not apply.

Maintenance interval requirements

Additional service actions and shorter maintenance intervals are mandatory when using biodiesel blends above B10.

Every 10 hours
<ul style="list-style-type: none"> - Check the engine oil and change if it rises above the maximum fill level - Inspect the fuel system components and replace as necessary
Half of original interval
<ul style="list-style-type: none"> - Change the engine oil and filter - Replace the fuel filter(s)
Every year, regardless of operating hours
<ul style="list-style-type: none"> - Change the engine oil and filter - Clean the fuel tank

Effects of biodiesel on engine oil

Using biodiesel can lead to increased oil dilution. Use engine oil analysis tools frequently to check for fuel dilution and monitor engine oil condition. Check the engine oil level daily. Always change the engine oil if the oil level rises above the maximum fill level.

Effects of biodiesel on fuel systems

Biodiesel dissolves and loosens some fuel system deposits. During the initial conversion to biodiesel, loosened deposits will travel to the fuel filters and require more frequent fuel filter replacements. Start with new fuel filters when using biodiesel for the first time.

Biodiesel is aggressive to some materials used in fuel system components. Inspect seals, hoses, rubber and plastic components every 10 hours. Repair or replace any components that are damaged, softened or leaking. Clean biodiesel from painted surfaces immediately to prevent paint damage.

Biodiesel is more sensitive to bacteria and water contamination than distillate diesel fuel.

- Use as much fuel as possible before refilling the fuel tank in order to prevent bacteria growth if a machine is in regular use, e.g. regularly uses up a tank of fuel within a week. In climates where condensation is a risk, or when the machine is working for short durations, keep the fuel tank full.
- Do not use biodiesel in machines with low utilization or operating time.
- Do not store machines for more than 4 weeks without flushing biodiesel out of the fuel system by operating the machine through at least one full tank of distillate diesel fuel.



- Always follow the manufacturer's storage recommendations and "best-before" dates for each delivery of biodiesel.

Effects of biodiesel on exhaust aftertreatment systems

Biodiesel leaves higher levels of ash in diesel particulate filters and may require more frequent diesel particulate filter (DPF) regeneration and cleaning. Biodiesel can cause deviations in temperatures and functionality of the DPF burner and may cause fault codes or errors.

Biodiesel exhaust gas is aggressive to some materials used in selective catalytic reduction systems (SCR) and may require more frequent cleaning, repairing or replacing of SCR parts.

Effects of biodiesel on cold weather operation

Biodiesel has a high viscosity at temperatures below 0 °C (32 °F) and may cause problems starting the engine. Use a fuel heater or park machines in a heated building if possible.

Effects of biodiesel on engine performance

Biodiesel B100 has about 8% lower energy density compared to regular diesel fuel. Blends equal or lower than B20 have a small impact on engine performance.

Effects of biodiesel on emissions compliance

Engines are certified to comply with U.S. EPA, California and EU emissions standards based upon the use of test fuels with specifications established by these regulatory agencies.

Alternative fuels, including biodiesel, that are not substantially similar to the required test fuels may adversely affect engine emissions compliance. As a result, Volvo does not warrant that the engine will conform to applicable Federal or California and EU emissions limits when operated on, or having previously being operated on, biodiesel or other alternative fuels that are not substantially similar to specified test fuels used for certification, nor if biodiesel / regular diesel is used in blends that exceed the recommendations.

However, the use of biodiesel up to a maximum of 20% (B20) in and of itself, will not affect the manufacturer's mechanical warranty as to engine or emissions system, provided the bio fuel used in the blend conforms to the applicable standards and the additional steps outlined herein are followed.



336 Specifications Fuel system

AdBlue®/DEF

NOTICE

Risk of machine damage.

In the short term, use of the wrong fluid can lead to reduced engine power. In the long term, it can lead to damage to the SCR-system and the catalyst. Reusing AdBlue®/DEF can lead to contamination. Damages caused by the use of incorrect fluids will not be covered by the warranty.

Always use fluid specified in ISO 22241-1. Do not reuse drained AdBlue®/DEF.

For reducing nitrogen oxides (NO_x) the engine is equipped with a selective catalytic reduction (SCR) system.

A diesel exhaust fluid is needed for the process to work. The fluid is called AdBlue® in Europe and Asia, but in North America it is called Diesel Exhaust Fluid (DEF). When needed, the SCR system warms up the AdBlue®/DEF-tank and lines.

The fluid is filled in a separate tank, which is completely separated from the fuel tank. AdBlue®/DEF may not be mixed in the fuel tank and fuel may not be mixed in the AdBlue®/DEF-tank.

AdBlue®/DEF consists of urea crystals (32.5%) and distilled water (67.5%). It is transparent, clear, and has a slight odour of ammonia. The fluid is not considered to be hazardous, but should still be handled with care. It is very corrosive, especially with copper and aluminium. For this reason, avoid spilling the fluid on electric cables and components. Always wipe up any spilled AdBlue®/DEF.

AdBlue®/DEF is not a combustible product. When exposed to high temperatures it will convert to ammonia and carbon dioxide. The fluid should not come into contact with other chemicals or be mixed with other chemicals.

AdBlue®/DEF is sensitive to both high and low temperatures. It should not be exposed to direct sunlight for any extended period of time. If the machine is not in use, AdBlue®/DEF starts to freeze at -11 °C (12 °F). The fluid volume in the tank increases when frozen, this is why it is important to follow the recommended fill volume. AdBlue®/DEF does not break down or degrade when it freezes. The SCR-system will thaw the fluid so that it regains its concentration with maintained quality. The machine will work normally during the time that the fluid melts.

At AdBlue®/DEF temperatures above 20 °C (68 °F) the fluid starts to degrade. Then the fluid gives off ammonia, which is aggressive to materials such as rubber. At temperatures above 75–80 °C (167–176 °F), ammonia production increases. However, high temperatures are permitted for a short time.

AdBlue®/DEF should be stored in a cool, dry, and ventilated place. The fluid may not be stored in direct sunlight. The recommended storage temperature for AdBlue®/DEF is between -11 °C (12 °F) and 25 °C (77 °F). Under these conditions, storage life is approx. two years. Long-term storage of AdBlue®/DEF at a temperature above 25 °C (77 °F) can reduce the lifetime of the fluid. A short time exposure to higher temperatures has no impact on the quality.

NOTE!

If the machine is to be parked for an extended period of time (several months) in ambient temperatures above 40 °C (104 °F) the tank must be drained. This to prevent the fluid from having the wrong quality when starting the machine or that precipitates have a negative impact on the component parts.

NOTE!

If the tank has been drained completely it should be rinsed out with new AdBlue®/DEF before new fluid is filled. Never reuse old fluid. If distilled water or ordinary water is used when rinsing there is a risk that the system will generate an alarm due to wrong quality of AdBlue®/DEF.

NOTE!

Water of any kind should not be used when cleaning AdBlue®/DEF system or AdBlue®/DEF components since there is a risk that even a small amount of water remains in the system after cleaning. The only exceptions allowed are operations described in the service information made by Volvo.

AdBlue®/DEF is available in plastic container, barrel, IBC, or bulk.

For information on ordering AdBlue®/DEF (only applies to USA-market):

- Volvo Construction Equipment: 1-877-823-1111 (office hours)
- www.volvoce.com (outside of office hours)

For information on ordering AdBlue®/DEF (other markets), contact your local Volvo dealer.

**Actions in case of contact with AdBlue®/DEF:**

- In case of skin contact, rinse thoroughly with water. The fluid may cause irritation of the skin.
- In case of eye contact, rinse thoroughly for several minutes. If needed, contact a doctor for advice.
- In case of inhalation, breathe fresh air and contact a doctor if needed.
- If swallowed, drink water and contact a doctor.



338 Specifications
Service capacities and change intervals

Service capacities and change intervals

Oil and fluid change, intervals

Please see lubrication and service chart on page 268.

Filter change, intervals

Please see lubrication and service chart on page 268.

Oils and other liquids		EW160E	EW180E
Engine			
Engine incl. filter		25.0 l (6.6 US gal)	25.0 l (6.6 US gal)
Coolant including anti-freeze		33.0 l (8.7 US gal)	33.0 l (8.7 US gal)
AdBlue®/DEF tank		25.0 l (6.6 US gal)	25.0 l (6.6 US gal)
Fuel tank		250 l (66.0 US gal)	290 l (76.6 US gal)
Hydraulic system			
Hydraulic system, complete		260 l (68.7 US gal)	340 l (89.8 US gal)
Hydraulic system, changing volume		145 l (38.3 US gal)	185 l (48.9 US gal)
Hydraulic oil tank		123 l (32.5 US gal)	165 l (43.6 US gal)
Axles			
Front axle, standard	Differential	9.5 l (2.5 US gal)	9.5 l (2.5 US gal)
	Hub (Planetary gear)	2.5 l (0.7 US gal)	2.5 l (0.7 US gal)
	Oil quantity total	14.5 l (3.8 US gal)	14.5 l (3.8 US gal)
Front axle, wide (optional equipment)	Differential	10.5 l (2.8 US gal)	10.5 l (2.8 US gal)
	Hub (Planetary gear)	2.5 l (0.7 US gal)	2.5 l (0.7 US gal)
	Oil quantity total	15.5 l (4.1 US gal)	15.5 l (4.1 US gal)
Rear axle, standard	Differential	12.5 l (3.3 US gal)	12.5 l (3.3 US gal)
	Hub (Planetary gear)	2.5 l (0.7 US gal)	2.5 l (0.7 US gal)
	Oil quantity total	17.5 l (4.6 US gal)	17.5 l (4.6 US gal)
Rear axle, wide (optional equipment)	Differential	14.0 l (3.7 US gal)	14.0 l (3.7 US gal)
	Hub (Planetary gear)	2.5 l (0.7 US gal)	2.5 l (0.7 US gal)
	Oil quantity total	19.0 l (5.0 US gal)	19.0 l (5.0 US gal)
Travel gear box / Swing gear box			
Travel gear box		2.5 l (0.7 US gal)	2.5 l (0.7 US gal)
Swing gear box		—	7.0 l (1.9 US gal)



Engine

EW160E	
Designation	D6J
Type	Four stroke diesel engine with direct injection and electronic control, water cooled, turbo charged with charge air cooler
Output	115 kW / 156 PS / 154 hp
Engine speed	1900 rpm (31.7 r/s)
Idling speed, low	800 rpm (13.3 r/s)
Fuel injection system	Common rail
Number of cylinders	6, vertical in line
Number of valves	24
Cylinder displacement	5.7 l (348 in ³)
Bore	98 mm (3.86 in)
Stroke	126 mm (4.96 in)
Compression ratio	18.4:1
Rational direction	Facing flywheel, anti clockwise
Injection sequence	1-5-3-6-2-4
Maximum torque	716 Nm (528 lbf ft) at 1400 rpm (23.3 r/s)

EW180E	
Designation	D6J
Type	Four stroke diesel engine with direct injection and electronic control, water cooled, turbo charged with charge air cooler
Output	129 kW / 175 PS / 173 hp
Engine speed	1800 rpm (30 r/s)
Idling speed, low	800 rpm (13.3 r/s)
Fuel injection system	Common rail
Number of cylinders	6, vertical in line
Number of valves	24
Cylinder displacement	5.7 l (348 in ³)
Bore	98 mm (3.86 in)
Stroke	126 mm (4.96 in)
Compression ratio	18.4:1
Rational direction	Facing flywheel, anti clockwise
Injection sequence	1-5-3-6-2-4
Maximum torque	850 Nm (630 lbf ft) at 1350 rpm (22.5 r/s)



340 Specifications
Electrical system

Electrical system

System voltage	24 V
Battery	12 V x 2 (connected in series)
Capacity	140 Ah/battery
Alternator	
Current rating	120 A
Voltage	24 V
Output	110 A
Type	Body grounded
Starter motor	
Voltage	24 V
Output	5.5 kW (7.5 hp)

Bulbs		
Position	Socket	Output
Headlights, front	H4	24 V, 75/70 W
Direction indicators, front	BA15s	24 V, 21 W
Parking lights, front	BA9s	24 V, 4 W
Tail light / Brake light Reverse light Direction indicators, rear	LED	
Interior lighting	BA15s	24 V, 10 W
Interior lighting spotlight	BA15s	24 V, 5 W
Working lights	H3	24 V, 70 W
Working lights (optional equipment)	LED	
Licence plate	LED	
Rotating beacon (optional equipment)	LED	



Relays and fuses

NOTE!

Turn off the electric power with the battery disconnect switch before starting any work.

Relays and fuses

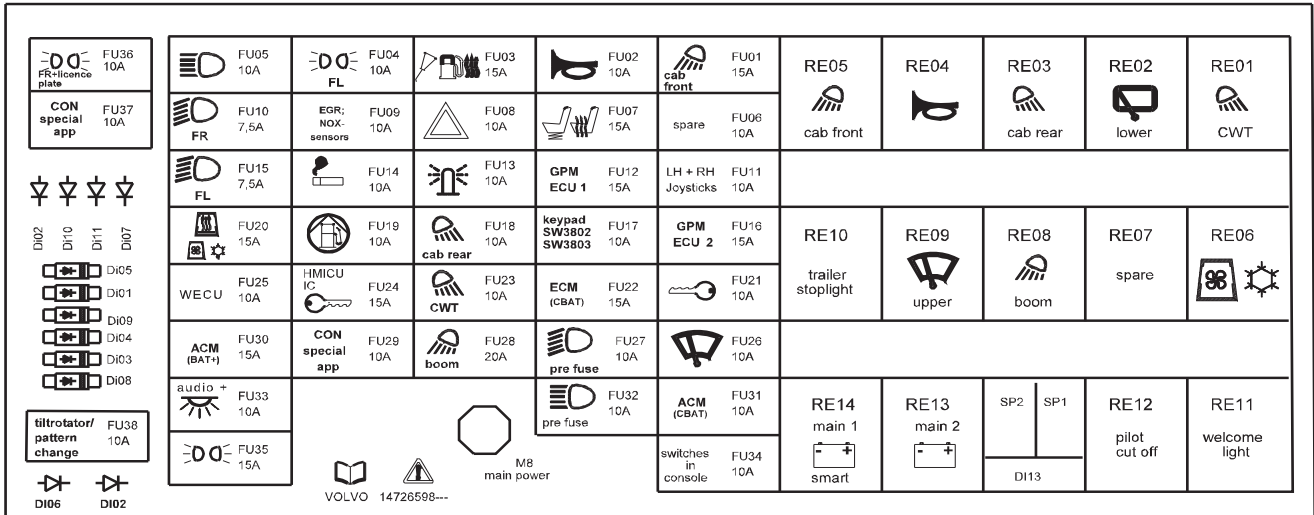

V1186421

Electrical distribution box - Decal

NOTE!

The following list contains all relays and fuses, some parts and functions are optional equipment.

Relays	
Marking	Description
RE01	Relay working lights, counterweight
RE02	Windscreen wiper relay, lower
RE03	Relay working lights, cab rear
RE04	Horn relay
RE05	Relay working lights, cab front
RE06	Diesel heater and air conditioning relay
RE07	Spare
RE08	Relay working lights, boom
RE09	Windscreen wiper relay, upper
RE10 / SP	Trailer stop light relay
RE11	Relay Remote welcome lights
RE12	Pilot pressure control relay (control lockout)
RE13	Main relay 2 (15)
RE14	Main relay 1 (CBAT)
RE2501	Preheating relay, induction air
RE3533	Remote welcome lights timer relay
RF3601	Flasher relay



342 Specifications
Electrical system

Fuses in distribution box		
Fuse	Designation	Capacity (Ampere)
FU01	Fuse, working lights cab front	15 A
FU02	Fuse, horn	10 A
FU03	Fuse, fuel warmer and automatic lubrication system	15 A
FU04	Fuse, position light left	10 A
FU05	Fuse, high beams	10 A
FU06	Fuse, Spare	10 A
FU07	Fuse, operator seat	15 A
FU08	Fuse, flasher relay and direction indicators	10 A
FU09	Fuse, EGR actuator and Nox sensors	10 A
FU10	Fuse, low beam right	7.5 A
FU11	Fuse, 24V joysticks, X1 pedal, SE6404	10 A
FU12	Fuse, GPMECU1 power	15 A
FU13	Fuse, rotating beacon	10 A
FU14	Fuse, cigarette lighter	10 A
FU15	Fuse, low beam left	7.5 A
FU16	Fuse, GPMECU2 power	15 A
FU17	Fuse, power supply key pad, Volvo Co-Pilot	10 A
FU18	Fuse, working lights cab rear	10 A
FU19	Fuse, fuel filler pump	10 A
FU20	Fuse, diesel heater and air conditioning, Remote welcome lights, Volvo Co-Pilot	20 A
FU21	Fuse, hydraulic system, control lockout lever	10 A
FU22	Fuse, ECM power	15 A
FU23	Fuse, working light, counterweight	10 A
FU24	Fuse, ignition key, IC (Instrument Cluster), HMICU	15 A
FU25	Fuse, CareTrack W-ECU	10 A
FU26	Fuse, windscreen wiper	10 A
FU27	Fuse, low beam	10 A
FU28	Fuse, working lights boom	20 A
FU29	Fuse, connector special applications 2	10 A
FU30	Fuse, ACM power (Battery +)	15 A
FU31	Fuse, ACM / HMICU after ignition key	10 A
FU32	Fuse, wiper and horn	10 A
FU33	Fuse, interior light, voltage converter, radio	10 A
FU34	Fuse, 24V power supply switches	10 A
FU35	Fuse, head lights, stop light trailer	15 A
FU36	Fuse, position light right, license plate	10 A
FU37	Fuse, connector special applications 1	10 A
FU38	Fuse, tiltrotator, control pattern changer	10 A
FU90	Fuse, Volvo Co-Pilot	5 A
FU99	Fuse, Volvo Co-Pilot	7,5 A



Specifications
Electrical system **343**

Fuses close to the batteries		
Fuse	Designation	Capacity (Ampere)
FC02	Main fuse for Electric distribution box	80 A
FC03	Fuse, auxiliary heater	20 A

Fuse on the engine		
Fuse	Designation	Capacity (Ampere)
FU2501	Fuse, Preheater induction air	150 A



344 Specifications
Wheels

Wheels

Tyre sizes and pressures

Valid for serial numbers		
Model version	Serial number start	Serial number stop
EW160E	Konz 322001	Konz 322332
EW180E	Konz 322001	Konz 322116

Model	Tyres	Size	Tyre pressure	Rim
Available				
EW160/180E	Bridgestone FGF (twin mounted)	10.00-20 16PR	7.5 bar (109 psi)	Rim 7.5-20 HD
EW160/180E	Mitas NB38 (twin mounted)	10.00-20 16PR	7.5 bar (109 psi)	Rim 7.5-20 HD
EW160/180E	Mitas EM22 TT (twin mounted)	10.00-20 16PR	7.5 bar (109 psi)	Rim 7.5-20 HD
EW160/180E	Nokian Armor Gard 2 (T445649) (twin mounted)	10.00-20 16PR	7.5 bar (109 psi)	Rim 7.5-20 HD
EW160/180E	Nokian Armor Gard (twin mounted)	11.00-20 16PR	7.5 bar (109 psi)	Rim 8.0-20 HD
EW160/180E	Michelin XF (single mounted)	18R 19.5xTyp XF / 445- 70R19,55 173A8-180A2 TLXF	7.5 bar (109 psi)	Rim 19.5-14
EW160/180E	Alliance Flotation (ATG) (single mounted)	620/40 R22.5	169A8: 6.5 bar (94 psi) 171A8: 7 bar (102 psi)	Rim 22.5xAG20.00
EW160E (not for EW160E HEC and EW180E)	Nokian Excavator SF TL (T445604) (single mounted)	600/50-22,5 24PR	173A8: 6 bar (87 psi)	Rim 22.5xAG20.00
EW160/180E	Trelleborg T-900 (twin mounted)	10.00-20 16PR	9 bar (131 psi)	Rim 7.5-20 HD
EW160/180E	Solideal MAGNUM Full Solid (twin mounted)	10.00-20	full solid	Rim 7.5-20 HD
EW160/180E	Solideal MAGNUM Full Solid (twin mounted)	11.00-20	full solid	Rim 8.0-20 HD
EW160E (not for EW160E HEC and EW180E)	Bandenmarkt Grader (twin mounted)	315/70 R22,5	<19t: 8.5 bar (123 psi)	Rim 22.5x7.50
EW160E (not for EW160E HEC and EW180E)	Bandenmarkt Excavator (twin mounted)	315/70 R22,5	<19t: 8.5 bar (123 psi)	Rim 22.5x7.50
EW160E (not for EW160E HEC and EW180E)	HBI Delocora (twin mounted)	315/70 R22,5	<19t: 8.5 bar (123 psi)	Rim 22.5x7.50
EW160E HEC/ EW180E only	Bandenmarkt Grader (twin mounted)	315/70 R22,5	>19t-21t: 9.5 bar (138 psi)	Rim 22.5x7.50 (Reinforced)



Specifications
Wheels 345

Model	Tyres	Size	Tyre pressure	Rim
Available				
EW160E HEC/ EW180E only	Bandenmarkt Excavator (twin mounted)	315/70 R22,5	>19t-21t: 9.5 bar (138 psi)	Rim 22.5x7.50 (Reinforced)
EW160E HEC/ EW180E only	HBI Delocora (twin mounted)	315/70 R22,5	>19t-21t: 9.5 bar (138 psi)	Rim 22.5x7.50 (Reinforced)

Model	Tyres	Size	Tyre pressure	Rim
Not available but can be used				
EW160/180E	Bridgestone FG (twin mounted)	10.00-20 14PR	7 bar (102 psi)	Rim 7.5-20 HD
EW160/180E	Mitas NB38 (twin mounted)	11.00-20 16PR	7.25 bar (105 psi)	Rim 8.0-20 HD
EW160/180E	Alliance Flotation (ATG) (single mounted)	18PR 600/40- 22.5 18PR	6 bar (87 psi)	Rim 22.5xAG20.00
EW160/180E	Galaxy Tires (ATG) EX-1 (twin mounted)	10.00-20 16PR	7 bar (102 psi)	Rim 7.5-20 HD
EW160/180E	Bridgestone FG (twin mounted)	11.00-20 16PR	7 bar (102 psi)	Rim 8.0-20 HD
EW160/180E	Bandenmarkt Excavator (twin mounted)	315/80 R22,5	<19t: 8.5 bar (123 psi) >19t-21t: 9.5 bar (138 psi)	Rim 22.5x7.50
EW160/180E	Bandenmarkt Grader (twin mounted)	315/80 R22,5	<19t: 8.5 bar (123 psi) >19t-21t: 9.5 bar (138 psi)	Rim 22.5x7.50
EW160E (not for EW160E HEC >20km/h (12.43 mph) and EW180E)	NOKIAN TRS LS-2 Excavator SF TL (single mounted)	600/50-22,5 20PR	4.2 bar (65 psi)	Rim 22.5xAG20.00
EW160/180E	Nokian Armor Gard 1 (twin mounted)	10.00-20 16PR	7.5 bar (109 psi)	Rim 7.5-20 HD

Tyre sizes and pressures

Valid for serial numbers		
Model version	Serial number start	Serial number stop
EW160E	Konz 322333	Konz 322999
EW180E	Konz 322117	Konz 322999

Model	Tyres	Size	Tyre pressure	Rim
Available				
EW160/180E	Bridgestone FGF (twin mounted)	10.00-20 16PR	7.5 bar (109 psi)	Rim 7.5-20 HD
EW160/180E	Mitas NB38 (twin mounted)	10.00-20 16PR	7.5 bar (109 psi)	Rim 7.5-20 HD
EW160/180E	Mitas EM22 TT (twin mounted)	10.00-20 16PR	7.5 bar (109 psi)	Rim 7.5-20 HD
EW160/180E	Nokian Armor Gard 2 (T445649) (twin mounted)	10.00-20 16PR	7.5 bar (109 psi)	Rim 7.5-20 HD
EW160/180E	Nokian Armor Gard (twin mounted)	11.00-20 16PR	7.5 bar (109 psi)	Rim 8.0-20 HD



346 **Specifications**
Wheels

Model	Tyres	Size	Tyre pressure	Rim
Available				
EW160/180E	Michelin XF (single mounted)	18R 19.5xTyp XF / 445-70R19,55 173A8-180A2 TLXF	7.5 bar (109 psi)	Rim 19.5-14
EW160/180E	Alliance Flotation (ATG) (single mounted)	620/40 R22.5	169A8: 6.5 bar (94 psi) 171A8: 7 bar (102 psi)	Rim 22.5xAG20.00
EW160E (not for EW160E HEC and EW180E)	Nokian Excavator SF TL (T445604) (single mounted)	600/50-22,5 24PR	173A8: 6 bar (87 psi)	Rim 22.5xAG20.00
EW160/180E	Trelleborg T-900 (twin mounted)	10.00-20 16PR	9 bar (131 psi)	Rim 7.5-20 HD
EW160/180E	Solideal MAGNUM Full Solid (twin mounted)	10.00-20	full solid	Rim 7.5-20 HD
EW160/180E	Solideal MAGNUM Full Solid (twin mounted)	11.00-20	full solid	Rim 8.0-20 HD
EW160E (not for EW160E HEC and EW180E)	HBI Delocora (twin mounted)	315/70 R22,5	<19t: 8.5 bar (123 psi)	Rim 22.5x7.50
EW160E HEC/ EW180E only	HBI Delocora (twin mounted)	315/70 R22,5	>19t-21t: 9.5 bar (138 psi)	Rim 22.5x7.50 (Reinforced)

Model	Tyres	Size	Tyre pressure	Rim
Not available but can be used				
EW160/180E	Bridgestone FG (twin mounted)	10.00-20 14PR	7 bar (102 psi)	Rim 7.5-20 HD
EW160/180E	Mitas NB38 (twin mounted)	11.00-20 16PR	7.25 bar (105 psi)	Rim 8.0-20 HD
EW160/180E	Alliance Flotation (ATG) (single mounted)	18PR 600/40-22.5 18PR	6 bar (87 psi)	Rim 22.5xAG20.00
EW160/180E	Galaxy Tires (ATG) EX-1 (twin mounted)	10.00-20 16PR	7 bar (102 psi)	Rim 7.5-20 HD
EW160/180E	Bridgestone FG (twin mounted)	11.00-20 16PR	7 bar (102 psi)	Rim 8.0-20 HD
EW160/180E	Bandenmarkt Excavator (twin mounted)	315/80 R22,5	<19t: 8.5 bar (123 psi) >19t-21t: 9.5 bar (138 psi)	Rim 22.5x7.50
EW160/180E	Bandenmarkt Grader (twin mounted)	315/80 R22,5	<19t: 8.5 bar (123 psi) >19t-21t: 9.5 bar (138 psi)	Rim 22.5x7.50
EW160E (not for EW160E HEC >20km/h (12.43 mph) and EW180E)	NOKIAN TRS LS-2 Excavator SF TL (single mounted)	600/50-22,5 20PR	4.2 bar (65 psi)	Rim 22.5xAG20.00
EW160/180E	Nokian Armor Gard 1 (twin mounted)	10.00-20 16PR	7.5 bar (109 psi)	Rim 7.5-20 HD



Wheel nuts, tightening torque

Wheel nuts, tightening torque	500 Nm +/- 25 Nm (369 lbf ft +/- 18.45 lbf ft)
-------------------------------	--

Cab

The cab is fitted on rubber elements, is insulated and has a flat floor with rubber mat.

Tested and approved as a protective cab and meets standards according to ISO 12117-2:2008 (ROPS).



As optional equipment the cab can be provided with a protective roof approved according to FOPS regulations (ISO 3449/SAE J231).

Operator seat

The operator seat meets the criteria of EN ISO 7096.

Upholstery	Fire resistant
Lap type seat belt	Yes
Adjustment to operator weight	40–130 kg (88–287 lb)

Refrigerant



R134a: X.XX kg
GWP: X.XXXt CO₂-eq

(BG) Съдържа флуорис съдържащи парникови газове • (CS) Obsahuje fluo rovanéskéni kové plyny • (DA) Indeholder fluorholdige drivhugasser
 (DE) Enthält fluore rie Treibhausgase • (ET) sisaldab fluortud kasvuhoonegase • (EL) Περιέχει φθοριούχα αέρια του θερμοκηπίου • (EN) Contains fluorinated greenhouse gases • (ES) Contiene gases fluo rados de e factu i nvernade ro • (FI) Sisältää fluo rattuja kasvihuonekaasuja • (FR) Contient des gaz à ef fet de ser re fluo rés • (HR) Sadržava fluo rane staklenič ke plino ve • (HU) Fluo rtartalmú ü veghőzártsású gázokat ta rtalmaz • (IT) Contiene gas fluoro rati a ef fetto ser ra • (LT) sudėtyje y ra fluo rinti šiltnamio e fektą su keliančią dujų • (LV) Satur fluo rttas silumit' ce fektā gāzes • (MT) Fih gasijiet fluoro rati b'ef fett ta' ser ra • (NL) B evat gefluo reerde b roelkasgassen • (PL) Zawiera fluo rowane gazy cieplarniane • (PT) Contém gases fluo rados com e feito de estu fa • (RO) Contine gaze fluoro rate cu e fact de se ra • (SI) Obsahuje fluo rovanéskéni kové plyny • (SL) vsebuje fluo rni rane toplog redne pline • (SV) Innehåller fluo rerade växthusgaser
xxxxxxx

V1180180

Type	Quantity	GWP(a)
R-134a	0.80 kg	1.144 tonne CO ₂ -eq

a) Global warming potential (GWP) is a measure of how much heat a gas traps in the atmosphere relative to that of carbon dioxide (CO₂). GWP is calculated in terms of the 100-year warming potential of 1 kg of a greenhouse gas relative to 1 kg of CO₂.



Noise and vibrations

Hand-arm vibrations

Emission of hand-arm vibration during real operating conditions at its intended use is less than 2.5 m/s² RMS (root mean square) acceleration according to ISO 8041.

Whole-body vibrations

Emission of whole-body vibration during real operating conditions at its intended use is less than 0.5 m/s² RMS (root mean square) acceleration according to ISO 8041 for excavating.

NOTE!

This whole-body vibration emission value was determined at particular operating and terrain conditions and is therefore not representative for all the various conditions in accordance with the intended use of the machine and should not alone be used to determine the whole-body vibration exposure to the operator using the machine. For this purpose the information in ISO/CEN Technical Report (under development) is recommended.

To ensure that the whole-body vibration emission during machine use is kept to a minimum, see the guidelines page 193.

Sound information

Sound pressure level (L_{pA}) at operator position (Measurement according to ISO 6396)	70 dB (EW160E) 70 dB (EW180E)
Sound power level (L_{WA}) around the machine (Measurement according to 2000/14/ EC with applicable appendices and measuring method according to ISO 6395)	100 dB (EW160E) 101 dB (EW180E) 102 dB (EW180E Tropical cooling)





350 Specifications
Hydraulic system

Hydraulic system

	EW160E	EW180E
Working pump	Axial piston pump	
Max. flow	254 l/min (67.1 US gal/min)	399 l/min (105.4 US gal/min)
Brake + steering pump	Gear pump	
Max. flow	43 l/min. (11.4 US gal/min)	47 l/min. (12.4 US gal/min)
Servo pump	Gear pump	
Max. flow	14 l/min. (3.7 US gal/min)	15 l/min. (4 US gal/min)
Fan pump (option reversible fan)	Axial piston pump	
Max. flow	49 l/min. (12.9 US gal/min)	53 l/min. (14 US gal/min)
System pressure		
Max. pressure	34 MPa 340 bar (4931 psi)	
Max. pressure with Power Boost	37.5 MPa 375 bar (5439 psi)	
Servo pressure	3.4 MPa +0.2 34 +2 bar (493 +14.5 psi)	



Specifications
Hydraulic system **351**

Option X1 Pressure and flow	EW160E	EW180E
Flow (adjustable)	0 – 240 l/min. (0 – 63.4 US gal/min)	0 – 250 l/min. (0 – 66 US gal/min)
Pressure (adjustable)	10 – 37.5 MPa 100–375 bar 1450 – 5439 psi	

Option X3 Pressure and flow	EW160E	EW180E
Flow (adjustable)	0 – 70 l/min. (0 – 18.5 US gal/min)	
Pressure (adjustable)	23 ±1 MPa 230 ±10 bar 3336 ±145 psi	

Port specifications (Dipper arm front)	EW160E	EW180E
Grab piping	SAE 3/4" 6000 PSI	
X1	1" SAE flange 6000 PSI	
X3	3/4-16 UNF (port connection)	
Slope piping	9/16-18 ORFS (port connection)	
Hammer return	1" SAE flange 6000 PSI	

For the port locations, see 99



352 Specifications
Machine weights

Machine weights

Applies to models: EW160E

EW160E

EW160E with	Counterweight	Total machine weight incl. stabiliser blade front and stabiliser legs rear	Total machine weight incl. stabiliser blade rear	Total machine weight incl. stabiliser legs front and rear
5.0 m (16 ft 4.9 in) monoblock boom 2.45 m (8 ft 0.5 in) dipper arm Attachment quick coupler S6 530 kg / 750 l bucket	standard	17270 kg (38074 lb)	16200 kg (35715 lb)	17520 kg (38625 lb)
	heavy	17670 kg (38956 lb)	16600 kg (36597 lb)	17920 kg (39507 lb)
5.1 m (16 ft 8.8 in) two-piece boom 2.45 m (8 ft 0.5 in) dipper arm Attachment quick coupler S6 530 kg / 750 l bucket	standard	17610 kg (38823 lb)	16540 kg (36464 lb)	17860 kg (39375 lb)
	heavy	18010 kg (39705 lb)	16940 kg (37346 lb)	18260 kg (40256 lb)

EW160E HEC with	Counterweight	Total machine weight incl. stabiliser blade front and stabiliser legs rear	Total machine weight incl. stabiliser blade rear	Total machine weight incl. stabiliser legs front and rear
5.0 m (16 ft 4.9 in) monoblock boom 2.45 m (8 ft 0.5 in) dipper arm Attachment quick coupler S6 530 kg / 750 l bucket	standard	18200 kg (40124 lb)	17130 kg (37765 lb)	18450 kg (40675 lb)
	heavy	18600 kg (41006 lb)	17530 kg (38647 lb)	18850 kg (41557 lb)
5.1 m (16 ft 8.8 in) two-piece boom 2.45 m (8 ft 0.5 in) dipper arm Attachment quick coupler S6 530 kg / 750 l bucket	standard	18540 kg (40874 lb)	17470 kg (38515 lb)	18790 kg (41425 lb)
	heavy	18940 kg (41756 lb)	17870 kg (39397 lb)	19190 kg (42307 lb)

Applies to models: EW180E

EW180E

EW180E with	Total machine weight incl. stabiliser blade front and stabiliser legs rear	Total machine weight incl. stabiliser blade rear	Total machine weight incl. stabiliser legs front and rear
5.2 m (17 ft 0.7 in) monoblock boom 2.45 m (8 ft 0.5 in) dipper arm Attachment quick coupler S1 590 kg / 870 l bucket	19900 kg (43872 lb)	18700 kg (41226 lb)	20220 kg (44577 lb)
5.5 m (18 ft 0.5 in) two-piece boom 2.45 m (8 ft 0.5 in) dipper arm Attachment quick coupler S1 590 kg / 870 l bucket	20500 kg (45195 lb)	19300 kg (42549 lb)	20800 kg (45856 lb)



Dimensions

EW160E

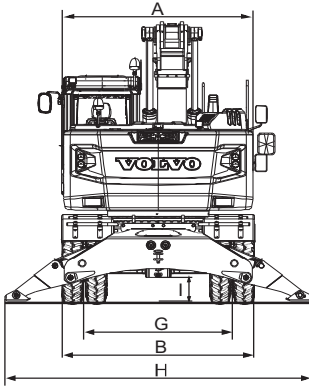

EW160E

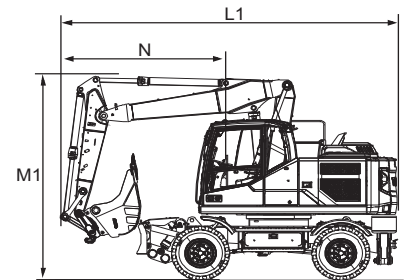
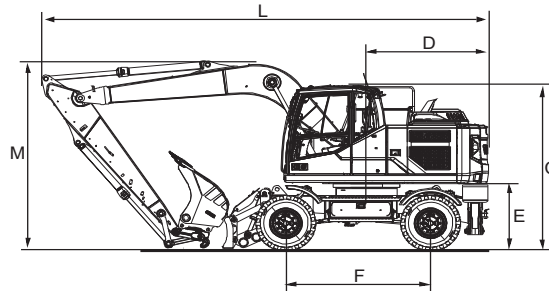

V1150852

Description	EW160E
A. Overall width of superstructure	2514 mm (8 ft 3 in)
B. Overall width of blade	2540 mm (8 ft 4 in) optional: 2750 mm (9 ft 0.3 in)
C. Overall height of cab	3143 mm (10 ft 3.7 in)
D. Tail slew radius (standard and heavy counterweight)	2189 mm (7 ft 2.2 in)
E. Counterweight clearance	1243 mm (4 ft 0.9 in)
F. Wheel base	2600 mm (8 ft 6.4 in)
G. Tread	1942 mm (6 ft 4.5 in) optional: 2110 mm (6 ft 11.1 in)
H. Stabiliser blade width, down (front or rear)	3999 mm (13 ft 1.4 in)
I. Min. ground clearance	326 mm (1 ft 0.8 in)

Monoblock boom	5.0 m (16 ft 4.9 in)				
Dipper arm	2.0 m (6 ft 6.7 in)	2.45 m (8 ft 0.5 in)	2.6 m (8 ft 6.4 in)	3.1 m (10 ft 2 in)	2.95 m * (9 ft 8.1 in *)
L. Overall length (standard and heavy counterweight)	8224 mm (26 ft 11.8 in)	8242 mm (27 ft 0.5 in)	8237 mm (27 ft 0.3 in)	8025 mm (26 ft 3.9 in)	8245 mm ** (27 ft 0.6 in **)
M. Overall height of boom	3072 mm (10 ft 0.9 in)	3072 mm (10 ft 0.9 in)	3165 mm (10 ft 4.6 in)	3608 mm (11 ft 10.1 in)	3149 mm ** (10 ft 4 in **)

Two-piece boom	5.1 m (16 ft 8.8 in)				
Dipper arm	2.0 m (6 ft 6.7 in)	2.45 m (8 ft 0.5 in)	2.6 m (8 ft 6.4 in)	3.1 m (10 ft 2 in)	2.95 m * (9 ft 8.1 in *)
L. Overall length (standard and heavy counterweight)	8303 mm (27 ft 2.9 in)	8347 mm (27 ft 4.6 in)	8347 mm (27 ft 4.6 in)	8178 mm (26 ft 10 in)	8340 mm ** (27 ft 4.4 in **)
M. Overall height of boom	2894 mm (9 ft 5.9 in)	2838 mm (9 ft 3.7 in)	2887 mm (9 ft 5.7 in)	3332 mm (10 ft 11.2 in)	2954 mm ** (9 ft 8.3 in **)
L1. Overall length (standard and heavy counterweight)	6232 mm (20 ft 5.4 in)	6306 mm (20 ft 8.3 in)	6005 mm ** (19 ft 8.4 in **)	5981 mm ** (19 ft 7.5 in **)	7013 mm *** (23 ft 0.1 in ***)
M1. Overall height of boom	3989 mm (13 ft 1.1 in)	3987 mm (13 ft 1 in)	3937 mm ** (12 ft 11 in **)	3873 mm ** (12 ft 8.5 in **)	3982 mm *** (13 ft 0.8 in ***)
N. Front overhang	3011 mm (9 ft 10.5 in)	3085 mm (10 ft 1.5 in)	2784 mm ** (9 ft 1.6 in **)	2760 mm ** (9 ft 0.7 in **)	3703 mm *** (12 ft 1.8 in ***)



354 **Specifications**
Dimensions

Monoblock offset boom	4.75 m (15 ft 7 in)			
Dipper arm	2.0 m (6 ft 6.7 in)	2.45 m (8 ft 0.5 in)	2.6 m (8 ft 6.4 in)	3.1 m (10 ft 2 in)
L. Overall length (standard and heavy counterweight)	7977 mm (26 ft 2.1 in)	7942 mm (26 ft 0.7 in)	7888 mm (25 ft 10.6 in)	7899 mm ** (25 ft 11 in **)
M. Overall height of boom	2931 mm (9 ft 7.4 in)	3269 mm (10 ft 8.7 in)	3428 mm (11 ft 3 in)	3494 mm ** (11 ft 5.6 in **)

Two-piece offset boom	5.2 m (17 ft 0.7 in)			
Dipper arm	2.0 m (6 ft 6.7 in)	2.45 m (8 ft 0.5 in)	2.6 m (8 ft 6.4 in)	3.1 m (10 ft 2 in)
L. Overall length (standard and heavy counterweight)	8426 mm (27 ft 7.7 in)	8403 mm (27 ft 6.8 in)	8382 mm (27 ft 6 in)	8259 mm (27 ft 1.2 in)
M. Overall height of boom	2912 mm (9 ft 6.5 in)	3058 mm (10 ft 0.4 in)	3117 mm (10 ft 2.7 in)	3435 mm (11 ft 3.2 in)
L1. Overall length (standard and heavy counterweight)	6241 mm (20 ft 5.7 in)	6255 mm (20 ft 6.3 in)	6284 mm (20 ft 7.4 in)	6144 mm ** (20 ft 1.9 in **)
M1. Overall height of boom	3932 mm (12 ft 10.8 in)	3932 mm (12 ft 10.8 in)	4000 mm (13 ft 1.5 in)	3978 mm ** (13 ft 0.6 in **)
N. Front overhang	3021 mm (9 ft 10.9 in)	3034 mm (9 ft 11.5 in)	3063 mm (10 ft 0.6 in)	2923 mm ** (9 ft 7.1 in **)

* with dipper arm for grab

** without bucket

*** with clamshell

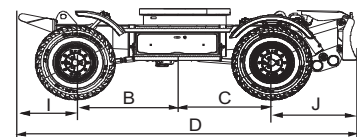
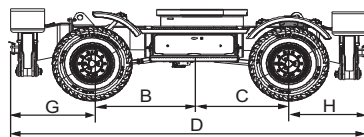
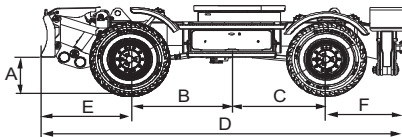

V1150853

EW160E Undercarriage

Description	EW160E Undercarriage
A. Ground clearance blade in upper position	517 mm (1 ft 8.4 in)
B. Center to front wheel	1450 mm (4 ft 9.1 in)
C. Center to rear wheel	1150 mm (3 ft 9.3 in)
Blade front and outrigger rear	
D. Width front to rear	4804 mm (15 ft 9.1 in)
E. Blade to wheel	1178 mm (3 ft 10.4 in)
F. Stabiliser to wheel	1027 mm (3 ft 4.4 in)
Outrigger front and rear	
D. Width front to rear	4709 mm (15 ft 5.4 in)
G. Stabiliser to wheel	1082 mm (3 ft 6.6 in)
H. Stabiliser to wheel	1027 mm (3 ft 4.4 in)
Blade rear only	
D. Width front to rear	4473 mm (14 ft 8.1 in)
I. Front to wheel	750 mm (2 ft 5.5 in)
J. Blade to wheel	1123 mm (3 ft 8.2 in)



356 Specifications
Dimensions

EW160E HEC

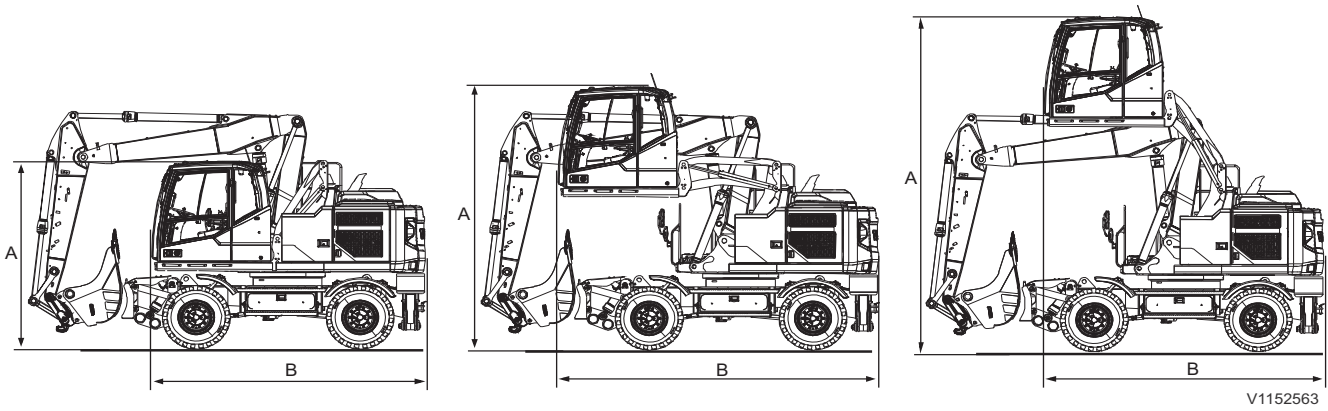

V1152563

EW160E HEC

Description	Cabin in lowest position	Cabin in middle position	Cabin in highest position
A. Overall high of cabin roof	3147 mm (10 ft 3.9 in)	4427 mm (14 ft 6.3 in)	5646 mm (18 ft 6.3 in)
B. Overall length of superstructure	4348 mm (14 ft 3.2 in)	5089 mm (16 ft 8.4 in)	4441 mm (14 ft 6.8 in)



EW180E

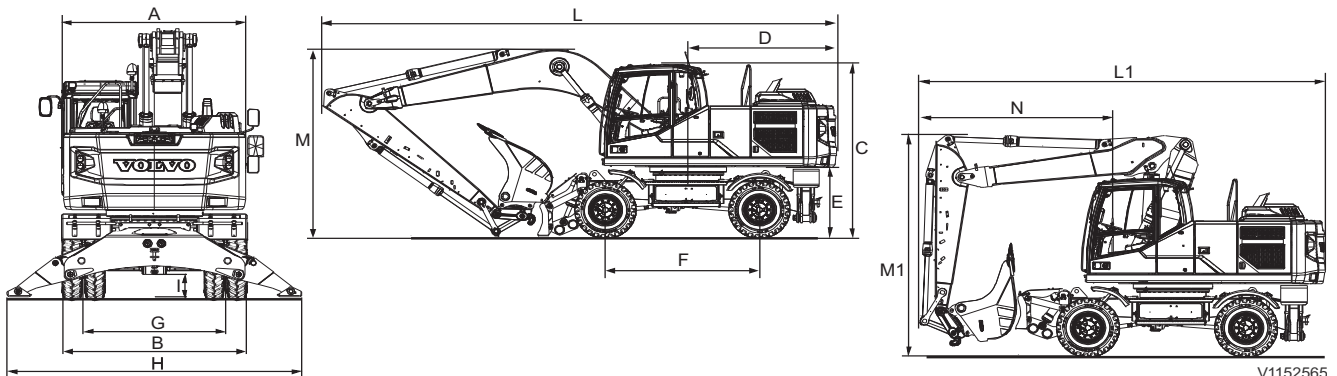

EW180E

Description	
A. Overall width of superstructure	2490 mm (8 ft 2 in)
B. Overall width	2540 mm (8 ft 4 in) optional: 2750 mm (9 ft 0.3 in)
C. Overall height of cab	3173 mm (10 ft 4.9 in)
D. Tail slew radius	2549 mm (8 ft 4.4 in)
E. Counterweight clearance	1273 mm (4 ft 2.1 in)
F. Wheel base	2650 mm (8 ft 8.3 in)
G. Tread	1942 mm (6 ft 4.5 in) optional: 2110 mm (6 ft 11.1 in)
H. Stabiliser blade width, down (front or rear)	4032 mm (13 ft 2.7 in)
I. Min. ground clearance	326 mm (1 ft 0.8 in)

Monoblock boom	5.2 m (17 ft 0.7 in)			
Dipper arm	2.45 m (8 ft 0.5 in)	2.6 m (8 ft 6.4 in)	3.0 m (9 ft 10.1 in)	3.2 m * (10 ft 6 in *)
L. Overall length	8872 mm (29 ft 1.3 in)	8870 mm (29 ft 1.2 in)	8843 mm (29 ft 0.2 in)	8735 mm ** (28 ft 7.9 in **)
M. Overall height of boom	3163 mm (10 ft 4.5 in)	3116 mm (10 ft 2.7 in)	3440 mm (11 ft 3.4 in)	3662 mm ** (12 ft 0.2 in **)

Two-piece boom	5.5 m (18 ft 0.5 in)			
Dipper arm	2.45 m (8 ft 0.5 in)	2.6 m (8 ft 6.4 in)	3.0 m (9 ft 10.1 in)	3.2 m * (10 ft 6 in *)
L. Overall length	9122 mm (29 ft 11.1 in)	9109 mm (29 ft 10.6 in)	9096 mm (29 ft 10.1 in)	8987 mm ** (29 ft 5.8 in **)
M. Overall height of boom	2963 mm (9 ft 8.7 in)	3022 mm (9 ft 11 in)	3188 mm (10 ft 5.5 in)	3409 mm ** (11 ft 2.2 in **)
L1. Overall length	6792 mm (22 ft 3.4 in)	6763 mm ** (22 ft 2.3 in **)	6786 mm ** (22 ft 3.2 in **)	6748 mm ** (22 ft 1.7 in **)
M1. Overall height of boom	3947 mm (12 ft 11.4 in)	3929 mm ** (12 ft 10.7 in **)	3929 mm ** (12 ft 10.7 in **)	3929 mm ** (12 ft 10.7 in **)
N. Front overhang	3209 mm (10 ft 6.3 in)	3179 mm ** (10 ft 5.2 in **)	3197 mm ** (10 ft 5.9 in **)	3164 mm ** (10 ft 4.6 in **)

* with dipper arm for grab

** without bucket

*** with clamshell

358 Specifications
Dimensions

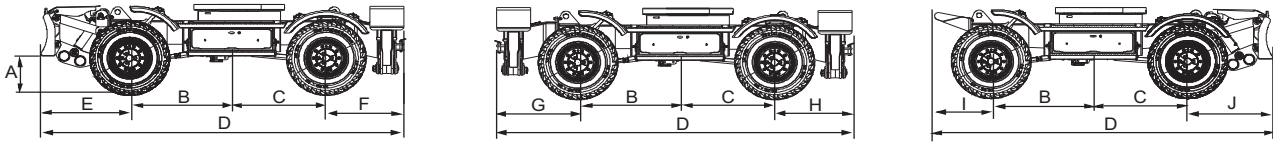

V1152564

EW180E Undercarriage

Description	EW180E Undercarriage
A. Ground clearance blade in upper position	461 mm (1 ft 6.2 in)
B. Center to front wheel	1425 mm (4 ft 8.1 in)
C. Center to rear wheel	1225 mm (4 ft 0.2 in)
Blade front and outrigger rear	
D. Width front to rear	4906 mm (16 ft 1.2 in)
E. Blade to wheel	1213 mm (3 ft 11.8 in)
F. Stabiliser to wheel	1043 mm (3 ft 5.1 in)
Outrigger front and rear	
D. Width front to rear	4821 mm (15 ft 9.8 in)
G. Stabiliser to wheel	1128 mm (3 ft 8.4 in)
H. Stabiliser to wheel	1043 mm (3 ft 5.1 in)
Blade rear only	
D. Width front to rear	4558 mm (14 ft 11.5 in)
I. Front to wheel	780 mm (2 ft 6.7 in)
J. Blade to wheel	1128 mm (3 ft 8.4 in)

Working ranges

EW160E

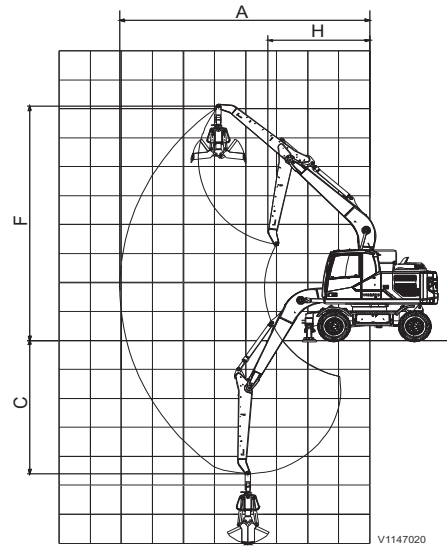
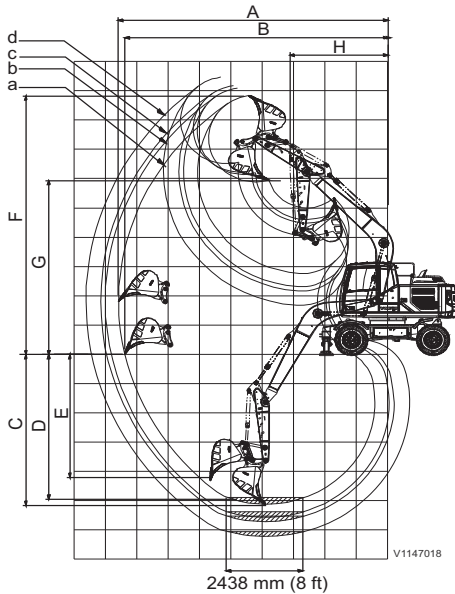

EW160E Monoblock boom	5.0 m (16 ft 4.9 in)				
Quick coupler	S6				-
Bucket	V4_GP				Clamshell
Dipper arm	a 2.0 m (6 ft 6.8 in)	b 2.45 m (8 ft 0.5 in)	c 2.6 m (8 ft 6.4 in)	d 3.1 m (10 ft 2 in)	2.95 m (9 ft 8.1 in*)
A. Max. digging reach	8576 mm (28 ft 1.6 in)	9000 mm (29 ft 6.3 in)	9142 mm (29 ft 11.9 in)	9618 mm (31 ft 6.7 in)	8051 mm (26 ft 5 in)
B. Max. digging reach at ground level	8378 mm (27 ft 5.8 in)	8812 mm (28 ft 10.9 in)	8957 mm (29 ft 4.6 in)	9442 mm (30 ft 11.7 in)	-
C. Max. digging depth	5130 mm (16 ft 10 in)	5580 mm (18 ft 3.7 in)	5730 mm (18 ft 9.6 in)	6230 mm (20 ft 5.3 in)	4585 mm (15 ft 0.5 in)
D. Max. digging depth at 2438 mm (8 ft) level	4908 mm (16 ft 1.2 in)	5386 mm (17 ft 8.1 in)	5544 mm (18 ft 2.3 in)	6065 mm (19 ft 10.8 in)	-
E. Max. vertical wall digging depth	4320 mm (14 ft 2.1 in)	4767 mm (15 ft 7.7 in)	4913 mm (16 ft 1.4 in)	5401 mm (17 ft 8.6 in)	-
F. Max. cutting height	8841 mm (29 ft 0.1 in)	9100 mm (29 ft 10.3 in)	9185 mm (30 ft 1.6 in)	9468 mm (31 ft 0.8 in)	8085 mm (26 ft 6.3 in)
G. Max. dumping height	5888 mm (19 ft 3.8 in)	6143 mm (20 ft 1.9 in)	6228 mm (20 ft 5.2 in)	6511 mm (21 ft 4.3 in)	-
H. Min. front slew radius	3137 mm (10 ft 3.5 in)	3146 mm (10 ft 3.9 in)	3157 mm (10 ft 4.3 in)	3193 mm (10 ft 5.7 in)	3273 mm (10 ft 8.9 in)

360

Specifications
Working ranges

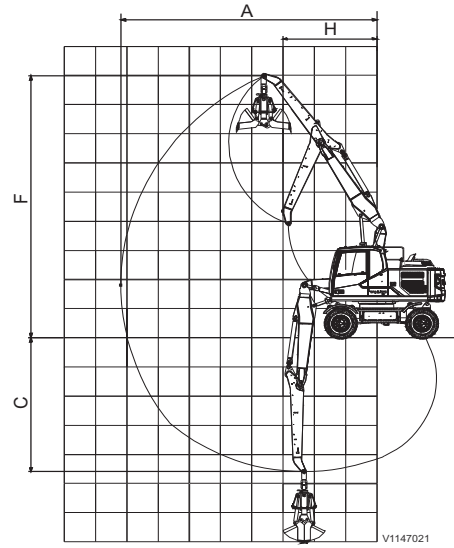
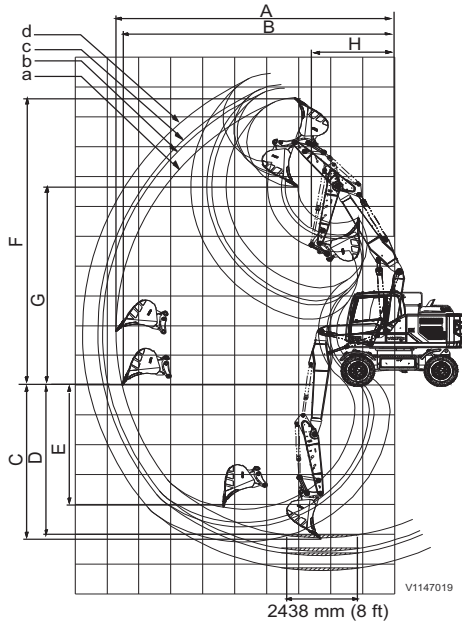

EW160E	5.1 m (16 ft 8.8 in)				
Two-piece boom					
Quick coupler	S6				-
Bucket	V4_GP				Clamshell
Dipper arm	a 2.0 m (6 ft 6.8 in)	b 2.45 m (8 ft 0.5 in)	c 2.6 m (8 ft 6.4 in)	d 3.1 m (10 ft 2 in)	2.95 m (9 ft 8.1 in*)
A. Max. digging reach	8715 mm (28 ft 7.1 in)	9145 mm (30 ft 0 in)	9289 mm (30 ft 5.7 in)	9769 mm (32 ft 0.6 in)	8192 mm (26 ft 10.5 in)
B. Max. digging reach at ground level	8521 mm (27 ft 11.5 in)	8960 mm (29 ft 4.8 in)	9107 mm (29 ft 10.5 in)	9597 mm (31 ft 5.8 in)	-
C. Max. digging depth	5120 mm (16 ft 9.6 in)	5568 mm (18 ft 3.2 in)	5717 mm (18 ft 9.1 in)	6216 mm (20 ft 4.7 in)	4593 mm (15 ft 0.8 in)
D. Max. digging depth at 2438 mm (8 ft) level	5011 mm (16 ft 5.3 in)	5466 mm (17 ft 11.2 in)	5618 mm (18 ft 5.2 in)	6123 mm (20 ft 1.1 in)	-
E. Max. vertical wall digging depth	4078 mm (13 ft 4.6 in)	4547 mm (14 ft 11 in)	4694 mm (15 ft 4.8 in)	5181 mm (16 ft 12 in)	-
F. Max. cutting height	9638 mm (31 ft 7.5 in)	9971 mm (32 ft 8.6 in)	10081 mm (33 ft 0.9 in)	10451 mm (34 ft 3.5 in)	8989 mm (29 ft 5.9 in)
G. Max. dumping height	6668 mm (21 ft 10.5 in)	7000 mm (22 ft 11.6 in)	7111 mm (23 ft 4 in)	7481 mm (24 ft 6.5 in)	-
H. Min. front slew radius	2684 mm (8 ft 9.7 in)	2815 mm (9 ft 2.8 in)	2860 mm (9 ft 4.6 in)	3000 mm (9 ft 10.1 in)	3008 mm (9 ft 10.4 in)



Specifications
Working ranges 361

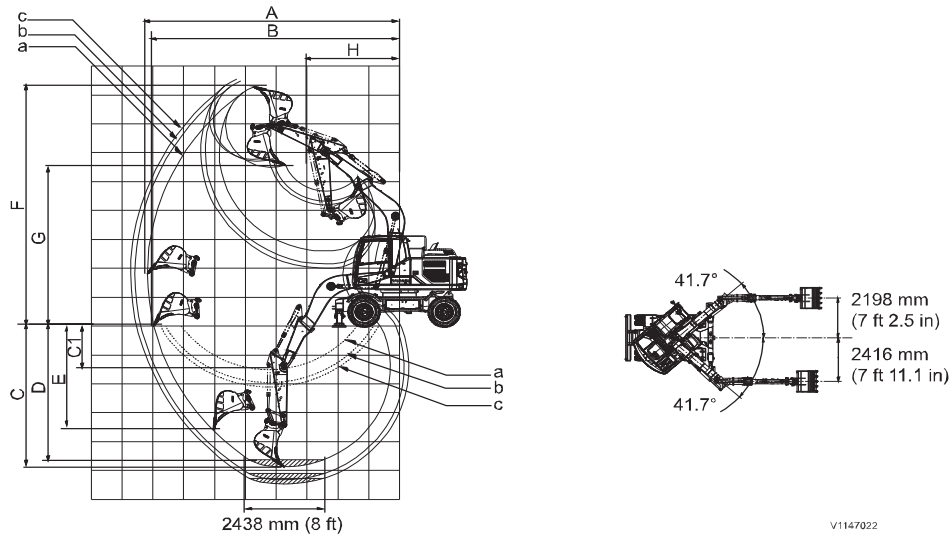

V1147022

EW160E	4.75 m (15 ft 7 in)		
Mono offset boom			
Quick coupler	S60		
Bucket	V4_GP		
Dipper arm	a 2.0 m (6 ft 6.7 in)	b 2.45 m (8 ft 0.5 in)	c 2.6 m (8 ft 6.4 in)
A. Max. digging reach	8174 mm (26 ft 9.8 in)	8583 mm (28 ft 1.9 in)	8720 mm (28 ft 7.3 in)
B. Max. digging reach at ground level	7966 mm (26 ft 1.6 in)	8385 mm (27 ft 6.1 in)	8525 mm (27 ft 11.6 in)
C. Max. digging depth	4874 mm (15 ft 11.9 in)	5324 mm (17 ft 5.6 in)	5474 mm (17 ft 11.5 in)
C1. Max. digging depth at max. attachment offset with vertical trench walls	1505 mm (4 ft 11.3 in)	1955 mm (6 ft 5 in)	2105 mm (6 ft 10.9 in)
D. Max. digging depth at 2438 mm (8 ft) level	4619 mm (15 ft 1.9 in)	5105 mm (16 ft 9 in)	5265 mm (17 ft 3.3 in)
E. Max. vertical wall digging depth	3574 mm (11 ft 8.7 in)	4012 mm (13 ft 2 in)	4153 mm (13 ft 7.5 in)
F. Max. cutting height	8276 mm (27 ft 1.8 in)	8481 mm (27 ft 9.9 in)	8548 mm (28 ft 0.5 in)
G. Max. dumping height	5502 mm (18 ft 0.6 in)	5706 mm (18 ft 8.7 in)	5773 mm (18 ft 11.3 in)
H. Min. front slew radius	2974 mm (9 ft 9.1 in)	2939 mm (9 ft 7.7 in)	2928 mm (9 ft 7.3 in)



362 Specifications
Working ranges

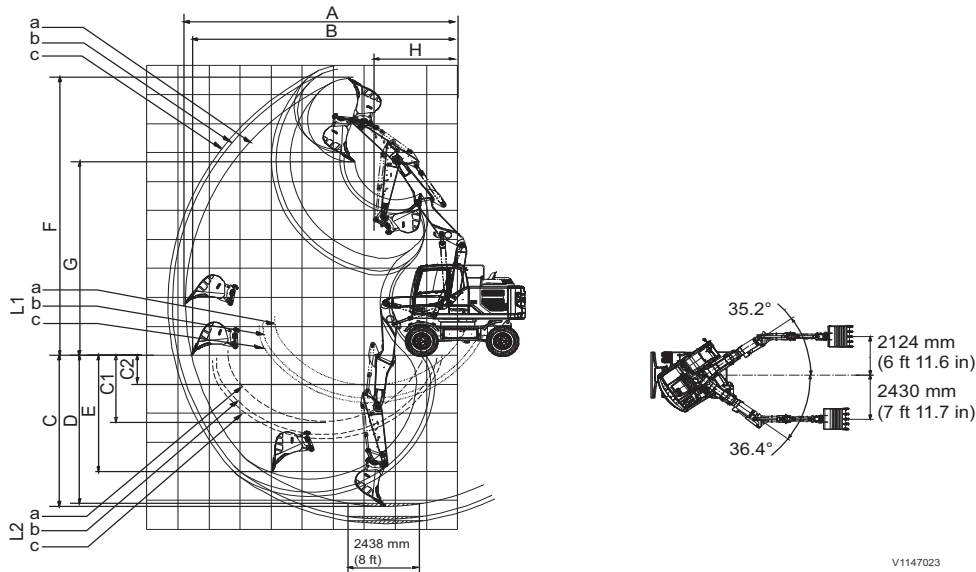

V1147023

L1 – Upper limit / L2 – Lower limit

EW160E	5.2 m (17 ft 0.7 in)		
Two-piece offset boom			
Quick coupler	S60		
Bucket	V4_GP		
Dipper arm	a 2.0 m (6 ft 6.7 in)	b 2.45 m (8 ft 0.5 in)	c 2.6 m (8 ft 6.4 in)
A. Max. digging reach	8755 mm (28 ft 8.7 in)	9180 mm (30 ft 1.4 in)	9322 mm (30 ft 7 in)
B. Max. digging reach at ground level	8562 mm (28 ft 1.1 in)	8996 mm (29 ft 6.2 in)	9141 mm (29 ft 11.9 in)
C. Max. digging depth	5210 mm (17 ft 1.1 in)	5658 mm (18 ft 6.8 in)	5807 mm (19 ft 0.6 in)
C1. Max. digging depth at max. attachment offset with vertical trench walls	2280 mm (7 ft 5.8 in)	2731 mm (8 ft 11.5 in)	2881 mm (9 ft 5.4 in)
C2. Min. digging depth at min. attachment offset with vertical trench walls	1028 mm (3 ft 4.5 in)	1479 mm (4 ft 10.2 in)	1629 mm (5 ft 4.1 in)
D. Max. digging depth at 2438 mm (8 ft) level	5104 mm (16 ft 8.9 in)	5557 mm (18 ft 2.8 in)	5708 mm (18 ft 8.7 in)
E. Max. vertical wall digging depth	3976 mm (13 ft 0.5 in)	4409 mm (14 ft 5.6 in)	4551 mm (14 ft 11.2 in)
F. Max. cutting height	9562 mm (31 ft 4.5 in)	9875 mm (32 ft 4.8 in)	9978 mm (32 ft 8.8 in)
G. Max. dumping height	6685 mm (21 ft 11.2 in)	6997 mm (22 ft 11.5 in)	7100 mm (23 ft 3.5 in)
H. Min. front slew radius	2713 mm (8 ft 10.8 in)	2818 mm (9 ft 3 in)	2848 mm (9 ft 4.1 in)



EW180E

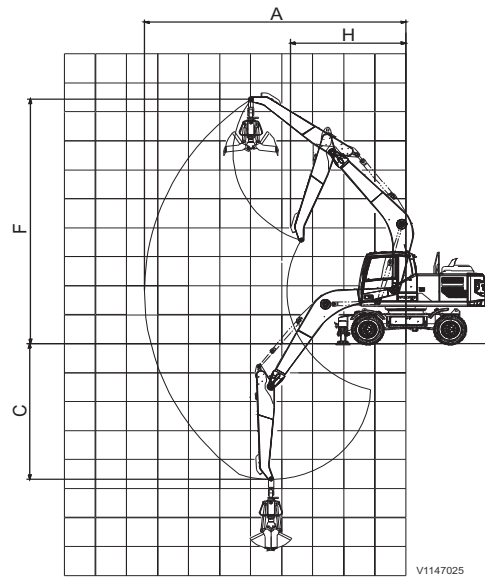
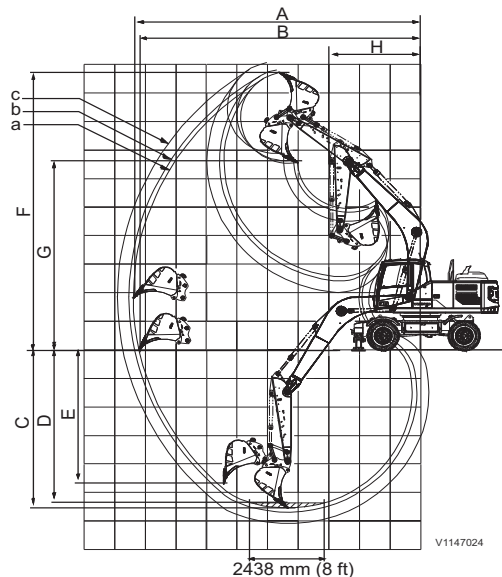

EW180E	5.2 m (17 ft 0.7 in)			
Monoblock boom				
Quick coupler	S1			-
Bucket	V4_GP			Clamshell
Dipper arm	a 2.45 m (8 ft 0.5 in)	b 2.6 m (8 ft 6.4 in)	c 3.0 m (9 ft 10.1 in)	3.2 m* (10 ft 6 in*)
A. Max. digging reach	9389 mm (30 ft 9.7 in)	9531 mm (31 ft 3.2 in)	9911 mm (32 ft 6.2 in)	8420 mm (27 ft 7.5 in)
B. Max. digging reach at ground level	9203 mm (30 ft 2.3 in)	9348 mm (30 ft 8 in)	9735 mm (31 ft 11.3 in)	-
C. Max. digging depth	5541 mm (18 ft 2.2 in)	5691 mm (18 ft 8.1 in)	6091 mm (19 ft 11.8 in)	4679 mm (15 ft 4.2 in)
D. Max. digging depth at 2438 mm (8 ft) level	5353 mm (17 ft 6.8 in)	5510 mm (18 ft 0.9 in)	5927 mm (19 ft 5.4 in)	-
E. Max. vertical wall digging depth	4703 mm (15 ft 5.2 in)	4853 mm (15 ft 11.1 in)	5233 mm (17 ft 2.0 in)	-
F. Max. cutting height	9721 mm (31 ft 10.7 in)	9818 mm (32 ft 2.5 in)	10068 mm (33 ft 0.4 in)	8441 mm (27 ft 8.3 in)
G. Max. dumping height	6532 mm (21 ft 5.2 in)	6626 mm (21 ft 8.9 in)	6877 mm (22 ft 6.8 in)	-
H. Min. front slew radius	2984 mm (9 ft 9.5 in)	3006 mm (9 ft 10.4 in)	3046 mm (9 ft 11.9 in)	3709 mm (12 ft 2 in)



Specifications
Working ranges

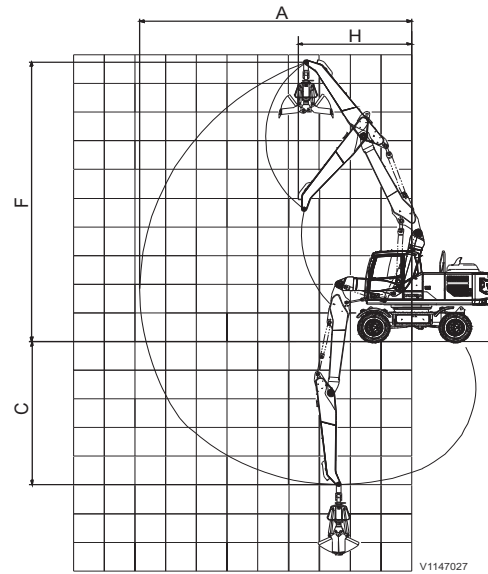
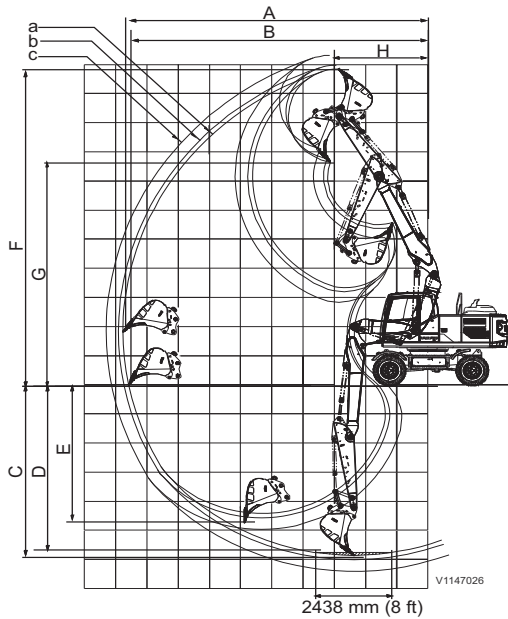

EW180E	5.5 m (18 ft 0.5 in)			
Two-piece boom				
Quick coupler	S1			-
Bucket	V4_GP			Clamshell
Dipper arm	a 2.45 m (8 ft 0.5 in)	b 2.6 m (8 ft 6.4 in)	c 3 m (9 ft 10.1 in)	3.2 m* (10 ft 6 in*)
A. Max. digging reach	9766 mm (32 ft 0.5 in)	9912 mm (32 ft 6.2 in)	10302 mm (33 ft 9.6 in)	8837 mm (28 ft 11.9 in)
B. Max. digging reach at ground level	9588 mm (31 ft 5.5 in)	9737 mm (31 ft 11.4 in)	10134 mm (33 ft 3 in)	-
C. Max. digging depth	5855 mm (19 ft 2.5 in)	6005 mm (19 ft 8.4 in)	6405 mm (21 ft 0.2 in)	4981 mm (16 ft 4.1 in)
D. Max. digging depth at 2438 mm (8 ft) level	5760 mm (18 ft 10.8 in)	5912 mm (19 ft 4.8 in)	6316 mm (20 ft 8.7 in)	-
E. Max. vertical wall digging depth	4738 mm (15 ft 6.5 in)	4900 mm (16 ft 0.9 in)	5276 mm (17 ft 3.7 in)	-
F. Max. cutting height	10846 mm (35 ft 7 in)	10973 mm (36 ft 0 in)	11312 mm (37 ft 1.4 in)	9749 mm (31 ft 11.8 in)
G. Max. dumping height	7647 mm (25 ft 1.1 in)	7777 mm (25 ft 6.2 in)	8115 mm (26 ft 7.5 in)	-
H. Min. front slew radius	3006 mm (9 ft 10.4 in)	3072 mm (10 ft 1 in)	3244 mm (10 ft 7.7 in)	3690 mm (12 ft 1.3 in)

* dipper arm for grab



Specifications
Recommended bucket sizes **365**

Recommended bucket sizes EW160E

For direct-fit buckets EW160E, 5.0 m (16 ft 4.9 in) Monoblock boom, Blade rear only														
Bucket type (Quick coupler)	Capacity		Cutting width		Weight		Recommended maximum material density (kg/m ³)							
							Standard Counterweight				Heavy Counterweight			
	Dipper arm													
	Liter	yd ³	mm	in	kg	lb	2 m (6 ft 6.7 in)	2.45 m (8 ft 0.5 in)	2.6 m (8 ft 6.4 in)	3.1 m (10 ft 2 in)	2 m (6 ft 6.7 in)	2.45 m (8 ft 0.5 in)	2.6 m (8 ft 6.4 in)	3.1 m (10 ft 2 in)
GP (without quick coupler)	300	0.39	450	17.72	354	781	1800	1800	1800	1800	1800	1800	1800	1800
	360	0.47	600	23.62	380	839	1800	1800	1800	1800	1800	1800	1800	1800
	580	0.76	900	35.43	469	1034	1800	1800	1800	1800	1800	1800	1800	1800
	700	0.92	1050	41.34	514	1133	1800	1800	1800	1700	1800	1800	1800	1800
	880	1.15	1250	49.21	598	1318	1800	1700	1500	1200	1800	1800	1700	1500
	960	1.26	1350	53.15	639	1409	1600	1500	1400	1100	1800	1600	1500	1400
	300	0.39	450	17.72	390	860	1800	1800	1800	1800	1800	1800	1800	1800
	360	0.47	600	23.62	417	919	1800	1800	1800	1800	1800	1800	1800	1800
	460	0.60	750	29.53	450	992	1800	1800	1800	1800	1800	1800	1800	1800
	580	0.76	900	35.43	505	1113	1800	1800	1800	1800	1800	1800	1800	1800
700	0.92	1050	41.34	550	1213	1800	1800	1800	1600	1800	1800	1800	1800	
840	1.10	1200	47.24	618	1362	1800	1800	1600	1300	1800	1800	1800	1600	
TD (without quick coupler)	550	0.72	1800	70.87	850	1874	1600	1600	1600	1600	1600	1600	1600	1600
	550	0.72	1800	70.87	770	1698	1600	1600	1600	1600	1600	1600	1600	1600
	620	0.81	2000	78.74	902	1989	1600	1600	1600	1300	1600	1600	1600	1600
FD (without quick coupler)	620	0.81	2000	78.74	813	1792	1600	1600	1600	1400	1600	1600	1600	1600
	890	1.16	1400	55.12	634	1398	1600	1600	1500	1200	1600	1600	1600	1500
970	1.27	1500	59.06	667	1470	1600	1500	1300	1000	1600	1600	1500	1300	
	300	0.39	450	17.72	354	781	1800	1800	1800	1800	1800	1800	1800	1800
GP (with universal quick coupler)	360	0.47	600	23.62	380	839	1800	1800	1800	1800	1800	1800	1800	1800
	580	0.76	900	35.43	469	1034	1800	1800	1800	1700	1800	1800	1800	1800
	700	0.92	1050	41.34	514	1133	1800	1800	1700	1300	1800	1800	1800	1700
	880	1.15	1250	49.21	598	1318	1500	1400	1200	900	1800	1500	1400	1200
	960	1.26	1350	53.15	639	1409	1400	1200	1100	800	1600	1400	1200	1100
	300	0.39	450	17.72	390	860	1800	1800	1800	1800	1800	1800	1800	1800
	360	0.47	600	23.62	417	919	1800	1800	1800	1800	1800	1800	1800	1800
	460	0.60	750	29.53	450	992	1800	1800	1800	1800	1800	1800	1800	1800
	580	0.76	900	35.43	505	1113	1800	1800	1800	1600	1800	1800	1800	1800
	700	0.92	1050	41.34	550	1213	1800	1800	1800	1300	1800	1800	1800	1600
840	1.10	1200	47.24	618	1362	1600	1400	1300	1000	1800	1600	1400	1300	
TD (with universal quick coupler)	550	0.72	1800	70.87	850	1874	1600	1600	1600	1100	1600	1600	1600	1600
	550	0.72	1800	70.87	770	1698	1600	1600	1600	1200	1600	1600	1600	1600
	620	0.81	2000	78.74	902	1989	1600	1500	1300	900	1600	1600	1500	1300
FD (with universal quick coupler)	620	0.81	2000	78.74	813	1792	1600	1600	1400	1000	1600	1600	1600	1400
	890	1.16	1400	55.12	634	1398	1500	1300	1200	900	1600	1500	1300	1200
970	1.27	1500	59.06	667	1470	1300	1200	1100	800	1600	1300	1200	1100	

For direct-fit buckets EW160E, 5.1 m (16 ft 8.8 in) Two-piece boom, Blade rear only														
Bucket type (Quick coupler)	Capacity		Cutting width		Weight		Recommended maximum material density (kg/m ³)							
							Standard Counterweight				Heavy Counterweight			
	Dipper arm													
	Liter	yd ³	mm	in	kg	lb	2 m (6 ft 6.7 in)	2.45 m (8 ft 0.5 in)	2.6 m (8 ft 6.4 in)	3.1 m (10 ft 2 in)	2 m (6 ft 6.7 in)	2.45 m (8 ft 0.5 in)	2.6 m (8 ft 6.4 in)	3.1 m (10 ft 2 in)
GP (without quick coupler)	300	0.39	450	17.72	354	781	1800	1800	1800	1800	1800	1800	1800	1800
	360	0.47	600	23.62	380	839	1800	1800	1800	1800	1800	1800	1800	1800
	580	0.76	900	35.43	469	1034	1800	1800	1800	1800	1800	1800	1800	1800
	700	0.92	1050	41.34	514	1133	1800	1800	1800	1700	1800	1800	1800	1800
	880	1.15	1250	49.21	598	1318	1800	1500	1400	1200	1800	1700	1700	1400
	960	1.26	1350	53.15	639	1409	1600	1400	1200	1100	1800	1500	1500	1200
	300	0.39	450	17.72	390	860	1800	1800	1800	1800	1800	1800	1800	1800
	360	0.47	600	23.62	417	919	1800	1800	1800	1800	1800	1800	1800	1800
	460	0.60	750	29.53	450	992	1800	1800	1800	1800	1800	1800	1800	1800
	580	0.76	900	35.43	505	1113	1800	1800	1800	1800	1800	1800	1800	1800
700	0.92	1050	41.34	550	1213	1800	1800	1800	1600	1800	1800	1800	1800	
840	1.10	1200	47.24	618	1362	1800	1600	1400	1300	1800	1800	1800	1400	
TD (without quick coupler)	550	0.72	1800	70.87	850	1874	1600	1600	1600	1600	1600	1600	1600	1600
	550	0.72	1800	70.87	770	1698	1600	1600	1600	1600	1600	1600	1600	1600
	620	0.81	2000	78.74	902	1989	1600	1600	1500	1300	1600	1600	1600	1500
620	0.81	2000	78.74	813	1792	1600	1600	1600	1400	1600	1600	1600	1600	



366 Specifications Recommended bucket sizes

**For direct-fit buckets
EW160E, 5.1 m (16 ft 8.8 in) Two-piece boom, Blade rear only**

Bucket type (Quick coupler)	Capacity		Cutting width		Weight		Recommended maximum material density (kg/m ³)							
							Standard Counterweight				Heavy Counterweight			
							Dipper arm							
	Liter	yd ³	mm	in	kg	lb	2 m (6 ft 6.7 in)	2.45 m (8 ft 0.5 in)	2.6 m (8 ft 6.4 in)	3.1 m (10 ft 2 in)	2 m (6 ft 6.7 in)	2.45 m (8 ft 0.5 in)	2.6 m (8 ft 6.4 in)	3.1 m (10 ft 2 in)
FD (without quick coupler)	890	1.16	1400	55.12	634	1398	1600	1500	1300	1200	1600	1600	1600	1300
	970	1.27	1500	59.06	667	1470	1600	1300	1200	1000	1600	1500	1500	1200
GP (with universal quick coupler)	300	0.39	450	17.72	354	781	1800	1800	1800	1800	1800	1800	1800	1800
	360	0.47	600	23.62	380	839	1800	1800	1800	1800	1800	1800	1800	1800
	580	0.76	900	35.43	469	1034	1800	1800	1800	1700	1800	1800	1800	1800
	700	0.92	1050	41.34	514	1133	1800	1700	1500	1300	1800	1800	1800	1500
	880	1.15	1250	49.21	598	1318	1500	1200	1100	900	1700	1400	1400	1100
	960	1.26	1350	53.15	639	1409	1400	1100	1000	800	1500	1200	1200	1000
	300	0.39	450	17.72	390	860	1800	1800	1800	1800	1800	1800	1800	1800
	360	0.47	600	23.62	417	919	1800	1800	1800	1800	1800	1800	1800	1800
	460	0.60	750	29.53	450	992	1800	1800	1800	1800	1800	1800	1800	1800
	580	0.76	900	35.43	505	1113	1800	1800	1800	1600	1800	1800	1800	1800
TD (with universal quick coupler)	700	0.92	1050	41.34	550	1213	1800	1600	1500	1300	1800	1800	1800	1500
	840	1.10	1200	47.24	618	1362	1600	1300	1100	1000	1800	1400	1400	1100
	550	0.72	1800	70.87	850	1874	1600	1600	1300	1100	1600	1600	1600	1300
	550	0.72	1800	70.87	770	1698	1600	1600	1500	1200	1600	1600	1600	1500
FD (with universal quick coupler)	620	0.81	2000	78.74	902	1989	1600	1300	1100	900	1600	1500	1500	1100
	620	0.81	2000	78.74	813	1792	1600	1400	1200	1000	1600	1600	1600	1200
FD (with universal quick coupler)	890	1.16	1400	55.12	634	1398	1500	1200	1000	900	1600	1300	1300	1000
	970	1.27	1500	59.06	667	1470	1300	1100	900	800	1500	1200	1200	900

**For quick coupler buckets
EW160E, 5.0 m (16 ft 4.9 in) Monoblock boom, Blade rear only**

Bucket type (Quick coupler)	Capacity		Cutting width		Weight		Recommended maximum material density (kg/m ³)							
							Standard Counterweight				Heavy Counterweight			
							Dipper arm							
	Liter	yd ³	mm	in	kg	lb	2 m (6 ft 6.7 in)	2.45 m (8 ft 0.5 in)	2.6 m (8 ft 6.4 in)	3.1 m (10 ft 2 in)	2 m (6 ft 6.7 in)	2.45 m (8 ft 0.5 in)	2.6 m (8 ft 6.4 in)	3.1 m (10 ft 2 in)
GP (S1)	420	0.55	600	23.62	508	1120	1800	1800	1800	1800	1800	1800	1800	1800
	560	0.73	800	31.50	583	1284	1800	1800	1800	1600	1800	1800	1800	1800
	660	0.86	900	35.43	623	1373	1800	1800	1700	1300	1800	1800	1800	1700
	800	1.05	1050	41.34	682	1503	1700	1500	1300	1000	1800	1700	1500	1300
	950	1.24	1200	47.24	760	1676	1300	1200	1000	800	1600	1300	1200	1000
	1100	1.44	1350	53.15	823	1814	1100	900	800	600	1300	1100	900	800
GP (S6)	300	0.39	450	17.72	336	742	1800	1800	1800	1800	1800	1800	1800	1800
	360	0.47	600	23.62	363	800	1800	1800	1800	1800	1800	1800	1800	1800
	580	0.76	900	35.43	451	995	1800	1800	1800	1800	1800	1800	1800	1800
	700	0.92	1050	41.34	496	1094	1800	1800	1800	1500	1800	1800	1800	1800
	880	1.15	1250	49.21	582	1284	1700	1600	1400	1100	1800	1700	1600	1400
	960	1.26	1350	53.15	623	1374	1500	1400	1200	1000	1800	1500	1400	1200
	300	0.39	450	17.72	368	811	1800	1800	1800	1800	1800	1800	1800	1800
	360	0.47	600	23.62	395	871	1800	1800	1800	1800	1800	1800	1800	1800
	460	0.60	750	29.53	428	944	1800	1800	1800	1800	1800	1800	1800	1800
	580	0.76	900	35.43	483	1065	1800	1800	1800	1800	1800	1800	1800	1800
GP (S60)	700	0.92	1050	41.34	528	1164	1800	1800	1800	1500	1800	1800	1800	1800
	840	1.10	1200	47.24	598	1318	1800	1600	1500	1100	1800	1800	1600	1500
	300	0.39	450	17.72	336	742	1800	1800	1800	1800	1800	1800	1800	1800
	360	0.47	600	23.62	363	800	1800	1800	1800	1800	1800	1800	1800	1800
	580	0.76	900	35.43	451	995	1800	1800	1800	1800	1800	1800	1800	1800
	700	0.92	1050	41.34	496	1094	1800	1800	1800	1500	1800	1800	1800	1800
	880	1.15	1250	49.21	582	1284	1700	1600	1400	1100	1800	1700	1600	1400
	960	1.26	1350	53.15	623	1374	1500	1400	1200	1000	1800	1500	1400	1200
	300	0.39	450	17.72	368	811	1800	1800	1800	1800	1800	1800	1800	1800
	360	0.47	600	23.62	395	871	1800	1800	1800	1800	1800	1800	1800	1800
GPX (S1)	460	0.60	750	29.53	428	944	1800	1800	1800	1800	1800	1800	1800	1800
	580	0.76	900	35.43	483	1065	1800	1800	1800	1800	1800	1800	1800	1800
	700	0.92	1050	41.34	528	1164	1800	1800	1800	1500	1800	1800	1800	1800
	840	1.10	1200	47.24	598	1318	1800	1600	1500	1100	1800	1800	1600	1500
GPX (S6)	800	1.05	965	37.99	700	1543	1600	1500	1300	1000	1800	1600	1500	1300
	910	1.19	1060	41.73	676	1490	1500	1300	1200	900	1800	1500	1300	1200
	1000	1.31	1145	45.08	789	1739	1200	1100	1000	700	1500	1200	1100	1000
GPX (S60)	750	0.98	1050	41.34	657	1448	1800	1700	1600	1200	1800	1800	1700	1600
	800	1.05	1100	43.31	689	1519	1700	1600	1400	1100	1800	1700	1600	1400
GPX (S60)	750	0.98	1050	41.34	657	1448	1800	1700	1600	1200	1800	1800	1700	1600
	800	1.05	1100	43.31	689	1519	1700	1600	1400	1100	1800	1700	1600	1400



Specifications
Recommended bucket sizes **367**

For quick coupler buckets
EW160E, 5.0 m (16 ft 4.9 in) Monoblock boom, Blade rear only

Bucket type (Quick coupler)	Capacity		Cutting width		Weight		Recommended maximum material density (kg/m ³)							
							Standard Counterweight				Heavy Counterweight			
	Liter	yd ³	mm	in	kg	lb	Dipper arm							
							2 m (6 ft 6.7 in)	2.45 m (8 ft 0.5 in)	2.6 m (8 ft 6.4 in)	3.1 m (10 ft 2 in)	2 m (6 ft 6.7 in)	2.45 m (8 ft 0.5 in)	2.6 m (8 ft 6.4 in)	3.1 m (10 ft 2 in)
TD (S1)	550	0.72	1800	70.87	893	1969	1600	1600	1600	1100	1600	1600	1600	1600
	550	0.72	2000	78.74	813	1792	1600	1600	1600	1200	1600	1600	1600	1600
	620	0.81	1800	70.87	946	2086	1600	1500	1300	900	1600	1600	1500	1300
	620	0.81	2000	78.74	856	1887	1600	1600	1500	1000	1600	1600	1600	1500
TD (S60)	550	0.72	1800	70.87	846	1865	1600	1600	1600	1300	1600	1600	1600	1600
	550	0.72	1800	70.87	766	1689	1600	1600	1600	1500	1600	1600	1600	1600
	620	0.81	2000	78.74	898	1980	1600	1600	1500	1100	1600	1600	1600	1500
	620	0.81	2000	78.74	808	1781	1600	1600	1600	1200	1600	1600	1600	1600
CAX (S6)	330	0.43	500	19.69	397	875	1800	1800	1800	1800	1800	1800	1800	1800
	540	0.71	700	27.56	488	1076	1800	1800	1800	1800	1800	1800	1800	1800
CAX (S60)	330	0.43	500	19.69	397	875	1800	1800	1800	1800	1800	1800	1800	1800
	540	0.71	700	27.56	488	1076	1800	1800	1800	1800	1800	1800	1800	1800
TGX (S1)	1060	1.39	1800	70.87	750	1653	1200	1100	900	700	1400	1200	1100	900
TGX (S6)	820	1.07	1600	62.99	839	1850	1500	1400	1200	900	1800	1500	1400	1200
TGX (S60)	820	1.07	1600	62.99	839	1850	1500	1400	1200	900	1800	1500	1400	1200

For quick coupler buckets
EW160E, 5.1 m (16 ft 8.8 in) Two-piece boom, Blade rear only

Bucket type (Quick coupler)	Capacity		Cutting width		Weight		Recommended maximum material density (kg/m ³)							
							Standard Counterweight				Heavy Counterweight			
	Liter	yd ³	mm	in	kg	lb	Dipper arm							
							2 m (6 ft 6.7 in)	2.45 m (8 ft 0.5 in)	2.6 m (8 ft 6.4 in)	3.1 m (10 ft 2 in)	2 m (6 ft 6.7 in)	2.45 m (8 ft 0.5 in)	2.6 m (8 ft 6.4 in)	3.1 m (10 ft 2 in)
GP (S1)	420	0.55	600	23.62	508	1120	1800	1800	1800	1800	1800	1800	1800	1800
	560	0.73	800	31.50	583	1284	1800	1800	1800	1600	1800	1800	1800	1800
	660	0.86	900	35.43	623	1373	1800	1700	1500	1300	1800	1800	1800	1500
	800	1.05	1050	41.34	682	1503	1700	1300	1200	1000	1800	1500	1500	1200
	950	1.24	1200	47.24	760	1676	1300	1000	900	800	1500	1200	1200	900
GP (S6)	1100	1.44	1350	53.15	823	1814	1100	800	700	600	1200	900	900	700
	300	0.39	450	17.72	336	742	1800	1800	1800	1800	1800	1800	1800	1800
	360	0.47	600	23.62	363	800	1800	1800	1800	1800	1800	1800	1800	1800
	580	0.76	900	35.43	451	995	1800	1800	1800	1800	1800	1800	1800	1800
	700	0.92	1050	41.34	496	1094	1800	1800	1700	1500	1800	1800	1800	1700
	880	1.15	1250	49.21	582	1284	1700	1400	1300	1100	1800	1600	1600	1300
	960	1.26	1350	53.15	623	1374	1500	1200	1100	1000	1700	1400	1400	1100
	300	0.39	450	17.72	368	811	1800	1800	1800	1800	1800	1800	1800	1800
	360	0.47	600	23.62	395	871	1800	1800	1800	1800	1800	1800	1800	1800
	460	0.60	750	29.53	428	944	1800	1800	1800	1800	1800	1800	1800	1800
	580	0.76	900	35.43	483	1065	1800	1800	1800	1800	1800	1800	1800	1800
	700	0.92	1050	41.34	528	1164	1800	1800	1700	1500	1800	1800	1800	1700
	840	1.10	1200	47.24	598	1318	1800	1500	1300	1100	1800	1600	1600	1300
GP (S60)	300	0.39	450	17.72	336	742	1800	1800	1800	1800	1800	1800	1800	1800
	360	0.47	600	23.62	363	800	1800	1800	1800	1800	1800	1800	1800	1800
	580	0.76	900	35.43	451	995	1800	1800	1800	1800	1800	1800	1800	1800
	700	0.92	1050	41.34	496	1094	1800	1800	1700	1500	1800	1800	1800	1700
	880	1.15	1250	49.21	582	1284	1700	1400	1300	1100	1800	1600	1600	1300
	960	1.26	1350	53.15	623	1374	1500	1200	1100	1000	1700	1400	1400	1100
	300	0.39	450	17.72	368	811	1800	1800	1800	1800	1800	1800	1800	1800
	360	0.47	600	23.62	395	871	1800	1800	1800	1800	1800	1800	1800	1800
	460	0.60	750	29.53	428	944	1800	1800	1800	1800	1800	1800	1800	1800
	580	0.76	900	35.43	483	1065	1800	1800	1800	1800	1800	1800	1800	1800
GPX (S1)	800	1.05	965	37.99	700	1543	1600	1300	1100	1000	1800	1500	1500	1100
	910	1.19	1060	41.73	676	1490	1500	1200	1000	900	1600	1300	1300	1000
	1000	1.31	1145	45.08	789	1739	1200	1000	800	700	1400	1100	1100	800
	750	0.98	1050	41.34	657	1448	1800	1600	1400	1200	1800	1700	1700	1400
GPX (S6)	800	1.05	1100	43.31	689	1519	1700	1400	1200	1100	1800	1600	1600	1200
	750	0.98	1050	41.34	657	1448	1800	1600	1400	1200	1800	1700	1700	1400
GPX (S60)	800	1.05	1100	43.31	689	1519	1700	1400	1200	1100	1800	1600	1600	1200
	550	0.72	1800	70.87	893	1969	1600	1600	1300	1100	1600	1600	1600	1300
	550	0.72	2000	78.74	813	1792	1600	1600	1500	1200	1600	1600	1600	1500
	620	0.81	1800	70.87	946	2086	1600	1300	1100	900	1600	1500	1500	1100
TD (S1)	620	0.81	2000	78.74	856	1887	1600	1500	1200	1000	1600	1600	1600	1200
	550	0.72	1800	70.87	846	1865	1600	1600	1600	1300	1600	1600	1600	1600
	550	0.72	1800	70.87	766	1689	1600	1600	1600	1500	1600	1600	1600	1600
	620	0.81	2000	78.74	898	1980	1600	1500	1300	1100	1600	1600	1600	1300
TD (S60)	620	0.81	2000	78.74	808	1781	1600	1600	1400	1200	1600	1600	1600	1400



Specifications 368 Recommended bucket sizes

For quick coupler buckets
EW160E, 5.1 m (16 ft 8.8 in) Two-piece boom, Blade rear only

Bucket type (Quick coupler)	Capacity		Cutting width		Weight		Recommended maximum material density (kg/m ³)							
							Standard Counterweight				Heavy Counterweight			
	Liter	yd ³	mm	in	kg	lb	Dipper arm							
							2 m (6 ft 6.7 in)	2.45 m (8 ft 0.5 in)	2.6 m (8 ft 6.4 in)	3.1 m (10 ft 2 in)	2 m (6 ft 6.7 in)	2.45 m (8 ft 0.5 in)	2.6 m (8 ft 6.4 in)	3.1 m (10 ft 2 in)
CAX (S6)	330	0.43	500	19.69	397	875	1800	1800	1800	1800	1800	1800	1800	1800
	540	0.71	700	27.56	488	1076	1800	1800	1800	1800	1800	1800	1800	1800
CAX (S60)	330	0.43	500	19.69	397	875	1800	1800	1800	1800	1800	1800	1800	1800
	540	0.71	700	27.56	488	1076	1800	1800	1800	1800	1800	1800	1800	1800
TGX (S1)	1060	1.39	1800	70.87	750	1653	1200	900	800	700	1300	1100	1100	800
TGX (S6)	820	1.07	1600	62.99	839	1850	1500	1200	1000	900	1700	1400	1400	1000
TGX (S60)	820	1.07	1600	62.99	839	1850	1500	1200	1000	900	1700	1400	1400	1000



Specifications
Recommended bucket sizes **369**

EW180E

For direct-fit buckets
EW180E, 5.2 m (17 ft 0.7 in) Monoblock boom, Blade rear only

Bucket type (Quick coupler)	Capacity		Cutting width		Weight		Recommended maximum material density (kg/m ³)		
	Liter	yd ³	mm	in	kg	lb	Dipper arm		
							2.45 m (8 ft 0.5 in)	2.6 m (8 ft 6.4 in)	3.0 m (9 ft 10.1 in)
GP (without quick coupler)	420	0.55	600	23.62	512	1129	1800	1800	1800
	560	0.73	800	31.50	587	1294	1800	1800	1800
	660	0.86	900	35.43	627	1382	1800	1800	1800
	800	1.05	1050	41.34	686	1512	1800	1800	1800
	950	1.24	1200	47.24	764	1685	1800	1700	1500
	1100	1.44	1350	53.15	839	1849	1500	1400	1200
	660	0.86	900	35.43	663	1462	1800	1800	1800
TD (without quick coupler)	800	1.05	1050	41.34	722	1592	1800	1800	1800
	550	0.72	1800	70.87	851	1876	1600	1600	1600
	550	0.72	1800	70.87	771	1700	1600	1600	1600
	620	0.81	2000	78.74	903	1991	1600	1600	1600
FD (without quick coupler)	620	0.81	2000	78.74	814	1795	1600	1600	1600
	970	1.27	1500	59.06	671	1479	1600	1600	1600
GP (with universal quick coupler)	1050	1.37	1600	62.99	704	1552	1600	1600	1400
	420	0.55	600	23.62	512	1129	1800	1800	1800
GP (with universal quick coupler)	560	0.73	800	31.50	587	1294	1800	1800	1800
	660	0.86	900	35.43	627	1382	1800	1800	1800
	800	1.05	1050	41.34	686	1512	1800	1800	1600
	950	1.24	1200	47.24	764	1685	1500	1400	1300
	1100	1.44	1350	53.15	839	1849	1200	1100	1000
	660	0.86	900	35.43	663	1462	1800	1800	1800
	800	1.05	1050	41.34	722	1592	1800	1700	1500
TD (with universal quick coupler)	550	0.72	1800	70.87	851	1876	1600	1600	1600
	550	0.72	1800	70.87	771	1700	1600	1600	1600
	620	0.81	2000	78.74	903	1991	1600	1600	1600
	620	0.81	2000	78.74	814	1795	1600	1600	1600
FD (with universal quick coupler)	970	1.27	1500	59.06	671	1479	1600	1500	1300
	1050	1.37	1600	62.99	704	1552	1400	1300	1200

For direct-fit buckets
EW180E, 5.5 m (18 ft 0.5 in) Two-piece boom, Blade rear only

Bucket type (Quick coupler)	Capacity		Cutting width		Weight		Recommended maximum material density (kg/m ³)		
	Liter	yd ³	mm	in	kg	lb	Dipper arm		
							2.45 m (8 ft 0.5 in)	2.6 m (8 ft 6.4 in)	3.0 m (9 ft 10.1 in)
GP (without quick coupler)	420	0.55	600	23.62	512	1129	1800	1800	1800
	560	0.73	800	31.50	587	1294	1800	1800	1800
	660	0.86	900	35.43	627	1382	1800	1800	1800
	800	1.05	1050	41.34	686	1512	1800	1800	1600
	950	1.24	1200	47.24	764	1685	1500	1500	1300
	1100	1.44	1350	53.15	839	1849	1200	1200	1000
	660	0.86	900	35.43	663	1462	1800	1800	1800
TD (without quick coupler)	800	1.05	1050	41.34	722	1592	1800	1800	1500
	550	0.72	1800	70.87	851	1876	1600	1600	1600
	550	0.72	1800	70.87	771	1700	1600	1600	1600
	620	0.81	2000	78.74	903	1991	1600	1600	1600
FD (without quick coupler)	620	0.81	2000	78.74	814	1795	1600	1600	1600
	970	1.27	1500	59.06	671	1479	1600	1600	1300
GP (with universal quick coupler)	1050	1.37	1600	62.99	704	1552	1400	1400	1200
	420	0.55	600	23.62	512	1129	1800	1800	1800
GP (with universal quick coupler)	560	0.73	800	31.50	587	1294	1800	1800	1800
	660	0.86	900	35.43	627	1382	1800	1800	1600
	800	1.05	1050	41.34	686	1512	1600	1600	1300
	950	1.24	1200	47.24	764	1685	1300	1300	1000
	1100	1.44	1350	53.15	839	1849	1000	1000	800
	660	0.86	900	35.43	663	1462	1800	1800	1600
	800	1.05	1050	41.34	722	1592	1500	1500	1200
TD (with universal quick coupler)	550	0.72	1800	70.87	851	1876	1600	1600	1600
	550	0.72	1800	70.87	771	1700	1600	1600	1600
	620	0.81	2000	78.74	903	1991	1600	1600	1300
	620	0.81	2000	78.74	814	1795	1600	1600	1400
FD (with universal quick coupler)	970	1.27	1500	59.06	671	1479	1300	1300	1000
	1050	1.37	1600	62.99	704	1552	1200	1200	900



Specifications

370 Recommended bucket sizes

For quick coupler buckets EW180E, 5.2 m (17 ft 0.7 in) Monoblock boom, Blade rear only									
Bucket type (Quick coupler)	Capacity		Cutting width		Weight		Recommended maximum material density (kg/m ³)		
	Liter	yd ³	mm	in	kg	lb	Dipper arm		
							2.45 m (8 ft 0.5 in)	2.6 m (8 ft 6.4 in)	3.0 m (9 ft 10.1 in)
GP (S1)	420	0.55	600	23.62	508	1120	1800	1800	1800
	560	0.73	800	31.50	583	1285	1800	1800	1800
	660	0.86	900	35.43	623	1373	1800	1800	1800
	800	1.05	1050	41.34	682	1503	1800	1800	1700
	950	1.24	1200	47.24	760	1676	1600	1500	1300
	1100	1.44	1350	53.15	823	1815	1300	1200	1100
	750	0.98	900	35.43	768	1693	1800	1800	1700
	920	1.20	1050	41.34	838	1847	1600	1400	1300
GP (S70)	560	0.73	800	31.50	613	1352	1800	1800	1800
	660	0.86	900	35.43	654	1441	1800	1800	1800
	800	1.05	1050	41.34	712	1571	1800	1800	1600
	950	1.24	1200	47.24	791	1744	1500	1400	1200
	1100	1.44	1350	53.15	866	1910	1200	1100	1000
GP (S60)	300	0.39	450	17.72	336	742	1800	1800	1800
	360	0.47	600	23.62	363	800	1800	1800	1800
	580	0.76	900	35.43	451	995	1800	1800	1800
	700	0.92	1050	41.34	496	1095	1800	1800	1800
	880	1.15	1250	49.21	582	1284	1800	1800	1700
	960	1.26	1350	53.15	623	1374	1800	1700	1500
GPX (S1)	800	1.05	965	37.99	700	1543	1800	1800	1700
	910	1.19	1060	41.73	676	1490	1800	1600	1500
	1000	1.31	1145	45.08	788	1737	1500	1400	1200
GPX (S70)	800	1.05	965	37.99	722	1592	1800	1700	1600
	910	1.19	1060	41.73	766	1689	1600	1500	1300
	1000	1.31	1145	45.08	817	1801	1400	1300	1200
GPX (S60)	800	1.05	955	37.60	674	1486	1800	1800	1800
	900	1.18	1050	41.43	717	1581	1800	1700	1500
	1000	1.31	1135	44.69	766	1689	1600	1500	1300
TD (S1)	550	0.72	1800	70.87	893	1969	1600	1600	1600
	550	0.72	1800	70.87	813	1792	1600	1600	1600
	620	0.81	2000	78.74	946	2086	1600	1600	1600
	620	0.81	2000	78.74	856	1887	1600	1600	1600
TD (S70)	550	0.72	1800	70.87	901	1986	1600	1600	1600
	550	0.72	1800	70.87	821	1810	1600	1600	1600
	620	0.81	2000	78.74	954	2103	1600	1600	1600
	620	0.81	2000	78.74	864	1905	1600	1600	1600
TD (S60)	550	0.72	1800	70.87	846	1865	1600	1600	1600
	550	0.72	1800	70.87	766	1689	1600	1600	1600
	620	0.81	2000	78.74	898	1980	1600	1600	1600
	620	0.81	2000	78.74	808	1781	1600	1600	1600
CAX (S1)	360	0.47	570	22.44	442	974	1800	1800	1800
	650	0.85	800	31.50	570	1257	1800	1800	1800
CAX (S70)	360	0.47	570	22.44	460	1014	1800	1800	1800
	650	0.85	800	31.50	586	1292	1800	1800	1800
CAX (S60)	330	0.43	500	16.69	397	875	1800	1800	1800
	540	0.71	700	27.56	488	1076	1800	1800	1800
TGX (S1)	1060	1.39	1800	70.87	750	1653	1400	1300	1200
TGX (S70)	1060	1.39	1800	70.87	768	1693	1400	1300	1100
TGX (S60)	960	1.26	1800	70.87	620	1367	1800	1700	1500

For quick coupler buckets EW180E, 5.5 m (17 ft 0.7 in) Two-piece boom, Blade rear only									
Bucket type (Quick coupler)	Capacity		Cutting width		Weight		Recommended maximum material density (kg/m ³)		
	Liter	yd ³	mm	in	kg	lb	Dipper arm		
							2.45 m (8 ft 0.5 in)	2.6 m (8 ft 6.4 in)	3.0 m (9 ft 10.1 in)
GP (S1)	420	0.55	600	23.62	508	1120	1800	1800	1800
	560	0.73	800	31.50	583	1285	1800	1800	1800
	660	0.86	900	35.43	623	1373	1800	1800	1700
	800	1.05	1050	41.34	682	1503	1700	1700	1300
	950	1.24	1200	47.24	760	1676	1300	1300	1000
	1100	1.44	1350	53.15	823	1815	1100	1100	800
	750	0.98	900	35.43	768	1693	1700	1700	1300
	920	1.20	1050	41.34	838	1847	1300	1300	1000
GP (S70)	560	0.73	800	31.50	613	1352	1800	1800	1800
	660	0.86	900	35.43	654	1441	1800	1800	1600
	800	1.05	1050	41.34	712	1571	1600	1600	1300
	950	1.24	1200	47.24	791	1744	1200	1200	1000
	1100	1.44	1350	53.15	866	1910	1000	1000	800



Specifications
Recommended bucket sizes **371**

For quick coupler buckets
EW180E, 5.5 m (17 ft 0.7 in) Two-piece boom, Blade rear only

Bucket type (Quick coupler)	Capacity		Cutting width		Weight		Recommended maximum material density (kg/m ³)		
	Liter	yd ³	mm	in	kg	lb	Dipper arm		
							2.45 m (8 ft 0.5 in)	2.6 m (8 ft 6.4 in)	3.0 m (9 ft 10.1 in)
GP (S60)	300	0.39	450	17.72	336	742	1800	1800	1800
	360	0.47	600	23.62	363	800	1800	1800	1800
	580	0.76	900	35.43	451	995	1800	1800	1800
	700	0.92	1050	41.34	496	1095	1800	1800	1800
	880	1.15	1250	49.21	582	1284	1700	1700	1400
	960	1.26	1350	53.15	623	1374	1500	1500	1300
GPX (S1)	800	1.05	965	37.99	700	1543	1700	1700	1300
	910	1.19	1060	41.73	676	1490	1500	1500	1200
	1000	1.31	1145	45.08	788	1737	1200	1200	1000
GPX (S70)	800	1.05	965	37.99	722	1592	1600	1600	1200
	910	1.19	1060	41.73	766	1689	1300	1300	1000
	1000	1.31	1145	45.08	817	1801	1200	1200	900
GPX (S60)	800	1.05	955	37.60	674	1486	1800	1800	1500
	900	1.18	1050	41.43	717	1581	1500	1500	1200
	1000	1.31	1135	44.69	766	1689	1300	1300	1100
TD (S1)	550	0.72	1800	70.87	893	1969	1600	1600	1600
	550	0.72	1800	70.87	813	1792	1600	1600	1600
	620	0.81	2000	78.74	946	2086	1600	1600	1300
	620	0.81	2000	78.74	856	1887	1600	1600	1500
TD (S70)	550	0.72	1800	70.87	901	1986	1600	1600	1500
	550	0.72	1800	70.87	821	1810	1600	1600	1600
	620	0.81	2000	78.74	954	2103	1600	1600	1200
	620	0.81	2000	78.74	864	1905	1600	1600	1400
TD (S60)	550	0.72	1800	70.87	846	1865	1600	1600	1600
	550	0.72	1800	70.87	766	1689	1600	1600	1600
	620	0.81	2000	78.74	898	1980	1600	1600	1300
	620	0.81	2000	78.74	808	1781	1600	1600	1500
CAX (S1)	360	0.47	570	22.44	442	974	1800	1800	1800
	650	0.85	800	31.50	570	1257	1800	1800	1800
CAX (S70)	360	0.47	570	22.44	460	1014	1800	1800	1800
	650	0.85	800	31.50	586	1292	1800	1800	1800
CAX (S60)	330	0.43	500	16.69	397	875	1800	1800	1800
	540	0.71	700	27.56	488	1076	1800	1800	1800
TGX (S1)	1060	1.39	1800	70.87	750	1653	1200	1200	900
TGX (S70)	1060	1.39	1800	70.87	768	1693	1100	1100	900
TGX (S60)	960	1.26	1800	70.87	620	1367	1500	1500	1300

Abbreviations:		
GP: General Purpose	FD: Fixed Ditch	TGX: Grading (Tiltrotator)
HD: Heavy Duty	GPX: General Purpose	HDX: Heavy Duty
TD: Tilttable Ditch	CAX: Cable Bucket	EDX: Extreme Duty

NOTE!
Bucket capacity based on ISO 7451, heaped material with a 1:1 angle of repose.

NOTE!
The recommendations are given as a guide only, based on typical operation conditions.

NOTE!
Contact your Volvo dealer for the proper match of buckets and attachments to suit the application.



372 Specifications
Digging forces

Digging forces

Digging forces
with direct mounted bucket

EW160E

Monoblock boom	5.0 m (16 ft 5 in)			
Two-piece boom	5.1 m (17 ft 0.7 in)			
Dipper arm	2.0 m (6 ft 7 in)	2.45 m (8 ft)	2.6 m (8 ft 6 in)	3.1 m (10 ft 2 in)
Bucket radius	1320 mm (4 ft 3.9 in)	1320 mm (4 ft 3.9 in)	1320 mm (4 ft 3.9 in)	1320 mm (4 ft 3.9 in)
Break-out force (SAE/ISO) with Power Boost	111.1 kN / 126.3 kN (24976 lbf / 28393 lbf)	111.1 kN / 126.3 kN (24976 lbf / 28393 lbf)	111.1 kN / 126.3 kN (24976 lbf / 28393 lbf)	111.1 kN / 126.3 kN (24976 lbf / 28393 lbf)
Tear-out force (SAE/ISO)	94.3 kN / 97.9 kN (21198 lbf / 22000 lbf)	82.9 kN / 85.6 kN (18627 lbf / 19244 lbf)	79.6 kN / 82.2 kN (17903 lbf / 18473 lbf)	70.5 kN / 72.5 kN (15851 lbf / 16295 lbf)
Angle of rotation, bucket	187.4°	187.4°	187.4°	187.4°

Monoblock offset boom	4.75 m (15 ft 7 in)	
Two-piece offset boom	5.2 m (17 ft 0.7 in)	
Dipper arm	2.0 m (6 ft 7 in)	2.45 m (8 ft)
Bucket radius	1274 mm (4 ft 2.2 in)	1274 mm (4 ft 2.2 in)
Break-out force (SAE/ISO) with Power Boost	94.8 kN / 108 kN (21312 lbf / 24279 lbf)	94.8 kN / 108 kN (21312 lbf / 24279 lbf)
Tear-out force (SAE/ISO)	72.6 kN / 75 kN (16321 lbf / 16861 lbf)	63.6 kN / 65.5 kN (14298 lbf / 14725 lbf)
Angle of rotation, bucket	177.4°	177.4°

EW180E

Monoblock boom	5.2 m (17 ft 0.7 in)		
Two-piece boom	5.5 m (18 ft 0.5 in)		
Dipper arm	2.45 m (8 ft)	2.6 m (8 ft 6 in)	3.0 m (9 ft 10.1 in)
Bucket radius	1440 mm (4 ft 8.7 in)	1440 mm (4 ft 8.7 in)	1440 mm (4 ft 8.7 in)
Break-out force (SAE/ISO) with Power Boost	114.7 kN / 132 kN (25786 lbf / 29675 lbf)	114.7 kN / 132 kN (25786 lbf / 29675 lbf)	114.7 kN / 132 kN (25786 lbf / 29675 lbf)
Tear-out force (SAE/ISO)	102.1 kN / 105.6 kN (22961 lbf / 23739 lbf)	98.2 kN / 101.4 kN (22085 lbf / 22804 lbf)	89.2 kN / 91.8 kN (20047 lbf / 20637 lbf)
Angle of rotation, bucket	182°	182°	182°

Lifting capacities

At the dipper arm end, without bucket.

Unit for weights: 1000 kg (2205 lb)

For lifting capacity including bucket, simply subtract actual weight of bucket for the values.

Unit for length: 1 m (3.3 ft)

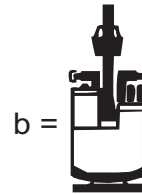
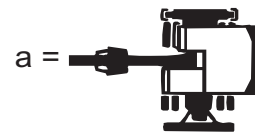
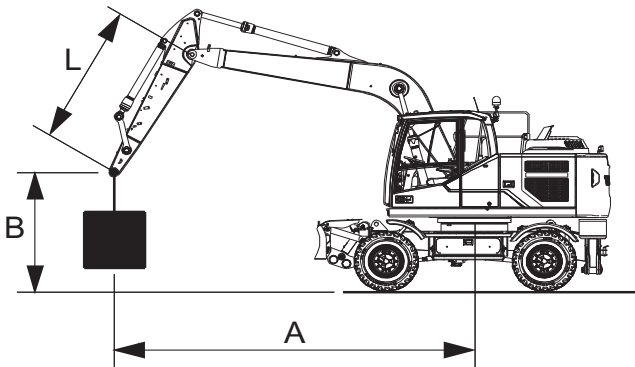

- A = Reach from machine centre
- B = Lifting hook related to ground level (m)
- L = Dipper arm length
- a = Superstructure across undercarriage
- b = Superstructure along undercarriage
- u = Support up
- d = Support down

Max. = Maximum reach / maximum high

*** = Grab arm

V1152572

Working pressure with power boost.

The values are in compliance with ISO standard 10 567. They do not exceed 87% of hydraulic lifting capacity or 75% of tipping load, with the machine on firm, level ground.

Load capacities marked with an asterisk (*) are limited by machine's hydraulic lifting capacity rather than tipping load.



388 Specifications
Lifting capacities

EW160E: 4.75 m Monoblock offset boom, 3200 kg Counterweight, 4 Outrigger (front and rear)

L	A B	1.5m						3m						4.5m						6m						7.5m						Max.	
		a		b		d		a		b		d		a		b		d		a		b		d		a		b		u	m		
		u	d	u	d	u	d	u	d	u	d	u	d	u	d	u	d	u	d	u	d	u	d	u	d	u	d	u	d				
7.5																																	
6																																	
4.5																																	
3																																	
1.5																																	
0																																	
-1.5																																	
-3																																	
-4.5																																	
7.5																																	
6																																	
4.5																																	
3																																	
1.5																																	
0																																	
-1.5																																	
-3																																	
-4.5																																	
7.5																																	
6																																	
4.5																																	
3																																	
1.5																																	
0																																	
-1.5																																	
-3																																	
-4.5																																	
7.5																																	
6																																	
4.5																																	
3																																	
1.5																																	
0																																	
-1.5																																	
-3																																	
-4.5																																	



Specifications
Lifting capacities 397

EW160E: 5.2 m Two-piece offset boom, 3600 kg Counterweight, Blade rear only

L	A B	1.5m				3m				4.5m				6m				7.5m				Max.					
		a		b		a		b		a		b		a		b		a		b		a		b		Max. m	
		u	d	u	d	u	d	u	d	u	d	u	d	u	d	u	d	u	d	u	d	u	d				
7.5																											
6																											
4.5																											
3																											
1.5																											
0																											
-1.5																											
-4.5																											
-4.5																											
7.5																											
6																											
4.5																											
3																											
1.5																											
0																											
-1.5																											
-3																											
-4.5																											
7.5																											
6																											
4.5																											
3																											
1.5																											
0																											
-1.5																											
-3																											
-4.5																											
7.5																											
6																											
4.5																											
3																											
1.5																											
0																											
-1.5																											
-3																											
-4.5																											



Specifications
406 Service history

Service history

Service 500 hours		Type of service <input type="checkbox"/> First 500 hours inspection <input type="checkbox"/> Service and maintenance	Signature and stamp
Date	Hours		

Service 1000 hours		Type of service <input type="checkbox"/> Service and maintenance	Signature and stamp
Date	Hours		

Service 1500 hours		Type of service <input type="checkbox"/> Service and maintenance	Signature and stamp
Date	Hours		

Service 2000 hours		Type of service <input type="checkbox"/> Service and maintenance	Signature and stamp
Date	Hours		

Service 2500 hours		Type of service <input type="checkbox"/> Service and maintenance	Signature and stamp
Date	Hours		

Service 3000 hours		Type of service <input type="checkbox"/> Service and maintenance	Signature and stamp
Date	Hours		

Service 3500 hours		Type of service <input type="checkbox"/> Service and maintenance	Signature and stamp
Date	Hours		

Service 4000 hours		Type of service <input type="checkbox"/> Service and maintenance	Signature and stamp
Date	Hours		

Service 4500 hours		Type of service <input type="checkbox"/> Service and maintenance	Signature and stamp
Date	Hours		

Service 5000 hours		Type of service <input type="checkbox"/> Service and maintenance	Signature and stamp
Date	Hours		



Specifications
Service history **407**

Service 5500 hours		Type of service <input type="checkbox"/> Service and maintenance	Signature and stamp
Date	Hours		
Service 6000 hours		Type of service <input type="checkbox"/> Service and maintenance	Signature and stamp
Date	Hours		
Service 6500 hours		Type of service <input type="checkbox"/> Service and maintenance	Signature and stamp
Date	Hours		
Service 7000 hours		Type of service <input type="checkbox"/> Service and maintenance	Signature and stamp
Date	Hours		
Service 7500 hours		Type of service <input type="checkbox"/> Service and maintenance	Signature and stamp
Date	Hours		
Service 8000 hours		Type of service <input type="checkbox"/> Service and maintenance	Signature and stamp
Date	Hours		
Service 8500 hours		Type of service <input type="checkbox"/> Service and maintenance	Signature and stamp
Date	Hours		
Service 9000 hours		Type of service <input type="checkbox"/> Service and maintenance	Signature and stamp
Date	Hours		
Service 9500 hours		Type of service <input type="checkbox"/> Service and maintenance	Signature and stamp
Date	Hours		
Service 10000 hours		Type of service <input type="checkbox"/> Service and maintenance	Signature and stamp
Date	Hours		



A series of horizontal dotted lines for writing, consisting of 20 lines spaced evenly down the page.



Alphabetical index

A

Accidents.....	147
Accumulator, emergency operation.....	317
Accumulator, handling.....	317
Accumulator, pressure releasing.....	317
AdBlue®/DEF.....	336
AdBlue®/DEF information.....	7
AdBlue®/DEF tank, draining.....	304
AdBlue®/DEF, filling.....	303
Alarm texts.....	48
Alternative fuels.....	332
Arrival Inspection.....	264
Attachment quick coupler.....	210, 214, 215, 217, 298
Attachments.....	207
Attachments, alternative lowering.....	183
Attachments, connecting and disconnecting.....	210
Audio system.....	126
Automatic lubrication system.....	318
Axles, checking oil level.....	292

B

Batteries.....	261
Batteries, charging.....	306
Battery disconnect switch.....	252
Battery electrolyte level, check.....	295
Before service, read.....	249
Boom Suspension System (BSS).....	197
Brake system.....	8
Braking.....	163
Bucket cylinder grapple lines.....	225
Bucket teeth, replacing.....	314
Buckets.....	222

C

Cab.....	9, 104, 348
CAB auxiliary heater, description.....	132
Cab door hinges, greasing.....	295
Cab main filter, cleaning.....	297
Cab prefilter, cleaning and replacing.....	294
CareTrack.....	10
CareTrack with anti-theft.....	70
CE-marking, EMC-directive.....	13
Changing bucket.....	223
Cleaning engine compartment.....	310
Cleaning machine.....	309
Climate control system.....	119
Comfort Drive Control (CDC).....	161
Communication equipment, installation.....	16
Control levers, description.....	94
Control lockout system.....	110
Control types for X1 and X3 operation.....	79
Controls.....	91
Coolant.....	301, 331
Coolant level, checking.....	288

D

Delivery Inspection.....	264
Delivery Instructions.....	265
Deluxe seat (optional equipment).....	116
Demolition work.....	205
Digging forces.....	372
Dimensions.....	353
Display unit.....	47
Door.....	122

E

Eco driving.....	192
Electric digging brake.....	164
Electrical distribution box.....	252
Electrical system.....	8, 340
Emergency exit.....	125
Emission compliance.....	171
Engine.....	7, 339

Engine air cleaner.....	311
Engine air cleaner primary filter, cleaning and replacing.....	311
Engine air cleaner secondary filter, replacing.....	313
Engine block heater.....	154
Engine oil level, checking.....	287
Entering, leaving and climbing the machine.....	255
Environmental requirements.....	7
Equipment.....	9
Equipment towing.....	234
EU conformity certificate.....	15
Excavator unit, greasing.....	274, 278
Exhaust aftertreatment system.....	8, 165
Exhaust aftertreatment system, alarms requiring special actions.....	172

F

Filter change, intervals.....	338
Fire extinguisher, location.....	125
Fire prevention.....	257
Fuel.....	332
Fuel system.....	332
Fuel system, bleeding.....	305
Fuel tank, draining.....	305
Fuel, filling.....	302

G

Grab bucket.....	223
------------------	-----

H

Hammer.....	228
Hammer/shear.....	228
Hand-arm vibrations.....	349
Handling hazardous materials.....	259
Handling line, tubes and hoses.....	263
Headlights, adjusting.....	307
High voltage overhead power line.....	199
Hydraulic oil.....	254
Hydraulic oil level, checking.....	276
Hydraulic system.....	9, 253, 350
Hydraulic system, releasing pressure.....	221, 316
Hydraulic system, warming up.....	157

I

Identification numbers.....	6
Information and warning decals.....	19
Instrument panel, front.....	40
Instrument panel, left.....	34
Instrument panel, rear.....	90
Instrument panel, right.....	80
Intended use.....	7
Intercooler, radiator, hydraulic oil cooler, cleaning.....	298

L

Leakage, checking.....	274
Lifting capacities.....	373
Lifting machine.....	190
Lifting objects.....	230
Loading on to a vehicle.....	196
Logged machine data.....	10
Lubrication.....	268
Lubrication and service chart.....	264, 268, 269

M

Machine view.....	12
Machine weights.....	352
Main menu.....	50
Maintenance service, every 10 hours.....	273
Maintenance service, every 100 hours.....	283
Maintenance service, every 1000 hours.....	300
Maintenance service, every 2000 hours.....	301
Maintenance service, every 250 hours.....	287
Maintenance service, every 50 hours.....	275
Maintenance service, every 500 hours.....	295
Maintenance service, when required.....	302
Maintenance under special environmental conditions.....	326
Measurements before transporting machine.....	186
Measures before operating.....	152
Mode selection.....	158



Alphabetical index

410

Modifications.....	9	Travelling on public roads.....	149
Mono-block offset boom.....	227	Travelling speed.....	158
N		Turbocharger.....	156
Noise and vibrations.....	349	Two-piece offset boom.....	227
O		Tying down machine.....	186
Offset boom.....	227	Tyre sizes and pressures.....	344, 345
Oil and fluid change, intervals.....	338	Tyres, wear and air pressure, checking.....	275
Operating.....	158	U	
Operating on public roads.....	148	Undercarriage, greasing.....	283, 284
Operator comfort.....	111	Underground cables and pipes.....	201
Operator obligations.....	146	USA federal clean air act.....	29
Operator safety.....	147	V	
Operator seat.....	112	Visibility.....	140
Operator's manual, storage.....	125	Vision system.....	130
Overload warning.....	233, 300	W	
P		Washer reservoir.....	274
Paint finish maintenance.....	309	Water separator, draining.....	304
Parking.....	177	Welding.....	307
Parking brake.....	163	Wheel nuts, checking tightening.....	300
Parking brake, mechanical release.....	181	Wheel nuts, tightening torque.....	347
Pivot axle lock cylinder, manual release for towing.....	182	Wheels.....	344
Pivot axle locking.....	151	Whole-body vibrations.....	193, 349
Pressure release.....	221	Windows.....	121
Product plates.....	18	Working in cold weather.....	203
R		Working in water and on boggy ground.....	202
Rain shield.....	122	Working on slopes.....	202
Recommended bucket sizes.....	365	Working ranges.....	359
Recommended intervals for critical parts.....	325	Working where there is risk of landslip.....	203
Recommended lubricants.....	327	Working with buckets.....	222
Refrigerant.....	262, 348	Working within dangerous areas.....	199
Regeneration.....	165	X	
Relays and fuses.....	341	X1 control, description.....	99
Remote greasing nipples.....	274, 281	X3 control, description.....	98
Remote welcome lights.....	111		
Retrieving and towing.....	179		
Reversible fan.....	206		
Roof.....	123		
Rules for digging.....	195		
Running-in instructions.....	140		
S			
Safety components.....	17		
Safety rules when operating.....	146		
Seat belt.....	118		
Service capacities and change intervals.....	338		
Service history.....	264, 406		
Service points.....	266		
Service position.....	247		
Service Programme.....	265		
Setups.....	58		
Signalling diagram.....	243		
Starting engine.....	153		
Starting engine in cold weather.....	154		
Starting with booster batteries.....	155		
Steering.....	160		
Steering system.....	8		
Stopping.....	176		
Storage compartment.....	124		
Subscreens.....	50		
Sun shade.....	122		
Swing drive unit.....	10		
Swing drive unit, checking oil level.....	291		
Symbol key.....	268		
T			
Test-run and check.....	273		
Tiltrotator control system, description.....	102, 208		
Toggle lever for brake lock (digging brake).....	164		
Tool kit.....	11		
Touch-up painting.....	309		
Trailer towing solution (TTS).....	234		
Transporting machine.....	186		
Travel gearbox oil level, checking.....	292		
Travelling a short distance.....	157		



A series of horizontal dotted lines for writing, consisting of 20 lines.



Alphabetical index

412
